

elcometer®  
inspection equipment



2009

## Why choose Elcometer?

For more than sixty years Elcometer has been a world leader in the design, manufacture and supply of inspection equipment to the coatings industry.

Ever since the first Elcometer gauge was manufactured in 1947, our philosophy has been to provide 'best in class' design, quality and service at a competitive price. By concentrating on these core values, Elcometer has grown into a global network with representation in over 70 countries.

With a range of products specifically developed to meet the needs of the coatings industry, Elcometer is well positioned to provide you with the solution to your inspection requirements - whatever and wherever they might be.

## How to use this catalogue

Elcometer's product range has been separated into 20 distinct categories which are in regular use within the coatings industry.

These product categories featured within the catalogue follow the coating process - from coating development to post application inspection.

For more information please contact Elcometer.

## Fit for Purpose - Standards Explained

All Elcometer products are designed to comply with National and International Standards. We have a team of experts working with Standards bodies around the world, ensuring we have products fit for purpose, exceeding the demands of our customers.

In this catalogue, we have identified the latest National and International Standards - those in Orange are current and those in Grey have been superseded but are still recognised in some industries.

We continuously review our products against current and new Standards and for the most up to date list, visit our online catalogue which provides the latest information on all new, current and superseded Standards which our products can be used in accordance with.

## Service and Support

Elcometer has over 150 Distributors around the world, all comprehensively trained in our products, providing a full after sales service and support within your region. With the widest range of own manufactured products, Elcometer can provide a complete solution to all your inspection requirements.

## Quality is part of the Elcometer culture

Elcometer's commitment to quality is reflected in our ISO 9000 Quality and ISO 14001 Environmental certifications.

It is the Company philosophy to integrate quality into all aspects of the product - whether it be the initial product design or in our commitment to our customers.

Elcometer is committed to reducing its impact on the environment, both in product manufacture, packaging, catalogue production and waste management. All our products are lead and mercury free and, where required, CE and RoHS compliant.



## Product Innovation

Elcometer continues to be a leader in product innovation for the Inspection Industries in both hardware and software design with a team of specialists dedicated to product development. We are committed to continuously push the boundaries through our new product development programmes.

## Certification

Elcometer's products are designed and manufactured to the highest levels of quality ensuring that we can provide relevant certification where necessary.

To meet the various inspection requirements we offer the following certification, dependent on the product:

- C** Certificate of Calibration: issued for Fixed Calibration equipment and shows readings and traceability
- A** Accredited Certificate: can be issued for Fixed Calibration Equipment and a full UKAS traceable certificate is issued from an independent Calibration Laboratory
- T** Certificate of Test - for variable calibration equipment and supplied with readings. A Certificate of Inspection states the instrument is tested in accordance with our procedures.

## Training

Elcometer offers first class training on all its products to all our customers either at your facility or at our state of the art training facility in Manchester, England. For more information please contact Elcometer.

# Product Index



Product Code	Page	Product Code	Page	Product Code	Page	Product Code	Page
Elcometer 101	205	Elcometer 213	163 - 164	Elcometer 2080	68	Elcometer 3580	46
Elcometer 106	220	Elcometer 214	165 - 166	Elcometer 2200	20	Elcometer 3600	47
Elcometer 107	217	Elcometer 215	168 - 172	Elcometer 2210	12	Elcometer 3700	48
Elcometer 108	219	Elcometer 223	141	Elcometer 2215	14	Elcometer 3800	50
Elcometer 109	221	Elcometer 224	137	Elcometer 2280	28	Elcometer 3805	50
Elcometer 110	226	Elcometer 236	236 - 238	Elcometer 2290	28	Elcometer 4260	40
Elcometer 112	179	Elcometer 260	230	Elcometer 2300	21 - 25	Elcometer 4270	40
Elcometer 113	161	Elcometer 266	231 - 235	Elcometer 2310	13	Elcometer 4280	41
Elcometer 114	160	Elcometer 270	228 - 229	Elcometer 2350	16	Elcometer 4290	41
Elcometer 115	178	Elcometer 311	186	Elcometer 2351	16	Elcometer 4340	52 - 54
Elcometer 116	160	Elcometer 319	156 - 159	Elcometer 2352	16	Elcometer 4360	38 - 39
Elcometer 118/2	173	Elcometer 355	202 - 204	Elcometer 2353	15	Elcometer 4361	38 - 39
Elcometer 119	144	Elcometer 400	111	Elcometer 2354	15	Elcometer 4695	55 - 64
Elcometer 121	213	Elcometer 406	108	Elcometer 2400	17	Elcometer 4800	51
Elcometer 122	136	Elcometer 407	109	Elcometer 2410	18	Elcometer 4900	51
Elcometer 123	141	Elcometer 415	187	Elcometer 2434	10	Elcometer 5100	68
Elcometer 124	136	Elcometer 456	188 - 199	Elcometer 2435	10	Elcometer 5135	77 - 80
Elcometer 125	134	Elcometer 501	84	Elcometer 2436	11	Elcometer 5155	77 - 80
Elcometer 126	214	Elcometer 550	184	Elcometer 2437	11	Elcometer 5300	67
Elcometer 127	134	Elcometer 900	245	Elcometer 3000	88	Elcometer 5500	66
Elcometer 128	240	Elcometer 990	207	Elcometer 3025	89	Elcometer 5750	76
Elcometer 129	135	Elcometer 995	210	Elcometer 3030	90	Elcometer 6012	112
Elcometer 130	151	Elcometer 1500	100	Elcometer 3034	90	Elcometer 6014	113 - 114
Elcometer 131	242	Elcometer 1506	99	Elcometer 3040	90	Elcometer 6090	124
Elcometer 132	241	Elcometer 1510	98	Elcometer 3080	86	Elcometer 6210	115
Elcometer 133	135	Elcometer 1535	91 - 92	Elcometer 3086	85	Elcometer 6300	116 - 117
Elcometer 134	147 - 147, 152	Elcometer 1537	96	Elcometer 3092	87	Elcometer 6700	167
Elcometer 135	150	Elcometer 1538	96	Elcometer 3095	93	Elcometer 6075/1	118 - 119
Elcometer 137	244	Elcometer 1540	216	Elcometer 3101	95	Elcometer 6075/2	120 - 121
Elcometer 138	148 - 149	Elcometer 1542	218	Elcometer 3120	93 - 94	Elcometer 6075/3	122 - 123
Elcometer 138/2	153	Elcometer 1615	102 - 106	Elcometer 3230	183	Elcometer 6910	34 - 36
Elcometer 141	212	Elcometer 1620	101	Elcometer 3233	180	Elcometer 7060	142 - 143
Elcometer 142	146	Elcometer 1700	82	Elcometer 3236	179	Elcometer 7210	244
Elcometer 144	241	Elcometer 1720	70 - 75	Elcometer 3238	178	Elcometer 7220	245
Elcometer 154	180	Elcometer 1730	81	Elcometer 3240	214	Elcometer 7300	17
Elcometer 155	183	Elcometer 1800	30	Elcometer 3505	49	Elcometer 7400	174 - 175
Elcometer 157	205	Elcometer 1910	222	Elcometer 3508	49	Elcometer 7410	176
Elcometer 195	211	Elcometer 1940	223 - 224	Elcometer 3520	42	Elcometer 7420	176
Elcometer 204	128	Elcometer 1941	223 - 224	Elcometer 3525	43	Elcometer 7951	7
Elcometer 205	129	Elcometer 2000	6	Elcometer 3530	43	Elcometer 8720	31
Elcometer 206	129	Elcometer 2020	2	Elcometer 3540	44	Elcometer 8721	32
Elcometer 207	126 - 127	Elcometer 2041	2	Elcometer 3545	45		
Elcometer 208	130	Elcometer 2050	3	Elcometer 3550	44		
Elcometer 211	206	Elcometer 2060	5	Elcometer 3560	49		
Elcometer 212	162	Elcometer 2070	4	Elcometer 3570	45		

## Dispersion

From the development of coatings and inks in the laboratory to testing during the production process, quick and precise measurement of the particle size of the material - be it pigments or other similar materials - is one of the essential measurement techniques required for reliable and repeatable formulations.

Elcometer's stringent manufacturing standards ensure that the highest level of precision and quality is maintained for all its gauges in order to comply with the requirements of the industries where the grinding process is involved, particularly in the fields of wet paints and powder, varnishes, printing inks and cosmetics.

### ▪ **Fineness of Grind Gauges:**

The comprehensive range of Elcometer fineness of grind gauges consists of stainless steel blocks with a precision ground scraper. Each block has either one or two channels, precision ground in a uniformly increasing depth from zero at one end to a specified depth at the other, identified by the scale on the gauge.

### ▪ **Groove Depth Checker:**

The accuracy of fineness of grind gauges may be impaired after many uses. The digital Elcometer 2060 is ideal for providing an accurate method to check that the fineness of grind gauge is still within specification.

### ▪ **Muller Laboratory Grinder:**

Designed to grind and disperse small amounts of raw materials such as pigments for paint and varnish, the Elcometer 2000 enables optimum and reproducible results to be obtained in the laboratory. Ideal for preparing small samples for use in quality control of pigments, the Muller Grinder is also ideal for testing mass colour and tinting strength.

### ▪ **Paint Mixer:**

The Paint Mixer is an effective device for mixing and blending pigments and additives in a coating. With a maximum 5 litre (1.3 US gallon) capacity, it has been specifically designed to fit under most dispensing machines.



## Elcometer 2020 & 2041 Fineness of Grind

The Elcometer 2020 & Elcometer 2041 Fineness of Grind Gauges are instruments used to determine the particle size and fineness of grind of many materials including paints, pigments, inks, coatings, chocolates and other similar products.

These two channel gauges, together with the scrapers, are made of hardened stainless steel and have two grooves with a graded slope (dependent on the model chosen). Graduated in microns, mils, NS (Hegman) or PCU (North), the gauges have a tolerance of  $\pm 2\mu\text{m}$  (0.08mil). The groove width for all models is 12mm (0.47") with a groove length of 127mm (5.0").



**Elcometer 2041:** The basic gauge has lateral graduations engraved on the side of the gauge in mils or microns.

**Elcometer 2020:** The standard gauge shows graduations in microns or mils, NS and PCU which are all engraved on the top of the gauge.

### Technical Specification

certificate available

Part Number	Model	Range		Graduation			
		Metric	Imperial	Hegman (NS)	North (PCU)	$\mu\text{m}$	mils
K0002041M001	Elcometer 2041/1	-	-	-	-	1	-
K0002041M002	Elcometer 2041/2	K0US2041M002	K0US2041M002	-	-	2.5	0.1
K0002041M003	Elcometer 2041/3	K0US2041M003	K0US2041M003	-	-	5	0.2
K0002041M004	Elcometer 2041/4	K0US2041M004	K0US2041M004	-	-	10	0.5
K0002020M003	Elcometer 2020/3	-	-	8 - 7	10 - 9	1	-
K0002020M004	Elcometer 2020/4	K0US2020M004	K0US2020M004	8 - 6	10 - 8	2.5	0.1
K0002020M001	Elcometer 2020/1	K0US2020M001	K0US2020M001	8 - 4	10 - 5	5	0.2
K0002020M002	Elcometer 2020/2	K0US2020M002	K0US2020M002	8 - 0	10 - 0	10	0.5
Dimensions	180 x 40 x 12mm (7.1 x 1.6 x 0.5")						
Weight	1.36kg (3lb)						
Packing List	Elcometer 2020 or Elcometer 2041 Fineness of Grind Gauge, scraper, plastic case and operating instructions						

Can be used in accordance with: (see Standards Explained inside Front Cover)

ASTM D 1210, AS/NZS 1580.204.1, DIN 53203, EN 21524, FTMS 141 4411.1, ISO 1524

### Accessories

KT002020N001	Replacement Scraper for Elcometer 2020
KT002030N001	Replacement Scraper for Elcometer 2041

## Elcometer 2050 High Precision Grindometer

This precision instrument is used to determine particle size and fineness of grind for many materials including paints, pigments, inks, coatings, chocolates and other similar products.

The gauge and its scraper are made of hardened stainless steel and are graduated in microns on the top to an accuracy of  $\pm 1\mu\text{m}$  (0.04mil). The groove width is 12mm (0.47") and the groove length is 200mm (7.87").

The high precision Grindometer has a single groove.



### Technical Specification

**C** certificate available

Part Number		Model	Range		Graduation	
Metric	Imperial		$\mu\text{m}$	mils	$\mu\text{m}$	mils
<a href="#">K0002050M001</a>	<a href="#">K0US2050M001</a>	Elcometer 2050/1	0 - 25	0 - 1	1	0.05
<a href="#">K0002050M002</a>	<a href="#">K0US2050M002</a>	Elcometer 2050/2	0 - 50	0 - 2	2	0.1
<a href="#">K0002050M005</a>	<a href="#">K0US2050M005</a>	Elcometer 2050/5	0 - 100	0 - 4	5	0.2
<a href="#">K0002050M008</a>	<a href="#">K0US2050M008</a>	Elcometer 2050/8	0 - 250	0 - 10	12.5	0.5
Tolerance	$\pm 1\mu\text{m}$ (0.04mil)					
Dimensions	250 x 40 x 15mm (9.8 x 1.6 x 0.6")					
Weight	1.45kg (3.2lb)					
Packing List	Elcometer 2050 High Precision Grindometer, scraper, plastic case and operating instructions					
<i>Can be used in accordance with: (see Standards Explained inside Front Cover)</i>						
<a href="#">ASTM D 1210</a> , <a href="#">AS/NZS 1580.204.1</a> , <a href="#">DIN 53203</a> , <a href="#">EN 21524</a> , <a href="#">FTMS 141 4411.1</a> , <a href="#">ISO 1524</a>						

### Accessories

[KT002030N001](#) Replacement Scraper for Elcometer 2050

## Elcometer 2070 NPIRI Fineness of Grind Gauge

This precision instrument is used to determine particle size and the fineness of grind of particles in printing inks.

The NPIRI gauge and its scraper are made of hardened stainless steel and the gauge has two grooves with a gentle slope.

The groove width is 25mm (0.98") and the groove length is 165mm (6.5"). The NPIRI scale is displayed alongside the microns scale.



### Technical Specification

certificate available

Part Number	Model	Range		Graduation		
		Metric	Imperial	Metric	Imperial	
<b>K0002070M001</b>	<b>K0US2070M001</b>	Elcometer 2070	0 - 25	0 - 1	2.5µm / 1 NPIRI	0.1mil / 1 NPIRI
Dimensions	220 x 80 x 12mm (8.6 x 3.1 x 0.5")					
Weight	2.2kg (4.8lb)					
Packing List	Elcometer 2070 NPIRI Fineness of Grind Gauge, scraper, plastic case and operating instructions					
<i>Can be used in accordance with: (see Standards Explained inside Front Cover)</i>						
<b>ASTM D 1316</b>						

### Accessories

<b>KT002070N001</b>	Replacement Scraper for Elcometer 2070
---------------------	--

### How to use a Fineness of Grind Gauge

The material is placed on the deepest part of the groove and, using the scraper provided, drawn up the slope - the particle size is indicated where the material stops.

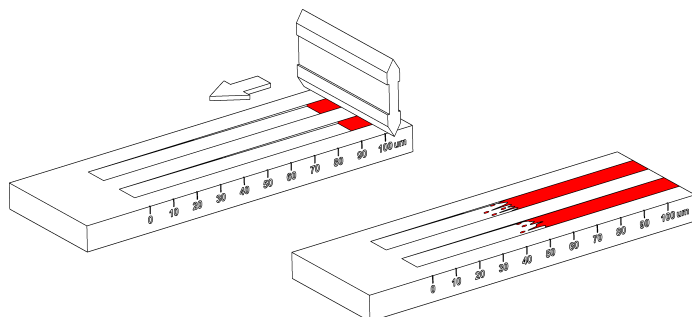



## Elcometer 2060 ISO Groove Depth Checker

The accuracy of fineness of grind gauges may be impaired after much use. The ISO Standard recommends the depth is checked regularly.

The Elcometer 2060 is a digital comparator with a tapering point, fitted on to a rule with a central V-shaped opening with a contact edge bevelled to an angle of 60° with thermal insulation on its upper surfaces.

The instrument is reset to zero beforehand on a reference surface. Positioned perpendicular to the groove, it provides an accurate measurement of the depth of the groove at the point being checked. Readings are in microns.



### Technical Specification

**CA** certificate available

Part Number	Description
<b>K0002060M001</b>	Elcometer 2060 ISO Groove Checker for Fineness of Grind Gauges
Range	0 to 6.48mm (0 to 0.26")
Resolution	1µm (0.04mil)
Accuracy	3µm (0.12mil)
Measuring Edge	60mm (2.36")
Battery	1.5 V, SR44 button cell
Dimensions	119 x 60 x 40mm (4.7 x 2.4 x 1.6")
Weight	377g (0.8lb)
Packing List	Elcometer 2060 ISO Groove Depth Checker, glass zero plate, storage case, calibration certificate and operating instructions

### Accessories

<b>KT002060P004</b>	RS232 Data Cable
---------------------	------------------

Customers who have purchased the Elcometer 2060 also purchased:



◀ Elcometer Film Applicators, pages 40 - 48

Elcometer Cylindrical Mandrel Tester, page 100 ▶



## Elcometer 2000 Muller Laboratory Grinder

The Elcometer 2000 is a particularly sturdy machine, enabling optimal and perfectly reproducible grinding and dispersion to be obtained in the laboratory. It has been designed to grind and disperse small amounts of raw materials for paint and varnish.

The machine consists of a frame holding 2 ground-glass plates, the lower of which is motor driven. A pre-set counter and a counter to register the total number of revolutions are included. One counts the number of revolutions and automatically stops the motor after a user defined number of revolutions, the other shows the total after each test cycle.

An amount of raw material is spread over a limited area of the lower glass plate. The mixture is ground in successive stages, for example 50 revolutions each, at a pressure, of 445 N. Between each stage, the mixture should be redistributed within the limited area.

The Elcometer 2000 Muller Grinder is suitable to prepare dispersions for testing mass colour and tinting strength and preparing small samples for use in the quality control of pigments.

The Muller grinder consists of:

- Two conditioned ground glass plates with a diameter of 210mm (8")
- A system to provide an adjustable force to the plates, 50 - 1000N (11 - 225 lbf)
- A driven base plate with constant speed drive

The Muller grinder can be calibrated against production grinders.



### Technical Specification

Part Number	Description		
UK 240V	EUR 220V	US 110V	
<b>K0UK2000M001</b>	<b>K0002000M001</b>	<b>K0US2000M001</b>	Elcometer 2000 Muller Laboratory Grinder
Speed of Rotation	UK/EUR (50Hz): 80rpm US (60Hz): 76rpm		
Dimensions	380 x 540 x 500mm (15 x 21.3 x 19.7")		
Weight	59.6kg (131lb)		
Packing List	Elcometer 2000 Muller Laboratory Grinder, 2 ground glass plates and operating instructions		

*Can be used in accordance with: (see Standards Explained inside Front Cover)*

**ASTM D 387, ASTM D 332-B, ISO 8780-5, ISO 787/16, NFT31-210-5, NF T30-227**

### Accessories

<b>KT002000P001</b>	Ground Glass Plates (2 pieces)
---------------------	--------------------------------

## Elcometer 7951 Minimix Paint Mixer

The Elcometer 7951 Paint Mixer is a very effective device for mixing and blending pigments and additives into a coating.

Easy to use, efficient, quiet and safe, the Elcometer 7951 has a range of features, which include:

- Visual display of time selected and countdown in seconds
- 30, 45, and 90 seconds shaking cycles
- On-screen operation instructions
- Door lock delay keeps door locked until all movement has stopped
- Switches off if the paint can becomes loose
- Machines will not run if no paint can is present or if the paint can has not been properly clamped
- Override facility for shaking difficult plastic containers
- Enclosed cabinet for improved Health and Safety



### Technical Specification

Part Number	Description
<b>K0UK7951M001</b>	Elcometer 7951 Paint Mixer UK (240V)
<b>K0007951M001</b>	Elcometer 7951 Paint Mixer EUR (220V)
Can Size	5 Litre (1.3 US Gallon)
Maximum Can Diameter	240mm (9.4")
Maximum Can Height	260mm (10.2")
Maximum Can Weight	12kg (26.4lb)
Dimensions	550 x 580 x 750mm (21.6 x 22.8 x 29.5")
Weight	Approximately 40kg (88.2lb)
Packing List	Elcometer 7951 Minimix Paint Mixer and operating instructions

## Viscosity Cup Conversion

The table below lists the major flow cup types together with a conversion chart of Efflux Time (in seconds) to Viscosity in Centistokes (cSt). It has been constructed from the various International Standard Calculators.

Each cup design is unique, care must be taken when comparing viscosity values between different cup types. These values are the absolute values and do not include the allowed tolerances, as these differ considerably between each of the Standards.

Viscosity Cup Type

Time (seconds)	DIN		BS				ISO				FORD / ASTM				ZAHN					SHELL					
	4	2	3	4	5	6	3	4	5	6	1	2	3	4	1	2	3	4	5	1	2	3	4	5	6
15	38	6.4		19	40	234			35	66			19	40		4	88	148	322			20	48	91	235
16	45	6.8	3	24	48	262			39	75			22	44		7	99	163	345			21	52	98	251
17	51	7.3	5	28	56	290			43	84			24	48		11	111	178	368			23	55	104	267
18	57	7.7	7	32	64	317			47	93			26	52		14	123	192	391	1.1	7.5	24	59	111	284
19	63	8.1	9	35	72	343			51	101		1	29	56		18	135	207	414	1.4	8.1	26	62	117	300
20	69	8.6	11	39	79	369			55	110		3	31	60		21	146	222	437	1.6	8.6	27	66	124	316
21	74	9.0	13	43	86	395			58	118		4	33	64		25	158	237	460	1.8	9.2	29	69	130	332
22	80	9.4	15	47	93	420			62	126		6	36	67		28	170	252	483	2.0	9.8	30	72	137	348
23	85	9.8	17	50	100	445	1		66	134		7	38	71		32	181	266	506	2.3	10.4	32	76	143	365
24	91	10.3	18	54	107	470	2		70	142		9	40	75		35	193	281	529	2.5	10.9	33	79	150	381
25	96	10.7	20	57	114	494	3		73	150		10	43	79		39	205	296	552	2.7	11.5	35	83	156	397
26	101	11.1	22	60	120	519	4		77	157		12	45	83		42	216	311	575	2.9	12.1	36	86	163	413
27	107	11.5	23	64	127	543	4.5		80	165		13	47	87		46	228	326	598	3.2	12.7	38	90	169	429
28	112	12.0	25	67	133	567	5		84	173		14	49	91		49	240	340	621	3.4	13.2	39	93	176	446
29	117	12.4	26	70	140	591	6		88	180		16	52	94		53	252	355	644	3.6	13.8	41	97	182	462
30	122	12.8	28	73	146	614	6.6		91	188		17	54	98	1	56	263	370	667	3.8	14.4	42	100	189	478
31	127	13.3	30	77	153	638	7.3		95	196		19	56	102	2	60	275	385	690	4.1	15.0	44	104	195	494
32	132	13.7	31	80	159	662	7.9		98	203		20	59	106	3	63	287	400	713	4.3	15.6	45	107	202	510
33	137	14.1	33	83	165	685	8.6		102	210		22	61	110	4	67	298	414	736	4.5	16.1	47	110	208	527
34	142	14.5	34	86	171	709	9.2		105	218		23	63	114	6	70	310	429	759	4.7	16.7	48	114	215	543
35	147	15.0	35	89	177	732	9.8		109	225		24	66	117	7	74	322	444	782	5.0	17.3	50	117	221	559
36	152	15.4	37	92	184	755	10.4		112	233		26	68	121	8	77	333	459	805	5.2	17.9	51	121	228	575
37	157	15.8	38	96	190	778	11.0		115	240		27	70	125	9	81	345	474	828	5.4	18.4	53	124	234	591
38	162	16.3	40	99	196	801	11.6		119	247	1.5	29	73	129	10	84	357	488	851	5.6	19.0	54	128	241	608
39	167	16.7	41	102	202	825	12.1		122	254	2.0	30	75	133	11	88	369	503	874	5.9	19.6	56	131	247	624
40	172	17.1	43	105	208	848	12.7		126	262	2.5	32	77	137	12	91	380	518	897	6.1	20.2	57	135	254	640
41	176	17.5	44	108	214	871	13.3		129	269	3.0	33	80	141	13	95	392	533	920	6.3	20.7	59	138	260	656
42	181	18.0	45	111	220	893	13.8		133	276	3.5	35	82	144	14	98	404	548	943	6.6	21.3	60	141	267	672
43	186	18.4	47	114	226	916	14.4		136	283	4.0	36	84	148	15	102	415	562	966	6.8	21.9	62	145	273	689
44	191	18.8	48	117	232	939	14.9		139	291	4.5	37	86	152	17	105	427	577	989	7.0	22.5	63	148	280	705
45	196	19.2	50	120	238	962	15.5		143	298	5.0	39	89	156	18	109	439	592	1012	7.2	23.0	65	152	286	721
46	200	19.7	51	123	244	985	16.0		146	305	5.5	40	91	160	19	112	450	607	1035	7.5	23.6	66	155	293	737
47	205	20.1	52	126	250	1008	16.6		149	312	6.0	42	93	164	20	116	462	622	1058	7.7	24.2	68	159	299	753
48	210	20.5	54	129	255	1030	17.1		153	319	6.5	43	96	168	21	119	474	636	1081	7.9	24.8	69	162	306	770
49	215	21.0	55	132	261	1053	17.6		156	326	7.0	45	98	171	22	123	486	651	1104	8.1	25.3	71	166	312	786
50	219	21.4	56	135	267	1076	18.2		160	334	7.5	46	100	175	23	126	497	666	1127	8.4	25.9	72	169	319	802
51	224	21.8	58	138	273	1099	18.7		163	341	8.0	48	103	179	24	130	509	681	1150	8.6	26.5	74	173	325	818
52	229	22.2	59	141	279	1121	19.2		166	348	8.5	49	105	183	25	133	521	696	1173	8.8	27.1	76	176	332	834
53	234	22.7	60	144	285	1144	19.7		170	355	8.8	50	107	187	26	137	532	710	1196	9.0	27.6	77	179	338	851
54	238	23.1	62	147	291	1166	20.2		173	362	9.0	52	110	191	28	140	544	725	1219	9.3	28.2	79	183	345	867
55	243	23.5	63	150	297	1189	20.7		176	369	9.8	53	112	194	29	144	556	740	1242	9.5	28.8	80	186	351	883
56	248	24.0	64	153	302	1212	21.2		180	376	10.3	55	114	198	30	147	567	755	1265	9.7	29.4	82	190	358	899
57	253	24.4	66	156	308	1234	21.7		183	383	10.8	56	116	202	31	151	579	770	1288	9.9	30.0	83	193	364	915
58	257	24.8	67	159	314	1257	22.2		186	390	11.3	58	119	206	32	154	591	784	1311	10.2	30.5	85	197	371	932
59	262	25.2	68	162	320	1279	22.7		190	397	11.8	59	121	210	33	158	603	799	1334	10.4	31.1	86	200	377	948
60	267	25.7	70	165	326	1302	23.2		193	405	12.3	60	123	214	34	161	614	814	1357	10.6	31.7	88	204	384	964
65	290	27.8	76	179	354	1414	26		210	440	15	68	135	233	40	179	673	888	1472	11.8	34.6	95	221	416	1045
70	313	29.9	83	194	383	1526	28		226	475	17	75	147	252	45	196	731	962	1587	12.9	37.4	103	238	449	1126
75	337	32.1	89	208	412	1638	31	3	243	510	20	82	158	271	51	214	790	1036	1702	14.0	40.3	110	255	481	1207
80	360	34.2	96	223	441	1750	33	16	260	545	22	89	170	291	56	231	848	1110	1817	15.1	43.2	118	273	514	1288
85	383	36.4	102	237	469	1861	35	28	276	580	25	96	181	310	61.6	249	907	1184	1932	16.3	46.1	125	290	546	1369
90	406	38.5	108	252	498	1973	38	40	293	615	27	104	193	329	67	266	965	1258	2047	17.4	49.0	133	307	579	1450
100	452	42.8	121	280	554	2195	42	62	326	684	32	118	216	368	78	301	1082	1406	2277	19.7	54.7	148	342	644	1612
110	499	47.0	134	309	611	2418	47	83	359	754	37	132	239	406	89	336	1199	1554	2507	21.9	60.5	163	376	709	1774
120	545	51.3	146	338	668	2640	51	102	392	823	42	147	262	445	100	371	1316	1702	2737	24.2	66.2	178	411	774	1936
130	591	55.6	159	366	724	2862	56	120	425	893	47	161	285	483	111	406	1433	1850	2967	26.4	72.0	193	445	839	2098
140	637	59.9	171	395	781	3084	61	138	458	962	51	176	308	522	122	441	1550	1998	3197	28.7	77.8	208	480	904	2260
150	682	64.2	184	424	837	3305	65	156	491	1031	56	190	331	560	133	476	1667	2146	3427	31.0	83.5	223	514	969	2422

All measurements are in Centistokes (cSt). Centipoise (cP) = cSt x product density

## Viscosity

Viscosity is perceived as 'thickness' or resistance to pouring, but there is more to viscosity than this. All fluids have an internal friction between molecules, which determines how well fluid flows. Due to this internal friction, energy is required to move the liquid and viscosity is the measure of the resistance to flow.

Fluids are categorised as Newtonian or non-Newtonian.

- **Newtonian fluids**, such as water and some oils, are fluids that continue to flow at a given temperature, regardless of the forces acting on it. No matter how fast it is stirred or mixed, Newtonian fluids will always behave in the same manner. Newtonian fluids are generally measured with flow and dip viscosity cups.
- **Non-Newtonian fluids**, such as paints and ketchup, are fluids which change viscosity when a force is applied. There are several different categories and sub-categories of non-Newtonian fluids, they can be described as the following:

*Thixotropic* - substances which are gel-like at rest but liquid when agitated, eg: non-drip paints, tomato ketchup and most varieties of honey.

*Rheoplectic* - substances where viscosity increases with duration of stress, eg: some lubricants.

*Pseudoplastics* - also known as shear thinning - the viscosity decreases with increased shear rate, eg: blood, gelatin and clay.

*Dilatant* - also known as shear thickening - the viscosity increases with increased shear rate, eg: suspensions of rice, corn starch or concentrated sugar solution.

## Measuring Viscosity

Non-Newtonian fluids are measured using Rotational viscometers (please see pages 19-25).

Elcometer manufactures and supplies a wide range of viscosity gauges from flow cups to dip cups to rotational viscometers.

- **Flow Cups:** The process of flow through an orifice can often be used as a relative measurement and classification of viscosity. This measured kinematic viscosity is generally expressed in seconds of flow time which can be converted into Centistokes using a viscosity disc calculator. (See table opposite).
- **Dip Cups:** Using the same principle as flow cups, dip cups - Frikmar, Zahn, Shell etc. - can be used to provide a quick viscosity measurement either on-site or on the shop-floor.
- **Rotational:** Rotational viscometers are used to determine the viscosity of liquids which do not depend solely on temperature and pressure.
- **Flow Measurement:** Simple to use instruments that measure the fluidity and flow of coatings, especially thick or paste-like materials.



## Elcometer Viscosity Dip Cups

Elcometer viscosity dip cups are ideal for the quick testing of the viscosity of paints, varnishes and similar products during manufacturing processes.

Dip cups are dipped into the substance being tested and the viscosity is determined by the time it takes for the cup to empty with a steady flow.

Elcometer has a range of viscosity dip cups which includes Frikmar, Zahn, Shell, and Lory dip cups.

## Elcometer Frikmar Viscosity Dip Cups

Thanks to its handle, this cup is very easy to use to perform checks on site or during the manufacturing process. It is ideal for measuring the consistency of paints, varnishes and similar products.

The cup is first dipped into the product to be measured, then the contents empty through the orifice. The measured kinematic viscosity is generally expressed in seconds (s) flow time, which can be converted to Centistokes (cSt) if the Standard stipulates a conversion method.

Several ranges are available, according to the Standards being used; from 7 to 1100cSt.



### Technical Specification

certificate available

#### DIN Viscosity Dip Cups

Part Number	Description	Cup Number	Orifice Diameter	Range (cSt) <sup>1</sup>
K0002434M001	Elcometer 2434/1 DIN Dip Cup	2	2mm	-
K0002434M002	Elcometer 2434/2 DIN Dip Cup	4	4mm	96 - 683
K0002434M003	Elcometer 2434/3 DIN Dip Cup	6	5.98mm	-
K0002434M004	Elcometer 2434/4 DIN Dip Cup	8	8mm	-
K0002434M001C	Elcometer 2434/1 with calibration certificate	2 <sup>(d)</sup>	2mm	-
K0002434M002C	Elcometer 2434/2 with calibration certificate	4 <sup>(e)</sup>	4mm	96 - 683
K0002434M003C	Elcometer 2434/3 with calibration certificate	6 <sup>(d)</sup>	6mm	-
K0002434M004C	Elcometer 2434/4 with calibration certificate	8 <sup>(d)</sup>	8mm	-

Can be used in accordance with: (see Standards Explained inside Front Cover)  
DIN 53211 (cup 4 only)

#### FORD/ASTM Viscosity Dip Cups

Part Number	Description	Cup Number	Orifice Diameter	Range (cSt) <sup>1</sup>
K0002435M001	Elcometer 2435/1 FORD/ASTM Dip Cup	4	4.12mm	70 - 370
K0002435M001C	Elcometer 2435/1 with calibration certificate	4 <sup>(e)</sup>	4.12mm	70 - 370

Can be used in accordance with: (see Standards Explained inside Front Cover)

ASTM D 1200

(1) For Information Only

(d) Dimensional Certificate

(e) Efflux Time Certificate

## Technical Specification

**C** certificate available

### ISO Viscosity Dip Cups

Part Number	Description	Cup Number	Orifice Diameter	Range (cSt) <sup>1</sup>
K0002437M002	Elcometer 2437/2 ISO Dip Cup	3	2.9mm	7 - 42
K0002437M003	Elcometer 2437/3 ISO Dip Cup	4	4mm	34 - 135
K0002437M006	Elcometer 2437/6 ISO Dip Cup	5	5mm	91 - 326
K0002437M004	Elcometer 2437/4 ISO Dip Cup	6	6mm	188 - 684
K0002437M005	Elcometer 2437/5 ISO Dip Cup	8	8mm	-
K0002437M002C	Elcometer 2437/2 with calibration certificate	3 (e)	3mm	7 - 42
K0002437M003C	Elcometer 2437/3 with calibration certificate	4 (e)	4mm	34 - 135
K0002437M006C	Elcometer 2437/6 with calibration certificate	5 (e)	5mm	91 - 326
K0002437M004C	Elcometer 2437/4 with calibration certificate	6 (e)	6mm	188 - 684
K0002437M005C	Elcometer 2437/5 with calibration certificate	8 (d)	8mm	-

Can be used in accordance with: (see Standards Explained inside Front Cover)

ASTM D 5125, DIN 53224, EN 535, ISO 2431, NBN T22-108, NF T30-014, NF T30-070

(1) For Information Only

(d) Dimensional Certificate

(e) Efflux Time Certificate

### AFNOR Viscosity Dip Cups

Part Number	Description	Cup Number	Orifice Diameter	Range (cSt) <sup>1</sup>
K0002436M001	Elcometer 2436/1 AFNOR Dip Cup	4	3.99mm	50 - 1100

Can be used in accordance with: (see Standards Explained inside Front Cover)

AFNOR NF T30-014

## Accessories

For a full range of accessories see page 17

(1) For Information Only

(d) Dimensional Certificate

(e) Efflux Time Certificate

Customers who have purchased the Elcometer Dip Cups also purchased:



◀ Elcometer 2400 Conversion Disc, page 17

Elcometer 2300 Rotational Viscometer, page 21 - 27 ▶



## Elcometer 2210 Zahn Viscosity Dip Cups

The Elcometer 2210 Zahn Dip Cup is a small U-shaped cup suspended from a looped wire. This method is ideal for measuring the consistency of paints, varnishes and similar products.

Simply dip the cup into the product to be measured, lift it out and measure how long it takes for the contents to empty through the orifice.

There are five cups with five different orifices sizes available, ranging from 5 to 1840cSt.



### Technical Specification

certificate available

Part Number	Description	Cup Number	Orifice Diameter	Range (cSt) <sup>1</sup>
K0002210M001	Elcometer 2210/1 Zahn Dip Cup	1	2mm	5 - 56
K0002210M002	Elcometer 2210/2 Zahn Dip Cup	2	2.7mm	21 - 231
K0002210M003	Elcometer 2210/3 Zahn Dip Cup	3	3.8mm	146 - 848
K0002210M004	Elcometer 2210/4 Zahn Dip Cup	4	4.3mm	222 - 1110
K0002210M005	Elcometer 2210/5 Zahn Dip Cup	5	5.3mm	460 - 1840
K0002210M001C	Elcometer 2210/1 with calibration certificate	1 <sup>(e)</sup>	1.8mm	5 - 56
K0002210M002C	Elcometer 2210/2 with calibration certificate	2 <sup>(e)</sup>	2.7mm	21 - 231
K0002210M003C	Elcometer 2210/3 with calibration certificate	3 <sup>(e)</sup>	3.8mm	146 - 848
K0002210M004C	Elcometer 2210/4 with calibration certificate	4 <sup>(e)</sup>	4.3mm	222 - 1110
K0002210M005C	Elcometer 2210/5 with calibration certificate	5 <sup>(e)</sup>	5.3mm	460 - 1840

Can be used in accordance with: (see Standards Explained inside Front Cover)

ASTM D 1084, **ASTM D 4212**, ASTM D 3794

(1) For Information Only

(e) Efflux Time Certificate

### Accessories

For a full range of accessories, see page 17



## Elcometer 2310 Shell Viscosity Dip Cups

The Elcometer 2310 Shell Viscosity Dip Cups are stainless steel cups for quick measurements on-site or during production. These cups are often used in the printing or ink industry.

Simply dip the cup into the product to be measured, lift it out and measure how long it takes for the contents to empty through the orifice.

The measured kinematic viscosity is generally expressed in seconds (s) flow time, which can be converted into Centistokes (cSt).

There are six different orifice sizes available, for measurements between 2 and 1300cSt.



### Technical Specification

**C** certificate available

Part Number	Description	Cup Number	Orifice Diameter	Range (cSt) <sup>1</sup>
K0002310M001	Elcometer 2310/1 Shell Dip Cup	1	1.8mm	2 - 20
K0002310M002	Elcometer 2310/2 Shell Dip Cup	2	2.4mm	10 - 50
K0002310M003	Elcometer 2310/3 Shell Dip Cup	3	3.1mm	30 - 120
K0002310M004	Elcometer 2310/4 Shell Dip Cup	4	3.8mm	70 - 270
K0002310M005	Elcometer 2310/5 Shell Dip Cup	5	4.6mm	125 - 520
K0002310M006	Elcometer 2310/6 Shell Dip Cup	6	5.8mm	320 - 1300
K0002310M001C	Elcometer 2310/1 with calibration certificate	1 (e)	1.8mm	2 - 20
K0002310M002C	Elcometer 2310/2 with calibration certificate	2 (e)	2.4mm	10 - 50
K0002310M003C	Elcometer 2310/3 with calibration certificate	3 (e)	3.1mm	30 - 120
K0002310M004C	Elcometer 2310/4 with calibration certificate	4 (e)	3.8mm	70 - 270
K0002310M005C	Elcometer 2310/5 with calibration certificate	5 (e)	4.6mm	125 - 520
K0002310M006C	Elcometer 2310/6 with calibration certificate	6 (e)	5.8mm	320 - 1300

Can be used in accordance with: (see Standards Explained inside Front Cover)  
ASTM D 4212

(1) For Information Only

(e) Efflux Time Certificate

### Accessories

For a full range of accessories, see page 17

## Elcometer 2215 Lory Viscosity Cup

The Elcometer 2215 Lory Viscosity Cup is a conventional cylindrical cup with a needle fixed into the bottom for quick measurements on-site or during production.

The cup is first dipped into the product to be measured, then empties through the escape hole. Unlike other Viscosity cups, the flow time is measured as soon as the point of the needle appears.



Technical Specification			
Part Number	Model	Cup Number	Range (cSt) <sup>1</sup>
<b>K0002215M001</b>	Elcometer 2215	1	50 - 1100

**C** certificate available

(1) For Information Only

## Elcometer Dip Cup Stands

The Elcometer Dip Cup Stands provide a useful, compact way of storing dip cups when they are not in use.

The stand has been designed specifically to hold up to 5 cups. Suitable for Elcometer Frikmar, Zahn, Shell and Lory Viscosity Dip Cups.

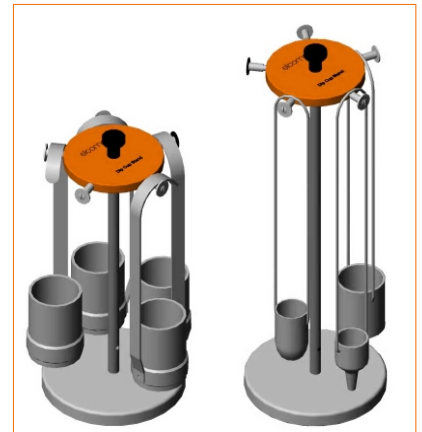

Technical Specification	
Part Number	Description
<b>K0002999M001</b>	Elcometer Dip Cup Stand for Zahn, Shell & Lory Cups
<b>K0002999M002</b>	Elcometer Dip Cup Stand for Frikmar Cups

## Viscosity Flow Cups

Viscosity Flow cups are very easy to use instruments of anodized aluminium with a stainless steel orifice, for measuring the consistency of paints, varnishes and similar products. The measured kinematic viscosity is generally expressed in seconds(s) flow time. If the Standards stipulate conversion methods the flow time can be converted into Centistokes (cSt).

Elcometer offers the option to order viscosity cups complete with calibration certificates which offer traceability and assurance that the viscosity cups have been individually tested and comply to Standards. The cups can be supplied separately or with an adjustable stand which includes a precision level and an overflow glass draw plate. The stand can also be supplied with a flow jacket for temperature control (thermojacket). Several ranges are available according to Standards, from 5 to 5100cSt; please refer to the table on page 8. For a full range of accessories, see page 17.



### Technical Specification

**C,A** certificate available

#### ISO Viscosity Cups

Part Number	Description	Cup Number	Orifice Diameter	Range (cSt) <sup>1</sup>
K0002353M001	Elcometer 2353/1 ISO Viscosity Cup	3	3mm	7 - 42
K0002353M002	Elcometer 2353/2 ISO Viscosity Cup	4	3.95mm	34 - 135
K0002353M003	Elcometer 2353/3 ISO Viscosity Cup	5	5mm	91 - 326
K0002353M004	Elcometer 2353/4 ISO Viscosity Cup	6	6mm	188 - 684
K0002353M005	Elcometer 2353/5 ISO Viscosity Cup	8	7.93mm	-
K0002353M001C	Elcometer 2353/1 with calibration certificate	3 (e)	3mm	7 - 42
K0002353M002C	Elcometer 2353/2 with calibration certificate	4 (e)	4mm	34 - 135
K0002353M003C	Elcometer 2353/3 with calibration certificate	5 (e)	5mm	91 - 326
K0002353M004C	Elcometer 2353/4 with calibration certificate	6 (e)	6mm	188 - 684
K0002353M005C	Elcometer 2353/5 with calibration certificate	8 (d)	8mm	-

Can be used in accordance with: (see Standards Explained inside Front Cover)

ASTM D 5125, DIN 53224, EN 535, ISO 2431, NBN T22-108, NF T30-070

#### BS Viscosity Cups

Part Number	Description	Cup Number	Orifice Diameter	Range (cSt) <sup>1</sup>
K0002354M001	Elcometer 2354/1 BS Viscosity Cup	2	2.38mm	6 - 43
K0002354M002	Elcometer 2354/2 BS Viscosity Cup	3	3.17mm	28 - 150
K0002354M003	Elcometer 2354/3 BS Viscosity Cup	4	3.97mm	89 - 340
K0002354M004	Elcometer 2354/4 BS Viscosity Cup	5	4.76mm	79 - 441
K0002354M005	Elcometer 2354/5 BS Viscosity Cup	6	7.14mm	369 - 1302
K0002354M001C	Elcometer 2354/1 with calibration certificate	2 (d)	2mm	6 - 43
K0002354M002C	Elcometer 2354/2 with calibration certificate	3 (d)	3mm	28 - 150
K0002354M003C	Elcometer 2354/3 with calibration certificate	4 (d)	4mm	89 - 340
K0002354M004C	Elcometer 2354/4 with calibration certificate	5 (d)	5mm	79 - 441
K0002354M005C	Elcometer 2354/5 with calibration certificate	6 (d)	6mm	369 - 1302

Can be used in accordance with: (see Standards Explained inside Front Cover)

BS 3900 A6:1971, AS/NZS 1580.214.2 (cup 4 only)

(1) For Information Only

(d) Dimensional Certificate

(e) Efflux Time Certificate

## Viscosity Flow Cups

Technical Specification

certificate available

### FORD/ASTM Viscosity Cups

Part Number	Description	Cup Number	Orifice Diameter	Range (cSt) <sup>1</sup>
K0002351M001	Elcometer 2351/1 FORD/ASTM Viscosity Cup	1	1.90mm	10 - 35
K0002351M002	Elcometer 2351/2 FORD/ASTM Viscosity Cup	2	2.53mm	25 - 120
K0002351M003	Elcometer 2351/3 FORD/ASTM Viscosity Cup	3	3.40mm	49 - 220
K0002351M004	Elcometer 2351/4 FORD/ASTM Viscosity Cup	4	4.12mm	70 - 370
K0002351M005	Elcometer 2351/5 FORD/ASTM Viscosity Cup	5	5.20mm	200 - 1200
K0002351M001C	Elcometer 2351/1 with calibration certificate	1 <sup>(e)</sup>	1.90mm	10 - 35
K0002351M002C	Elcometer 2351/2 with calibration certificate	2 <sup>(e)</sup>	2.53mm	25 - 120
K0002351M003C	Elcometer 2351/3 with calibration certificate	3 <sup>(e)</sup>	3.40mm	49 - 220
K0002351M004C	Elcometer 2351/4 with calibration certificate	4 <sup>(e)</sup>	4.12mm	70 - 370
K0002351M005C	Elcometer 2351/5 with calibration certificate	5 <sup>(e)</sup>	5.20mm	200 - 1200

Can be used in accordance with: (see Standards Explained inside Front Cover)  
ASTM D1200

### DIN Viscosity Cups

Part Number	Description	Cup Number	Orifice Diameter	Range (cSt) <sup>1</sup>
K0002350M001	Elcometer 2350/1 DIN Viscosity Cup	2	1.96mm	-
K0002350M002	Elcometer 2350/2 DIN Viscosity Cup	4	4mm	96 - 683
K0002350M003	Elcometer 2350/3 DIN Viscosity Cup	6	6mm	-
K0002350M004	Elcometer 2350/4 DIN Viscosity Cup	8	8mm	-
K0002350M001C	Elcometer 2350/1 with calibration certificate	2 <sup>(d)</sup>	2mm	-
K0002350M002C	Elcometer 2350/2 with calibration certificate	4 <sup>(e)</sup>	4mm	96 - 683
K0002350M003C	Elcometer 2350/3 with calibration certificate	6 <sup>(d)</sup>	6mm	-
K0002350M004C	Elcometer 2350/4 with calibration certificate	8 <sup>(d)</sup>	8mm	-

Can be used in accordance with: (see Standards Explained inside Front Cover)  
DIN 53211 (cup 4 only)

### AFNOR Viscosity Cups

Part Number	Description	Cup Number	Orifice Diameter	Range (cSt) <sup>1</sup>
K0002352M001	Elcometer 2352/1 AFNOR Viscosity Cup	2.5	2.46mm	5 - 140
K0002352M002	Elcometer 2352/2 AFNOR Viscosity Cup	4	4mm	50 - 1100
K0002352M003	Elcometer 2352/3 AFNOR Viscosity Cup	6	6mm	510 - 5100

Can be used in accordance with: (see Standards Explained inside Front Cover)  
NF T30-014

(1) For Information Only

(d) Dimensional Certificate

(e) Efflux Time Certificate

## Viscosity Cup Accessories



KT002400N001 Stand with Bubble Level for Cup and Glass Draw Plate  
 KT002400P001 Bubble Level for Viscosity Cup  
 KT002400P999 Viscosity Glass Draw Plate



KT002400N002 Double-walled Stand with Thermo jacket



K0007300M201 Elcometer 7300 High precision stopwatch.  
 Measuring intervals: 1/100 second for 30 minutes and 1 second for 24 hours. Time/calendar display, 12/24 hour mode



KT002400N003 Elcometer 2400 Conversion Disc allowing viscosity (cSt) and flow times of different cups to be compared.  
 Front: No.4 cups according to AFNOR, BS, NF, ASTM, DIN, Zahn 2  
 Back: No.3-4-5-6 cups according to ISO and Zahn 3



T1164441- Spirit Thermometer in °C  
 T1164442- Spirit Thermometer in °F



G212----1 Elcometer 212/1 Digital Pocket Thermometer (°C) with Needle/Liquid Probe



G213----2 Elcometer 213/2 Digital Thermometer (°C/°F)  
 T2136390- Elcometer 213/2 Liquid Probe

## Elcometer Viscosity Cup Standard Calibration

In order to check the viscosity cup's calibration or to certify it for ISO purposes, it is imperative that viscosity cup standard calibration oils are used.

Standard oils have a specific drain time, dependent upon the viscosity cup type (Ford, Shell, Zahn etc.) and the orifice or cup number used.

To check the viscosity cup, use the standard viscosity oils in place of the liquid and measure the drain time.

Specific calibration oils can only be used with specific flow and dip cups. Please use the table below to determine which calibration oil is required with each cup, or contact Elcometer. Viscosity oils are supplied in ½ litre (1 pint) bottles.



### Technical Specification

certificate available

Part Number	Range at 25°C (77°F)	Cup Type	Cup Number	Model	Orifice Diameter
K0002410M021	20 - 34cSt	Zahn Dip Cup	1	Elcometer 2210/1	2mm
K0002410M022	60 - 120cSt	Zahn Dip Cup	2	Elcometer 2210/2	2.7mm
K0002410M023	100 - 230cSt	Zahn Dip Cup	3	Elcometer 2210/3	3.8mm
K0002410M024	200 - 460cSt	Zahn Dip Cup	3	Elcometer 2210/3	3.8mm
K0002410M025	350 - 850cSt	Zahn Dip Cup	4	Elcometer 2210/4	4.3mm
K0002410M026	600 - 1600cSt	Zahn Dip Cup	5	Elcometer 2210/5	5.3mm
K0002410M021	20 - 34cSt	Shell Dip Cup	2	Elcometer 2310/2	2.4mm
K0002410M022	60 - 120cSt	Shell Dip Cup	4	Elcometer 2310/4	3.8mm
K0002410M023	100 - 230cSt	Shell Dip Cup	5	Elcometer 2310/5	4.6mm
K0002410M024	200 - 460cSt	Shell Dip Cup	6	Elcometer 2310/6	5.8mm
K0002410M022	60 - 120cSt	DIN Flow Cup	4	Elcometer 2350/2	4mm
K0002410M023	100 - 230cSt	DIN Flow Cup	4	Elcometer 2350/2	4mm
K0002410M024	200 - 460cSt	DIN Flow Cup	4	Elcometer 2350/2	4mm
K0002410M021	20 - 34cSt	ASTM/FORD Flow Cup	2	Elcometer 2531/2	2.53mm
K0002410M022	60 - 120cSt	ASTM/FORD Flow Cup	3	Elcometer 2531/3	3.40mm
K0002410M023	100 - 230cSt	ASTM/FORD Flow Cup	4	Elcometer 2351/4	4.12mm
K0002410M021	20 - 34cSt	ISO Flow Cup	3	Elcometer 2353/1	3mm
K0002410M022	60 - 120cSt	ISO Flow Cup	4	Elcometer 2353/2	3.95mm
K0002410M023	100 - 230cSt	ISO Flow Cup	6	Elcometer 2353/4	6mm
K0002410M024	200 - 460cSt	ISO Flow Cup	6	Elcometer 2353/4	6mm
K0002410M022	60 - 120cSt	DIN Frikmar Dip Cup	4	Elcometer 2434/2	4mm
K0002410M023	100 - 230cSt	DIN Frikmar Dip Cup	4	Elcometer 2434/2	4mm
K0002410M024	200 - 460cSt	DIN Frikmar Dip Cup	4	Elcometer 2434/2	4mm
K0002410M021	20 - 34cSt	ISO Frikmar Dip Cup	3	Elcometer 2437/2	3mm
K0002410M022	60 - 120cSt	ISO Frikmar Dip Cup	4	Elcometer 2437/3	4mm
K0002410M023	100 - 230cSt	ISO Frikmar Dip Cup	6	Elcometer 2437/4	6mm
K0002410M024	200 - 460cSt	ISO Frikmar Dip Cup	6	Elcometer 2437/4	6mm

## Rotational Viscosity

Rotational viscometers gather data on a material's viscosity behaviour under different conditions. Rotational viscometers consist of two parts - a head unit with a motor and a spindle that is driven by the motor. The viscosity is determined by measuring the resistance of the spindle rotating in the sample. Rotational viscometers are ideal for determining the viscosity of liquids which do not depend solely on temperature and pressure.

### Definitions:

- Viscosity:** A measure of the resistance of a liquid to flow
- Thixotropic:** Describes materials that are gel-like at rest but liquid when agitated
- Centipoise:** A unit of measurement of which water is the standard at 1cP
- Newtonian Liquids:** The viscosity of a Newtonian liquid is dependent only on temperature, not on shear rate and time
- Non-Newtonian Liquids:** Time dependent. The viscosity of the liquid is dependent on temperature, shear rate and time

Depending on how viscosity changes with time, the flow behaviour is characterised as:

- Thixotropic:** Time thinning, i.e. viscosity decreases with time  
Thixotropic liquids are quite common in the chemical and food industries
- Rheopetic:** Time thickening, i.e. viscosity increases with time. Rheopetic liquids are very rare. Some liquids show time thinning behaviour due to breakdown of the structure. This phenomenon is sometimes known as *Rheomaiaxis*

Depending on how viscosity changes with shear rate, the flow behaviour is characterised as:

- Pseudoplastics:** Also known as shear thinning, the viscosity decreases with increased shear rate
- Dilatant:** Also known as shear thickening, the viscosity increases with increased shear rate
- Plastic:** Exhibits a so-called yield value, i.e. a certain shear stress must be applied before a flow occurs



## Elcometer 2200 Krebs Digital Viscometer

This simple to use rotational viscometer consists of a spindle and paddle and is ideal for those who require measurements of viscosity in Krebs Units, Centrepoise or Grams.

The spindle is rotated at 200rpm when the paddle is immersed in the sample coating. The Elcometer 2200 automatically calculates the viscosity value from the power required to maintain the spindle at 200rpm.

The Elcometer 2200 can provide readings in 3 different units of measure at the flick of a switch:

- Centipoise
- Krebs Units
- Grams

The Elcometer 2200/2 is fitted with an air purge for use in hazardous environments.



### Technical Specification

certificate available

Part Number	Description		
UK 240V	EUR 220V	US 110V	
<a href="#">K0UK2200M202</a>	<a href="#">K0002200M202</a>	<a href="#">K0US2200M202</a>	Elcometer 2200/1 Krebs Viscometer
<a href="#">K0UK2200M203</a>	<a href="#">K0002200M203</a>	<a href="#">K0US2200M203</a>	Elcometer 2200/2 Krebs Viscometer with Air Purge
Range Centipoise	150 - 4000cP		
Range Krebs Units	40 - 140KU		
Range Grams	35 - 1150g		
Resolution Centipoise	1.0cP		
Range Krebs Units	0.1KU		
Range Grams	1.0g		
Accuracy	±1.0% of full scale		
Spindle Rotation Speed	200rpm ±0.2rpm		
Dimensions	381 x 279 x 508mm (15 x 11 x 20")		
Weight	22lb (10kg)		
Packing List	Elcometer 2200 Krebs Digital Viscometer		

Can be used in accordance with: (see Standards Explained inside Front Cover)

[ASTM D 562](#), [ASTM D 1084-C](#), [AS/NZS 1580.214.1](#)



## Elcometer 2300 Digital Rotational Viscometer

The Elcometer 2300 range of rotational viscometers can be used to measure the viscosity of liquids in accordance with ISO 2555 and several ASTM standards. The Elcometer 2300 is available in four versions, with a choice of low to medium or medium to high viscosity ranges, either manually or PC controlled.

4 versions in the range cover low to medium or medium to high viscosity and are either manually or computer controlled

Clear, backlit LCD shows the viscosity reading in cP or mPas, spindle rotation speed, % torque, sample temperature, auto range, shear rate and shear stress

Easy to use three-button control panel

Temperature probe for accurate measurement of the sample

Selectable speeds provide a wide range of viscosity and shear rate measurements



Spindles are quick & easy to attach, with a wide range available to meet the users requirements

Bubble level makes it easy to ensure the viscometer is level & the spindle is vertical

Continuous sensing and display

RS232 interface allows data download and control of spindle speed and duration via PC on RV2 models

The viscometer head is fully height adjustable in order to fit the different sample containers

Audible warning if viscosity reading exceeds the optimum measuring range set by the user

The sturdy base is fully adjustable to ensure the viscometer is level



## Elcometer 2300 RV1 and RV2 Rotational Viscometers

There are four versions in the Elcometer 2300 range: RV1-L, RV1-R, RV2-L and RV2-R.

- RV1 viscometers: manually controlled
- RV2 viscometers: manually or PC controlled
- Elcometer 2300 RV1-L: Manually controlled, ideal for low to medium viscosity testing
- Elcometer 2300 RV1-R: Manually controlled, ideal for medium to high viscosity testing
- Elcometer 2300 RV2-L: PC controlled, ideal for low to medium viscosity testing
- Elcometer 2300 RV2-R: PC controlled, ideal for medium to high viscosity testing
- Spindles: Both RV1-L and RV2-L supplied with spindles L1 to L4  
Both RV1-R and RV2-R supplied with spindles R2 to R7
- Backlit LCD shows the following readings: Viscosity readings (cP or mPas), spindle rotation speed, % torque, sample temperature, auto range, shear rate & shear stress
- Bi-directional RS232 interface can be used in conjunction with ViscosityMaster™ Software (supplied)
- Measuring range: RV1-L & RV2-L 3 - 2,000,000mPas/cP  
RV1-R & RV2-R 20 - 13,000,000mPas/cP
- Speeds: 19 speeds ranging from 0.3rpm to 200rpm
- Accuracy: ±1% of full scale
- Repeatability: ±0.2%
- Sample temperature: PT100 temperature probe supplied with RV2-R



### Technical Specification

certificate available

Model		Elcometer 2300 RV1-L	Elcometer 2300 RV1-R	Elcometer 2300 RV2-L	Elcometer 2300 RV2-R
Part Number	UK 240V	K0UK2300M101	K0UK2300M102	K0UK2300M201	K0UK2300M202
	EUR 220V	K0002300M101	K0002300M102	K0002300M201	K0002300M202
	US 110V	K0US2300M101	K0US2300M102	K0US2300M201	K0US2300M202

Can be used in accordance with: (see Standards Explained inside Front Cover)

AS/NZS 1580.214.5, ASTM D 1084-B, ASTM D 2196, BS 3900 A7-2, ISO 2555, ISO 2884-2

## Technical Specification

 certificate available

Model		Elcometer 2300 RV1-L	Elcometer 2300 RV1-R	Elcometer 2300 RV2-L	Elcometer 2300 RV2-R
Part Number	UK 240V	K0UK2300M101	K0UK2300M102	K0UK2300M201	K0UK2300M202
	EUR 220V	K0002300M101	K0002300M102	K0002300M201	K0002300M202
	US 110V	K0US2300M101	K0US2300M102	K0US2300M201	K0US2300M202
Manual Control		■	■		
Manual & PC Controlled				■	■
Low to Medium Viscosity		■		■	
Medium to High Viscosity			■		■
Backlit LCD		■	■	■	■
Readings in cP & mPas		■	■	■	■
Sample Temperature Measurement		■	■	■	■
Measuring Range (mPas)		3-2,000,000	20-13,000,000	3-2,000,000	20-13,000,000
Accuracy (measure) of Full Scale		±1%	±1%	±1%	±1%
Maximum Altitude above Sea Level		2000m (6562ft)	2000m (6562ft)	2000m (6562ft)	2000m (6562ft)
Surge Class II (Domestic/Light Industry)		■	■	■	■
Contamination Level 2		■	■	■	■
Speeds (rpm)		0.3, 0.5, 0.6, 1, 1.5, 2, 2.5, 3, 4, 5, 6, 10, 12, 20, 30, 50, 60, 100, 200			
Accuracy (speed)		<0.5% of the absolute value			
PT100 Thermometer Range		-15°C to +180°C (5°F to 356°F)			
PT100 Thermometer Resolution		0.1°C (0.18°F)			
PT100 Thermometer Accuracy		±0.1°C (0.18°F)			
Power Consumption		23W			
Dimensions (of carry case)		495 x 420 x 200mm (19.5 x 16.5 x 8")			
Weight (including carry case)		9kg (20lb)			

### Packing List:

Elcometer 2300 RV1-L Spindles L1 to L4, RS232 connection cable, ViscosityMaster™ software for data transfer from viscometer to PC only

Elcometer 2300 RV1-R Spindles R2 to R7, RS232 connection cable, ViscosityMaster™ software for data transfer from viscometer to PC only

Elcometer 2300 RV2-L Spindles L1 to L4, RS232 connection cable, ViscosityMaster™ software for bi-lateral data transfer between viscometer & PC

Elcometer 2300 RV2-R Spindles R2 to R7, RS232 connection cable, ViscosityMaster™ software for bi-lateral data transfer between viscometer & PC

Can be used in accordance with: (see Standards Explained inside Front Cover)

AS/NZS 1580.214.5, ASTM D 1084-B, ASTM D 2196, BS 3900 A7-2, ISO 2555, ISO 2884-2

## Elcometer 2300 Accessories



### Spindles

Each Elcometer 2300 is supplied with a set of stainless steel spindles as standard, suitable for both Newtonian & non-Newtonian fluids.

Elcometer 2300 RV-L supplied with spindles L1-L4 for low to medium viscosity testing.

Elcometer 2300 RV-R supplied with spindles R2-R7 for medium to high viscosity testing.

A large R1 spindle (highlighted left) can be supplied upon request.

- KT00230019698** Extra spindle set, standard type L1-L4
- KT00230019699** Extra spindle set, standard type R2-R7
- KT00230019700** R1 spindle (supplied on request)



### Small Sample Adaptor

The small sample adaptor consists of a cylindrical sample chamber which can be used in conjunction with spindles TL & TR. To accurately obtain viscosity measurements, shear rate and shear stress of sample volumes between 8 - 13ml (0.27-0.44fl.oz). The TL spindles for low to medium viscosity samples and TR spindles for medium to high viscosity samples.

- Kt00230019702** Adaptor kit for small volume samples
- KT00230019784** Adaptor kit for small volume samples & integrated temperature sensor (requires a small volume spindle set)
- KT00230019703** Small volume spindle set (TL5, TL6 and TL7)
- KT00230019704** Small volume spindle set (TR8, TR9, TR10 and TR11)



### Low Viscosity Adaptor

The low viscosity adaptor consists of a cylindrical sample chamber and is supplied complete with spindle and are used to accurately obtain viscosity measurements, shear rate and shear stress of low viscosity materials from 1cP (mPa). The stainless steel chamber can hold a sample volume from 16-18ml (0.54 - 0.61fl.oz) and keep it at a constant specified temperature between 0°C and 100°C (32°F and 212°F).

- KT00230019710** Low viscosity adaptor kit with spindle



### High Temperature Adaptor

The high temperature adaptor allows precise measurement of viscosity at high temperatures. It can accurately obtain viscosity measurements, shear rate and shear stress from 1cP(mPa) up to temperatures of 200°C (392°F). The stainless steel chamber can hold a sample volume from 16-18ml (0.54-0.61fl.oz). The high temperature adaptor is ideal for use with materials such as hot resins, bitumens and oils. Each adaptor is supplied complete with a spindle.

- KT00230019711** High temperature adaptor kit with spindle

## Elcometer 2300 Spindles & Accessories



### Helical Movement Adaptor

Some materials, such as creams, pastes and gels, do not flow easily, so standard spindles and testing methods cannot be used as they create a 'hole' in the material, generating invalid results.

The measuring head, when attached to the Elcometer 2300, moves smoothly up and down and automatically stays within pre-programmed limits.

This allows the needle style spindle to cut into the material, making a helical path through the sample, making the measurement of viscosity. The kit is supplied with the motor and 6 T-shaped spindles: PA, PB, PC, PD, PE, PF.

- KT00230019705 Helical movement adaptor kit (240V UK)
- KT00230019706 Helical movement adaptor kit (220V EUR)
- KT00230019707 Helical movement adaptor kit (110V US)

## Rotational Viscosity Standard Calibration Oils



Silicone standard oils are used to check viscosity measurements. The values are given for 6 different temperatures between 20°C and 27°C (68°F and 80°F).

The oils listed below are specifically manufactured for use with Elcometer Rotational viscometers and values quoted are nominal at 25°C (77°F).

- KT009999N001 Standard calibration oil (60ml/2floz) - 300cPs
- KT009999N002 Standard calibration oil (60ml/2floz) - 700cPs
- KT009999N003 Standard calibration oil (60ml/2floz) - 1000cPs
- KT009999N004 Standard calibration oil (60ml/2floz) - 25000cPs
- KT009999N005 Standard calibration oil (60ml/2floz) - 40000cPs
- KT009999N101 Standard calibration oil (500ml/1pint) - 300cPs
- KT009999N102 Standard calibration oil (500ml/1pint) - 700cPs
- KT009999N103 Standard calibration oil (500ml/1pint) - 1000cPs
- KT009999N104 Standard calibration oil (500ml/1pint) - 25000cPs
- KT009999N105 Standard calibration oil (500ml/1pint) - 40000cPs

## Elcometer ViscosityMaster™ Software

ViscosityMaster™ is the powerful, yet easy to use software supplied with all Elcometer 2300 Rotational Viscometers.

Specifically designed to maximise the versatility and usability of the viscometer, data can be stored along with associated photographs, test notes and all related test information.

There are two operating modes: manual and automatic.

In manual mode, measurements are recorded as they are taken by the instrument, but the viscometer is not controlled by the software.

In PC controlled (automatic) mode (available on -R model viscometers), measurements are recorded and the viscometer can be controlled by the software via a PC. When running a batch in automatic mode, the viscometer will start and stop under the control of ViscosityMaster™ and measurements and charts are shown in real time.

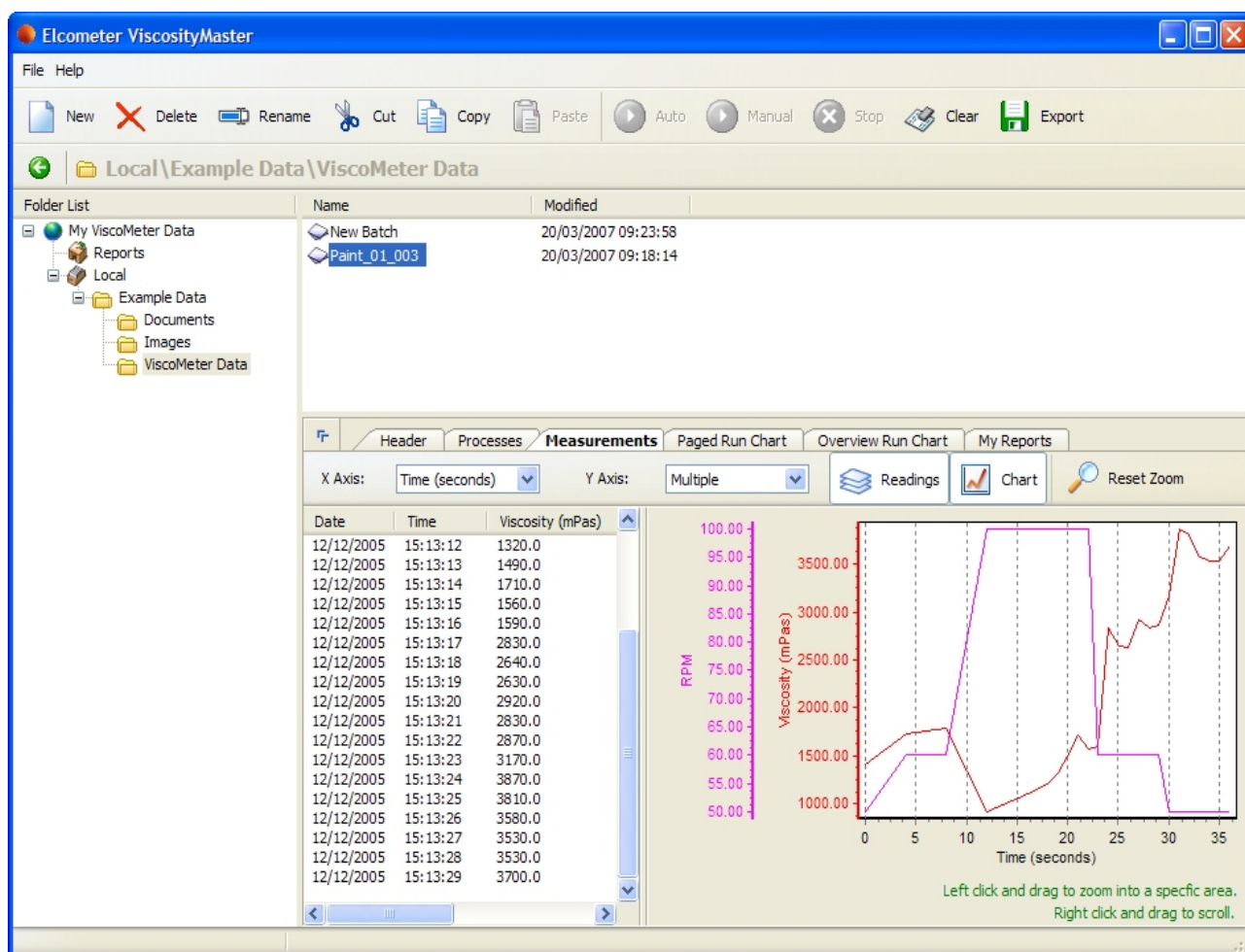

## Elcometer ViscosityMaster™ Data Management

ViscosityMaster™ makes it easy to collate and use the data recorded. Whether the data is required for analysis or to create professional reports for distribution to customers or colleagues, ViscosityMaster™ can deliver. With inbuilt report templates and easy access to all data, images and other associated files, ViscosityMaster™ makes managing data quick and easy.

The end result is a software package supplied with the Viscometer which can be fully tailored to meet specific requirements, producing detailed reports in landscape or portrait format quickly, easily and effectively.

The ViscosityMaster™ software has been designed to be familiar and intuitive to any PC user.

It is simple to batch all associated files and folders, create new batches or reports and programme the viscometer.

An example batch is pre-loaded into the software helping the user to discover all the features available.

The Process Wizard will ask the user to define process variables such as Identifier, Start RPM, End RPM, Time etc. On input of the information required, select 'Finish' and the new process will appear in the 'Processes' tab window.

Once the particular test procedure has been defined, it is simple to create as many processes as are required.

Viewing measurement data and producing standard reports is achievable in just a few clicks.

The user can zoom in on an area of the chart, view multiple batches simultaneously, view thumbnails of your report or see the report page by page.

Customising the display window makes ViscosityMaster™ even quicker to use. Viewing tabs can be added or deleted to suit the particular test methods and reporting procedures.

Custom reports are produced with report wizards and page designers. Aside from the measurements and charts, the user can include photographs, images, Word documents etc. When complete, this can be saved and exported as a PDF or a JPEG image and e-mailed as an attachment anywhere that is required.

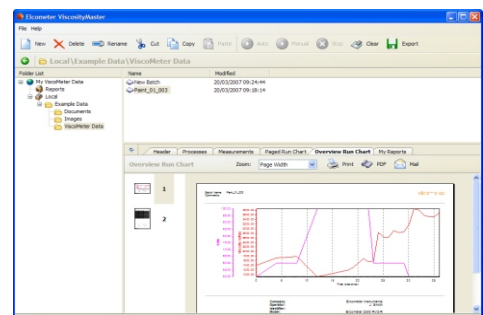
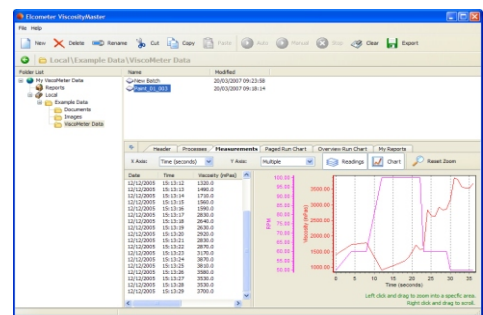
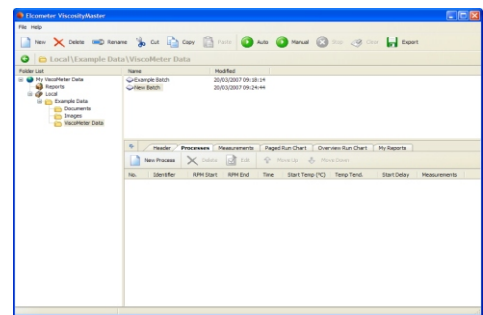
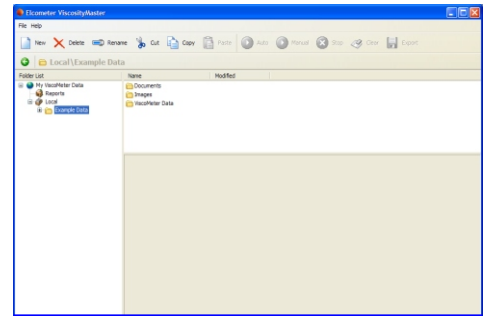

## Elcometer 2280 Matthis Fluidometer

The Elcometer 2280 is a simple and easy-to-use instrument to measure the fluidity of a coating.

The coating to be measured is poured into the semi-spherical cavity of the instrument, which is in the horizontal position. The instrument is then lifted vertically allowing the liquid in the groove to flow under gravity and is graduated in mm.

The distance flowed after approximately 10 seconds  $\pm$  0.5 seconds, measured with the sand timer provided, indicates the fluidity of the coating.

### Technical Specification

Part Number	Description
K0002280M001	Elcometer 2280 Matthis Fluidometer



## Elcometer 2290 Daniel Flow Gauge

This simple instrument is used to assess the ability of thick or paste-like materials such as paints or printing inks to flow.

The product is poured into the semi-cylindrical reservoir. When the instrument is lifted vertically, the product runs on a graduated plate, which is fixed perpendicular to the reservoir.

The distance covered in a pre-determined time is the measure of the fluidity.

### Technical Specification

Part Number	Description
K0002290M001	Elcometer 2290 Daniel Flow Gauge





## Density

To maintain consistency of a coating, the Density should remain constant from batch to batch.

Density Cups, also known as Specific Gravity Cups or Picnometers, are used to determine the mass per unit volume (Specific Gravity) of a liquid at a given temperature.

Specific Gravity is defined as the ratio of the density of a given substance to the density of water, when both are at the same temperature.

As the Specific Gravity Cup is an exact measurement of the volume of the liquid, it is imperative that the exact weight of the sample is obtained.

Elcometer offers a range of cups and laboratory balances for accurate measurements during the development of a coating.

### How to use a Density Cup:

- Weigh the Cup when empty
- Fill with the liquid
- Place lid on the Cup\*
- Weigh the Gravity Cup when full and divide the weight by the volume to determine the Specific Gravity

*\*Note that each Cup has an escape hole in the lid to allow excess liquid to escape. Any excess liquid should be removed before weighing.*

The formulae for calculating Density and Specific Gravity are:

$$\text{Density} = \frac{\text{Weight}}{\text{Unit Volume}}$$

$$\text{Specific Gravity} = \frac{\text{Density of the Material}}{\text{Density of Water at the Same Temperature}}$$



## Elcometer 1800 Density Cup

The Elcometer 1800 is a stainless steel or anodised aluminium precision cup for determining the specific gravity or density of paints and similar products.

The instrument consists of a cylindrical container and lid with a hole for the exhaust of excess liquid.

Calibration Certificates are available and should be ordered at the time of purchase of the Cup.



### Technical Specification

Part Number	Description	Capacity
K0001800M001	Elcometer 1800/1 Density Cup stainless steel	50cc
K0001800M002	Elcometer 1800/2 Density Cup stainless steel with test certificate	50cc
K0001800M003	Elcometer 1800/3 Density Cup aluminium	50cc
K0001800M004	Elcometer 1800/4 Density Cup aluminium with test certificate	50cc
K0001800M005	Elcometer 1800/5 Density Cup stainless steel	100cc
K0001800M006	Elcometer 1800/6 Density Cup stainless steel with test certificate	100cc
K0001800M007	Elcometer 1800/7 Density Cup aluminium	100cc
K0001800M008	Elcometer 1800/8 Density Cup aluminium with test certificate	100cc

*Can be used in accordance with: (see Standards Explained inside Front Cover)*

ASTM D 891-B, ASTM D 1475, DIN 53217-2:1991, FTMS 141 4183, FTMS 141 4184, ISO 2811-1, NBN T22-110, NFT 30-020

**T.A.C.** certificate available

## Elcometer 8720 KB Balance

The Elcometer 8720 KB is a compact, low cost balance which offers extensive weighing functions selectable by the user.

There are two models available in two scale ranges. The Elcometer 8720/1 and Elcometer 8720/2 Balances are very easy to use and supplied with a protective working cover and adjusting weight to allow the user to quickly adjust the calibration.



### Technical Specification

**CA** certificate available

Part Number			Description
UK 240V	EUR 220V	US 110V	
<b>K0UK8720M001</b>	<b>K0008720M001</b>	<b>K0US8720M001</b>	Elcometer 8720/1 Standard Balance
<b>K0UK8720M002</b>	<b>K0008720M002</b>	<b>K0US8720M002</b>	Elcometer 8720/2 Standard Balance
Range	Elcometer 8720/1: 0 - 1210g (0 - 42.7oz)		Elcometer 8720/2: 0 - 10100g (0 - 356.3oz)
Reproducibility	Elcometer 8720/1: 0.01g (0.0004oz)		Elcometer 8720/2: 0.1g (0.0004oz)
Linearity	Elcometer 8720/1: ±0.03g (0.001oz)		Elcometer 8720/2: ±0.3g (0.001oz)
Dimensions	165 x 230 x 80mm (6 x 9 x 3.1")		
Weight	1kg (2.2lb)		
Packing List	Elcometer 8720 KB Balance, 1 x 200g test weight, power cable and operating instructions		

### Accessories

<b>KT008720P002</b>	PC Interface Cable
---------------------	--------------------

## Elcometer 8721 Analytical Balance

The Elcometer 8721 Analytical Balance is a very stable and robust balance due to its metal casing.

Supplied with a glass draft excluder, the Elcometer 8721 is more accurate than the Elcometer 8720 and allows the user to take repeatable and accurate measurements.

Each Balance is supplied with a test weight to allow the user to quickly adjust the calibration and can be connected to a PC for digital data readings.



### Technical Specification

**C,A** certificate available

Part Number			Description
UK 240V	EUR 220V	US 110V	
<b>K0UK8721M001</b>	<b>K0008721M001</b>	<b>K0US8721M001</b>	Elcometer 8721 Analytical Balance
Range	0 - 220g		
Reproducibility	0.1mg		
Linearity	±0.2mg		
Dimensions	271 x 305 x 320mm (10 x 12 x 12.5")		
Weight	7kg (15.4lb)		
Packing List	Elcometer 8721 Analytical Balance with glass draft excluder, 1 x 200g test weight, power cable and operating instructions		

### Accessories

<b>KT008721P002</b>	PC Interface Cable
---------------------	--------------------

## Flash Point

When developing any solvent based liquid such as paint, coating, ink or perfume, it is imperative that the Flash Point is determined and declared in order to meet the stringent transport regulations laid down by governments around the world.

### **Definition:**

Flash Point is defined as “the lowest temperature of a liquid at which its vapours will form a combustible mixture with air”. It is a convenient and reliable classification of the “flammability” of many substances.

- **Open Cup tests** simulate an un-contained condition, for example a spillage.
- **Closed Cup tests** simulate an enclosed environment, for example storage in a tank or sealed container and are usually specified due to improved precision.
- **Measuring Flash Point**  
Most industries need to test the Flash Point of raw materials, products or waste to ensure:
  - Product quality* - as a measure of consistency and performance comparison
  - Compliance testing* - to test safety classification for handling, storage, transport and waste
  - In-service analysis* - tests on in-use oils and other substances for contamination/adulteration
  - General safety* - to evaluate hazard potential
  - Specifications* - to check conformance
- **Testing flammable & combustible substances for Flash Point**  
The “flammability” of a material determines its safety classification and the regulations under which it must be handled, stored and transported. As not all mixtures containing solvents are highly flammable, an accurate and rapid Flash Point check is vital in reporting a material’s “flammability” classification and may assist to save costs and reduce giveaway.
- **Flash point tests using the “rapid equilibrium” method**  
Traditional Equilibrium Flash Point tests which use any cup in a water bath, such as ISO1516 and ISO1523, ensure that the liquid and vapour of the sample are in temperature equilibrium by adopting a complex procedure and a very slow heating rate.

Elcometer Setaflash utilises a 2ml (0.067 fl oz) or 4ml (0.135 fl oz) sample which achieves rapid equilibrium and gives a reliable Flash Point result in just one or two minutes.



## Elcometer 6910/1 Setaflash 'Series 3' Closed Cup Tester

A wide range of features ensures ease of operation and requires minimum operator skill. Test parameters are set via the keypad and a digital display provides temperature, sample size, test time and flash detection status. Default 'Auto' values are available for standard test conditions.

The Elcometer 6910 Closed Cup Tester can test from ambient to 300°C (572°F). Temperature is factory calibrated but facilities for user verification and calibration are incorporated.

Flash Point is automatically detected using a thermally activated detector, reducing the risk of operator error and minimising the potential danger of inhaling fumes during a test. A rechargeable gas tank with On/Off switch and fine adjustment are integral to the unit. Supplied with a 2ml (0.067fl oz) syringe and ignitor.

To test below the ambient temperature, an optional cooling module, suitable for temperatures as low as 0°C (32°F), should be ordered.



### Technical Specification

 certificate available

Part Number	Description		
UK 240V	EUR 220V	US 110V	
<b>K0UK6910M010</b>	<b>K0006910M010</b>	<b>K0US6910M010</b>	Elcometer 6910/1 Setaflash Series 3 Closed Cup Tester
Sample Size and	2ml (0.067fl oz) for Flash Points, from ambient up to 100°C (212°F)		
Temperature Range	4ml (0.135fl oz) for Flash Points between 100°C to 300°C (212°F to 572°F)		
Test Times	Between 1 and 30 minutes (user definable)		
Default Values	1 minute for Flash Points, from ambient up to 100°C (212°F) 2 minutes for Flash Points between 100°C to 300°C (212°F to 572°F)		
Cup Material	Aluminium		
Dimensions	256 x 280 x 256mm (10.1 x 11.0 x 10.8")		
Weight	4kg (8.8lb)		
Packing List	Elcometer 6910 Setaflash 'Series 3' closed cup tester, 2ml (0.067fl oz) syringe, gas canister and ignitor, silicone rubber tubing for gas canister to gas jet connection, silicone sample well 'O' ring seal for cup/lid (red coloured), viton sample well 'O' ring seal for cup/lid (black coloured), mains power cable, automatic flash detector probe, Series 3 manuals (on CD) and operating instructions		

*Can be used in accordance with: (see Standards Explained inside Front Cover)*

**ASTM D 1655, ASTM D 3278, ASTM D 3828, ASTM E 502, BS 3900-A13, BS 3900-A14, BS 6664-3, BS 6664-4, EN 456, ISO 3679, ISO 3680**

### Accessories

**KT006910N001** Cooling Module Option for 0°C - Ambient Temperature (32°F - Ambient Temperature)

## Elcometer 6910/2 Setaflash ‘Series 3’ Open Cup Tester

The Elcometer 6910/2 Setaflash Series 3 Open Cup Tester offers the fastest and most accurate Flash Point instrument at a cost effective price.

Certain substances, classified as “flammable” by Closed Cup Flash Point Testing, may be reclassified as “non-flammable” by combustibility testing. This has significant potential cost reduction implications for the packaging, storage and shipping of many materials.

The Elcometer 6910 Setaflash features an open cup for flash/no-flash finite determinations or sustained combustion tests, audible and on-screen prompts and easy calibration. Flash Point tests can be conducted in less than two minutes with a temperature range from ambient to 300°C (572°F)

A manually operated flame sweeping arm is fitted to the cup and gas is supplied from the integral tank via the control valve. The flash or sustained combustion characteristics of the sample are observed visually by passing the test flame over the sample.



### Technical Specification

**C** certificate available

Part Number	Description	
UK 240V	EUR 220V	US 110V
<b>K0UK6910M011</b>	<b>K0006910M011</b>	<b>K0US6910M011</b>
Sample Size and	Elcometer 6910/2 Setaflash Series 3 Open Cup Tester	
Temperature Range	2ml (0.067fl oz) for Flash Points, from ambient up to 100°C (212°F)	
Test Time	4ml (0.135fl oz) for Flash Points between 100°C to 300°C (212°F to 572°F)	
Default Values	1 to 99 minutes	
Cup Material	1 minute for Flash Points up to 100°C (212°F)	
Dimensions	2 minutes for Flash Points between 100°C to 300°C (212°F to 572°F)	
Weight	Aluminium	
Packing List	256 x 280 x 256mm (10 x 11 x 10.8")	
	4kg (8.8lb)	
	Elcometer 6910 Setaflash ‘Series 3’ open cup tester, 2ml (0.067fl oz) syringe, gas canister and ignitor, silicone rubber tubing for gas canister to gas jet connection, silicone sample well ‘O’ ring seal for cup/lid (red coloured), viton sample well ‘O’ ring seal for cup/lid (black coloured), mains power cable, automatic flash detector probe, Series 3 manuals (on CD) and operating instructions	

Can be used in accordance with: (see Standards Explained inside Front Cover)

ASTM D 4206, BS 3900-A11, ISO 9038

## Elcometer 6910/3 Setaflash Series 3 Active-Cool

The Setaflash Series 3 Active-Cool Tester offers the same features as the Elcometer 6910/1 Setaflash but is fitted with a cup suitable for testing corrosive samples.

It has been designed to carry out Flash/No Flash tests rapidly and efficiently to determine the Flash Point of liquids and semi-solids in the 10°C to 130°C (50°F to 266°F) temperature range.

Flash Point is automatically detected using a thermally activated detector, reducing the risk of operator error and minimising the potential danger of inhaling fumes during a test. A rechargeable gas tank with On/Off switch and fine adjustment are integral to the unit. Supplied with a 2ml (0.067fl oz) syringe and ignitor.

### Features:

- Flash Point test in less than 2 minutes
- Small sample size - 2ml (0.067 fl oz) or 4ml (0.135 fl oz)
- Electronic Peltier cooling effect
- °C or °F display



### Technical Specification



Part Number	Description	
	UK 240V	EUR 220V      US 110V
<b>K0UK6910M013</b>	<b>K0006910M013</b>	<b>K0US6910M013</b> Elcometer 6910/3 Setaflash Series 3 Active-Cool
Sample Size and Temperature Range	2ml (0.067fl oz) for Flash Points up to 100°C (212°F) 4ml (0.135fl oz) for Flash Points between 100°C to 300°C (212°F to 572°F)	
Test Time	1 to 99 minutes	
Default Values	1 minute for flash points up to 100°C (212°F) 2 minutes for flash points between 100°C to 300°C (212°F to 572°F)	
Cup Material	Corrosion resistant steel	
Dimensions	256 x 280 x 256mm (10.1 x 11.0 x 10.8")	
Weight	5kg (11.3lb)	
Packing List	Elcometer 6910 Setaflash Series 3 active-cool closed cup tester, 2ml (0.067fl oz) syringe, gas canister and ignitor, silicone rubber tubing for gas canister to gas jet connection, silicone sample well 'O' ring seal for cup/lid (red coloured), viton sample well 'O' ring seal for cup/lid (black coloured), mains power cable, automatic flash detector probe, Series 3 manuals (on CD) and operating instructions	

*Can be used in accordance with: (see Standards Explained inside Front Cover)*

**ASTM D 1655, ASTM D 3278, ASTM D 3828, ASTM E 502, BS 3900-A13, BS 3900-A14, BS 6664-3, BS 6664-4, EN 456, ISO 3679, ISO 3680, UN Class 3 non-viscous flammable liquids**



## Film Application & Test Charts

For numerous products, such as paint, ink, varnishes, glue and cosmetics, the reliability of many laboratory tests is directly related to the quality and consistency of the samples. To ensure repeatability and reproducibility, any measurements made on such coatings, whether for the purpose of describing their physical properties (drying time, elasticity, abrasion etc.) or their appearance, (gloss, colour, shade, etc.) are made on the basis of uniform and comparable samples with precisely controlled thickness.

In order to meet such specific demands, Elcometer has a wide range of high precision film applicators and spiral bar coaters for greater repeatability and reproducibility when undertaking a large number of sample tests.

For the greatest repeatability and reproducibility, manual application is not sufficient as speed and smoothness of flow are also critical factors.

Elcometer's range of Motorised Film Applicators has been designed specifically to ensure:

- constant speed
- smoothness of operation - ensuring no jerks which create ridges and variation in thickness
- repeatability and reproducibility every time

Available with a highly engineered table, available with or without a vacuum and heating element, each Elcometer Motorised Film Applicator is accurately measured using a Co-ordinate Measuring Machine to meet an incredibly high level of flatness. (Vacuum tables offer more reproducibility).

The average variation on Elcometer Application Tables is  $2.3\mu\text{m}$  (0.092mil), while the average variation on glass used on some low cost tables is  $12.0\mu\text{m}$  (0.48mil).

If a  $100\mu\text{m}$  (4mils) coating is tested, readings taken using an Elcometer table would produce readings between 97.7 (3.9mils) and  $102.3\mu\text{m}$  (4.1mils). On glass, the readings produced would be between 88 (3.5mils) and  $112\mu\text{m}$  (4.48mils) - **a 47% variation.**

Elcometer also offers a wide range of Leneta Test Charts to meet all specific requirements, which feature a combination of black and white markings. These are the two extremes of colour thereby indicating the thickness of coating required to cover the whole colour spectrum.

This range of Leneta Test Chart covers a variety of testing needs including the hiding power of coatings, ink qualities, penetration, spreading rates and opacity.



## Elcometer 4360/4361 Spiral Bar Coaters

Made of stainless steel and consisting of a cylindrical bar wound with stainless steel wire, these spiral bar coaters are used to apply a pre-determined thickness for coatings with high levelling characteristics.

- A wide range of different wire diameters provides a range of measures for coating thicknesses from 4 to 500µm (0.157 to 19.685mils).
- 2 standard bar widths are available, 140mm (5.5") or 250mm (9.8"), allowing the user to apply the correct film width dependent on the substrate or test chart width. Other widths are available on request.

Ideal for use with the Elcometer 4340 Motorised Film Applicators; please see pages 52 - 54.

A range of standard and heated vacuum tables is available; see page 51 for more information.



### Technical Specification

Bar Width 140mm (5.5")				Bar Width 140mm (5.5")			
Part Number	Model	Coating Thickness		Part Number	Model	Coating Thickness	
		µm	mils			µm	mils
K0004361P001	Elcometer 4361/1	4	0.157	K0004361P017	Elcometer 4361/17	66	2.598
K0004361P002	Elcometer 4361/2	6	0.236	K0004361P018	Elcometer 4361/18	70	2.755
K0004361P003	Elcometer 4361/3	8	0.315	K0004361P019	Elcometer 4361/19	76	2.992
K0004361P004	Elcometer 4361/4	10	0.393	K0004361P020	Elcometer 4361/20	80	3.149
K0004361P005	Elcometer 4361/5	12	0.472	K0004361P021	Elcometer 4361/21	90	3.543
K0004361P006	Elcometer 4361/6	16	0.630	K0004361P022	Elcometer 4361/22	100	3.937
K0004361P007	Elcometer 4361/7	20	0.787	K0004361P023	Elcometer 4361/23	110	4.330
K0004361P008	Elcometer 4361/8	26	1.024	K0004361P024	Elcometer 4361/24	120	4.724
K0004361P009	Elcometer 4361/9	30	1.181	K0004361P025	Elcometer 4361/25	130	5.118
K0004361P010	Elcometer 4361/10	34	1.338	K0004361P026	Elcometer 4361/26	140	5.511
K0004361P011	Elcometer 4361/11	38	1.496	K0004361P027	Elcometer 4361/27	150	5.905
K0004361P012	Elcometer 4361/12	40	1.574	K0004361P029	Elcometer 4361/29	175	6.890
K0004361P013	Elcometer 4361/13	46	1.811	K0004361P030	Elcometer 4361/30	200	7.874
K0004361P014	Elcometer 4361/14	50	1.968	K0004361P031	Elcometer 4361/31	300	11.811
K0004361P015	Elcometer 4361/15	56	2.205	K0004361P032	Elcometer 4361/32	400	15.748
K0004361P016	Elcometer 4361/16	60	2.362	K0004361P033	Elcometer 4361/33	500	19.685

### Technical Specification

#### Bar Width 250mm (9.8")

Part Number	Model	Coating µm	Thickness mils
K0004360P001	Elcometer 4360/1	4	0.157
K0004360P002	Elcometer 4360/2	6	0.236
K0004360P003	Elcometer 4360/3	8	0.315
K0004360P004	Elcometer 4360/4	10	0.393
K0004360P005	Elcometer 4360/5	12	0.472
K0004360P006	Elcometer 4360/6	16	0.630
K0004360P007	Elcometer 4360/7	20	0.787
K0004360P008	Elcometer 4360/8	26	1.024
K0004360P009	Elcometer 4360/9	30	1.181
K0004360P010	Elcometer 4360/10	34	1.338
K0004360P011	Elcometer 4360/11	38	1.496
K0004360P012	Elcometer 4360/12	40	1.574
K0004360P013	Elcometer 4360/13	46	1.811
K0004360P014	Elcometer 4360/14	50	1.968
K0004360P015	Elcometer 4360/15	56	2.205
K0004360P016	Elcometer 4360/16	60	2.362

#### Bar Width 250mm (9.8")

Part Number	Model	Coating µm	Thickness mils
K0004360P017	Elcometer 4360/17	66	2.598
K0004360P018	Elcometer 4360/18	70	2.755
K0004360P019	Elcometer 4360/19	76	2.992
K0004360P020	Elcometer 4360/20	80	3.149
K0004360P021	Elcometer 4360/21	90	3.543
K0004360P022	Elcometer 4360/22	100	3.937
K0004360P023	Elcometer 4360/23	110	4.330
K0004360P024	Elcometer 4360/24	120	4.724
K0004360P025	Elcometer 4360/25	130	5.118
K0004360P026	Elcometer 4360/26	140	5.511
K0004360P027	Elcometer 4360/27	150	5.905
K0004360P029	Elcometer 4360/29	175	6.890
K0004360P030	Elcometer 4360/30	200	7.874
K0004360P031	Elcometer 4360/31	300	11.811
K0004360P032	Elcometer 4360/32	400	15.748
K0004360P033	Elcometer 4360/33	500	19.685

Can be used in accordance with: (see Standards Explained inside Front Cover)

ASTM D 4147

Customers who purchased the Elcometer 4360 also purchased:



◀ Elcometer 4695 Leneta  
Charts, page 55 - 64

Elcometer 4340 Motorised  
Film Applicator, page 52 - 54 ▶



## Elcometer 3520 Baker Film Applicator

Made of hardened stainless steel with a cylindrical applicator body, these gauges apply a coating of specified thickness and film width on flat, relatively firm substrates.

The Elcometer 3520 Baker Film Applicator can also be used with the Elcometer 4340 Motorised Film Applicators (see pages 52 - 54).

Each Elcometer 3520 Baker Film Applicator has four high precision specified coating thickness sizes for accuracy and is available in a range of film widths.

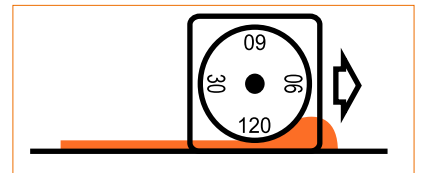
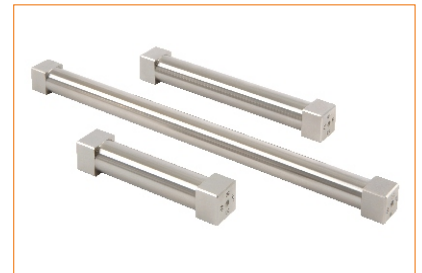

### Technical Specification

certificate available

Part Number		Model	Film Thickness		Film Width	
Metric	Imperial		µm	mils	mm	inches
K0003520M001	K0US3520M001	Elcometer 3520/1	30, 60, 90, 120	1, 2, 3, 4	25	1
K0003520M002	K0US3520M002	Elcometer 3520/2	30, 60, 90, 120	1, 2, 3, 4	50	2
K0003520M003	K0US3520M003	Elcometer 3520/3	30, 60, 90, 120	1, 2, 3, 4	60	2.5
K0003520M101	K0US3520M101	Elcometer 3520/101	50, 100, 150, 200	2, 4, 6, 8	60	2.5
K0003520M004	K0US3520M004	Elcometer 3520/4	30, 60, 90, 120	1, 2, 3, 4	75	3
K0003520M005	K0US3520M005	Elcometer 3520/5	30, 60, 90, 120	1, 2, 3, 4	100	4
K0003520M006	K0US3520M006	Elcometer 3520/6	30, 60, 90, 120	1, 2, 3, 4	125	5
K0003520M007	K0US3520M007	Elcometer 3520/7	30, 60, 90, 120	1, 2, 3, 4	150	6
K0003520M011	K0US3520M011	Elcometer 3520/11	30, 60, 90, 120	1, 2, 3, 4	175	7
K0003520M008	K0US3520M008	Elcometer 3520/8	30, 60, 90, 120	1, 2, 3, 4	200	8
K0003520M009	K0US3520M009	Elcometer 3520/9	30, 60, 90, 120	1, 2, 3, 4	250	10

Can be used in accordance with: (see Standards Explained inside Front Cover)

ASTM D 823-E

## Elcometer 3525 & 3530 Adjustable Baker Film

The Elcometer 3525 & 3530 are manufactured using the very latest machining techniques to ensure outstanding accuracy. These Baker Film Applicators allow the user to select the specific gap size required. The coating thickness gap size can be set to produce either a uniform film or a film wedge. Each film applicator has thickness markings down each side for fast set up.

Available in two gap size ranges and a number of film widths, these stainless steel applicators can be used manually or with the Elcometer 4340 Motorised Film Applicator (see pages 52 - 54).

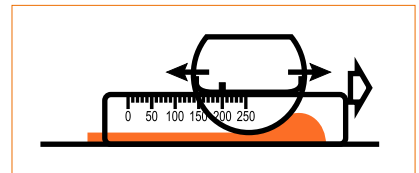
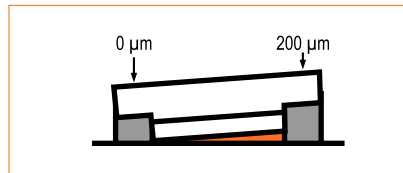

### Technical Specification

**C** certificate available

Part Number		Model	Film Thickness		Film Width	
Metric	Imperial		µm	mils	mm	inches
K0003525M001	K0US3525M001	Elcometer 3525/1	0 - 100	0 - 4	50	2
K0003525M002	K0US3525M002	Elcometer 3525/2	0 - 100	0 - 4	75	3
K0003525M003	K0US3525M003	Elcometer 3525/3	0 - 100	0 - 4	100	4
K0003525M004	K0US3525M004	Elcometer 3525/4	0 - 100	0 - 4	150	6
K0003525M005	K0US3525M005	Elcometer 3525/5	0 - 100	0 - 4	200	8
K0003525M006	K0US3525M006	Elcometer 3525/6	0 - 100	0 - 4	250	10
K0003530M001	K0US3530M001	Elcometer 3530/1	0 - 250	0 - 10	50	2
K0003530M002	K0US3525M002	Elcometer 3530/2	0 - 250	0 - 10	75	3
K0003530M003	K0US3525M003	Elcometer 3530/3	0 - 250	0 - 10	100	4
K0003530M004	K0US3525M004	Elcometer 3530/4	0 - 250	0 - 10	150	6
K0003530M005	K0US3525M005	Elcometer 3530/5	0 - 250	0 - 10	200	8
K0003530M006	K0US3525M006	Elcometer 3530/6	0 - 250	0 - 10	250	10

Can be used in accordance with: (see Standards Explained inside Front Cover)

ASTM D 823-E

## Elcometer 3550 & 3540 Bird Film Applicators

These easy to clean gauges are manufactured to the highest accuracy.

Precision ground stainless steel Bird Film Applicators have a flat edged prismatic body making them suitable for coatings applied to a flat and relatively strong substrate.

The Elcometer 3550 Bird Film Applicator has 1 film thickness, whereas the Elcometer 3540 has 4 thicknesses per applicator.

Both versions are available in a range of film widths and can be used with the Elcometer 4340 Motorised Film Applicators (see pages 52 - 54).

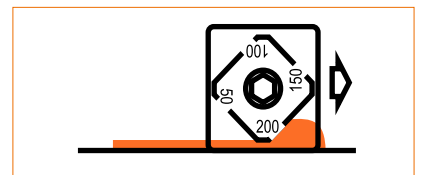
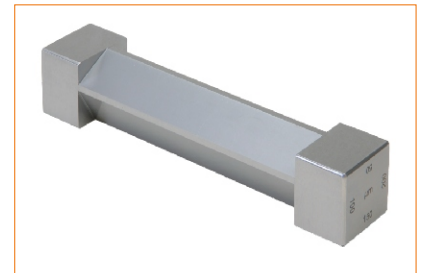

### Technical Specification

**CA** certificate available

Part Number		Model	Film Thickness		Film Width	
Metric	Imperial		µm	mils	mm	inches
K0003550M001	K0US3550M001	Elcometer 3550/1	50	2	50	2
K0003550M002	K0US3550M002	Elcometer 3550/2	50	2	75	3
K0003550M003	K0US3550M003	Elcometer 3550/3	50	2	150	6
K0003550M201	K0US3525M201	Elcometer 3550/1	75	3	50	2
K0003550M202	K0US3525M202	Elcometer 3550/2	75	3	75	3
K0003550M203	K0US3525M203	Elcometer 3550/3	75	3	150	6
K0003540M001	K0US3540M001	Elcometer 3540/1	50, 100, 150, 200	2, 4, 6, 8	50	2
K0003540M002	K0US3540M002	Elcometer 3540/2	50, 100, 150, 200	2, 4, 6, 8	75	3
K0003540M003	K0US3540M003	Elcometer 3540/3	50, 100, 150, 200	2, 4, 6, 8	100	4
K0003540M004	K0US3540M004	Elcometer 3540/4	50, 100, 150, 200	2, 4, 6, 8	150	6
K0003540M005	K0US3540M005	Elcometer 3540/5	50, 100, 150, 200	2, 4, 6, 8	200	8
K0003540M006	K0US3540M006	Elcometer 3540/6	50, 100, 150, 200	2, 4, 6, 8	250	10

Can be used in accordance with: (see Standards Explained inside Front Cover)

ASTM D 823-E

## Elcometer 3545 Adjustable Bird Film Applicators

Manufactured to the same high standards as the Elcometer 3540 and 3550 Bird Film Applicators, Elcometer 3545 Adjustable Bird Film Applicators are user adjustable.

By choosing different settings each end (using the gap size scale), a wedge shaped film can be applied.

Available in a number of film widths, these high precision applicators can be used manually or with the Elcometer 4340 Motorised Film Applicators (see pages 52 - 54).



### Technical Specification

certificate available

Part Number		Model	Film Thickness		Film Width	
Metric	Imperial		µm	mils	mm	inches
K0003545M201	K0US3545M201	Elcometer 3545/1	0 - 250	0 - 10	50	2
K0003545M002	K0US3545M002	Elcometer 3545/2	0 - 250	0 - 10	75	3
K0003545M203	K0US3545M203	Elcometer 3545/3	0 - 250	0 - 10	100	4
K0003545M004	K0US3545M004	Elcometer 3545/4	0 - 250	0 - 10	125	5
K0003545M005	K0US3545M005	Elcometer 3545/5	0 - 250	0 - 10	150	6
K0003545M006	K0US3545M006	Elcometer 3545/6	0 - 250	0 - 10	175	7
K0003545M007	K0US3545M007	Elcometer 3545/7	0 - 250	0 - 10	200	8
K0003545M008	K0US3545M008	Elcometer 3545/8	0 - 250	0 - 10	250	10

Can be used in accordance with: (see Standards Explained inside Front Cover)

ASTM D 823-E

## Elcometer 3570 Micrometric Film Applicators

The Elcometer 3570 is made of anodised aluminium with a reservoir and a bevelled blade applicator body, and is suitable for high-precision manual application of high viscosity fluids onto relatively firm substrates.

The gap can be adjusted, in 1micron intervals, from 0 to 1mm by the inclination of the device, using a micrometric screw.



### Technical Specification

certificate available

Part Number	Description	Film Thickness	Film Width	
		µm	mm	inches
	Elcometer 3570/1 Micrometric Film Applicator	0 - 1000	75	3
K0003570M201	Elcometer 3570/2 Micrometric Film Applicator	0 - 1000	100	4
K0003570M002	Elcometer 3570/3 Micrometric Film Applicator	0 - 1000	150	6
K0003570M003	Elcometer 3570/4 Micrometric Film Applicator	0 - 1000	200	8

Can be used in accordance with: (see Standards Explained inside Front Cover)

ASTM D 823-E

## Elcometer 3580 Casting Knife Film Applicator

The Elcometer 3580 is available in a wide range of film widths and has extended sides to confine the coating during the application and is an ideal gauge for the laboratory.

The film thickness can be adjusted in 10 micron steps from 0 to 6mm by means of two integrated micrometric screws.

Manufactured in anodised aluminium, with a bevelled blade applicator body, the Elcometer 3580 is recommended for manually applying thick, high viscosity fluids, on solid and flat substrates.

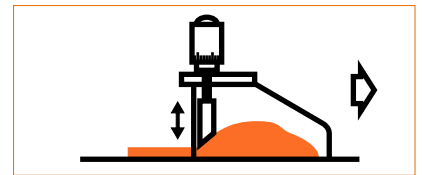

### Technical Specification

certificate available

Part Number	Description	Film Thickness µm	Film Width	
			mm	inches
K0003580M201	Elcometer 3580/1 Casting Knife Film Applicator	0 - 6000	50	2
K0003580M202	Elcometer 3580/2 Casting Knife Film Applicator	0 - 6000	75	3
K0003580M203	Elcometer 3580/3 Casting Knife Film Applicator	0 - 6000	100	4
K0003580M204	Elcometer 3580/4 Casting Knife Film Applicator	0 - 6000	125	5
K0003580M005	Elcometer 3580/5 Casting Knife Film Applicator	0 - 6000	150	6
K0003580M006	Elcometer 3580/6 Casting Knife Film Applicator	0 - 6000	175	7
K0003580M007	Elcometer 3580/7 Casting Knife Film Applicator	0 - 6000	200	8

Can be used in accordance with: (see Standards Explained inside Front Cover)  
**ASTM D 823-E**

Also available in Stainless Steel - Contact Elcometer for further information



## Elcometer 3600 Doctor Blade Film Applicator

Made of hardened stainless steel with a flat-edge bevelled blade applicator body, this adjustable applicator is suitable for various products applied on flat and relatively firm surfaces.

It is supplied with a set of nineteen thickness gauges from 30 to 1000µm to allow the accurate setting of the gap by vertical adjustment of the scraper. A combination of thickness gauges may be combined to give up to 3000µm thickness.

The Elcometer 3600 Doctor Blade Film Applicator has a maximum gap size of 3mm and is available in a range of film widths.

Elcometer Doctor Blade Film Applicators can be used with the Elcometer 4340 Motorised Film Applicators and is available in 4 spreading values; see pages 52 - 54.

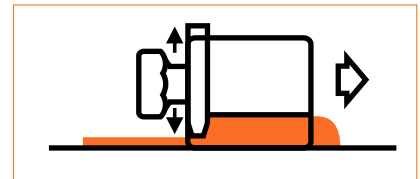

### Technical Specification

**C** certificate available

Part Number		Description	Film Thickness		Film Width	
Metric	Imperial		µm	mils	mm	inches
K0003600M201	K0US3600M201	Elcometer 3600/1 Doctor Blade Applicator	30 - 3000	1 - 120	50	2
K0003600M002	K0US3600M002	Elcometer 3600/2 Doctor Blade Applicator	30 - 3000	1 - 120	75	3
K0003600M203	K0US3600M203	Elcometer 3600/3 Doctor Blade Applicator	30 - 3000	1 - 120	100	4
K0003600M204	K0US3600M204	Elcometer 3600/4 Doctor Blade Applicator	30 - 3000	1 - 120	150	6
K0003600M205	K0US3600M205	Elcometer 3600/5 Doctor Blade Applicator	30 - 3000	1 - 120	200	8
K0003600M206	K0US3600M206	Elcometer 3600/6 Doctor Blade Applicator	30 - 3000	1 - 120	225	9

Can be used in accordance with: (see Standards Explained inside Front Cover)

ASTM D 823-E

### Accessories

KT003600P001	19 Metric Thickness Gauges for Calibration (30-40-50-60-70-80-90-100-150-200-250-300-400-500-600-700-800-900-1000µm)
--------------	---

## Elcometer 3700 Doctor Blade Film Applicators with

Made of hardened stainless steel with a flat edge bevelled blade applicator body, the Elcometer 3700 is suitable for gelatine or other products with low viscosity.

The product is applied on flat and relatively firm surfaces in a range of film widths and is supplied with a set of nineteen thickness gauges from 30 to 1000µm to accurately set the gap by vertical adjustment of the scraper.

A combination of thickness gauges may be combined to give up to 4000µm thickness.

The Elcometer 3700 can also be used with the Elcometer 4340 Motorised Automatic Film Applicators, see pages 52 - 54. It is available with four spreading values, see the Elcometer 3560 on page 47.

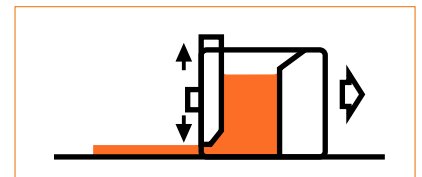

### Technical Specification

certificate available

Part Number		Description	Film Thickness		Film Width	
Metric	Imperial		µm	mils	mm	inches
K0003700M203	K0US3700M203	Doctor Blade Film Applicator with Reservoir	30 - 4000	0 - 160	80	4
K0003700M002	K0US3700M002	Doctor Blade Film Applicator with Reservoir	30 - 4000	0 - 160	180	8
K0003700M001	K0US3700M001	Doctor Blade Film Applicator with Reservoir	30 - 4000	0 - 160	250	10

Can be used in accordance with: (see Standards Explained inside Front Cover)

ASTM D 823-E

### Accessories

KT003600P001	19 Metric Thickness Gauges for Calibration (30-40-50-60-70-80-90-100-150-200-250-300-400-500-600-700-800-900-1000µm)
--------------	---

## Elcometer 3505 Cube Film Applicator

Made of hardened stainless steel with a bevelled flat-edged blade, this applicator applies film 12mm (0.5") wide, generally on any flat surface and especially on glass for evaluation of drying time.

A set of five reservoirs applies up to 5 stripes of film at the same time is also available. Ideal for simultaneously studying several different products.

Supplied with a set of nineteen thickness gauges from 30 to 1000µm to adjust the gap of the spreader blade.



### Technical Specification

**C** certificate available

Part Number		Model	Film Thickness		Film Width		Number of Stripes
Metric	Imperial		µm	mils	mm	inches	
K0003505M001	K0US3505M001	Elcometer 3505/1	30 - 1000	1 - 40	12	0.50	1
K0003505M202	K0US3505M202	Elcometer 3505/2	30 - 1000	1 - 40	12	0.50	5

Can be used in accordance with: (see Standards Explained inside Front Cover)  
**ASTM D 823-E**

### Accessories

<b>KT003600P001</b>	19 Metric Thickness Gauges for Calibration (30-40-50-60-70-80-90-100-150-200-250-300-400-500-600-700-800-900-1000µm)
---------------------	---

## Elcometer 3508 & 3560 4 Gap Applicator with Reservoir

The Elcometer 3560 is a simple gauge with a single reservoir allowing the user to generate 4 different thicknesses of coating.

The stainless steel applicator is made with 4 straight spreading edges of fixed film gaps.

The Elcometer 3508 4 Gap Applicator with 2 reservoirs has been designed specifically for the generation of test samples for use with the Elcometer 1720 Abrasion, Scrubbing and Washability Tester, see pages 70 - 74.



### Technical Specification

**C,A** certificate available

Part Number		Model	Film Thickness		Film Width	
Metric	Imperial		µm	mils	mm	inches
K0003560M201	K0US3560M201	Elcometer 3560/1	30, 60, 90, 120	1, 2, 3, 4	60	2
K0003560M202	K0US3560M202	Elcometer 3560/2	50, 100, 150, 200	2, 4, 6, 8	60	2
K0003508M001	K0US3508M001	Elcometer 3508/1	100, 150, 200,	4, 6, 8, 10	2 x 50	2 x 2

Can be used in accordance with: (see Standards Explained inside Front Cover)  
**ASTM D 823-E**

## Elcometer 3800 & 3805 Multiple Film Doctor Blade Applicators

Both the Elcometer 3800 & 3805 are made of anodised aluminium, ideal for applying 2 or 3 stripes of film side by side on a contrast chart, which slides manually between the film applicator filled with the product and its support, between 2 side guides.

Supplied with a set of nineteen gauges either from 30 to 1000µm or 1 to 40 mils to adjust the gap of the spreader blade and a pack of 100 varnished contrast charts measuring 210 x 75mm (8.25 x 3").

2 models are available: applicator with 2 reservoirs or applicator with 3 reservoirs.

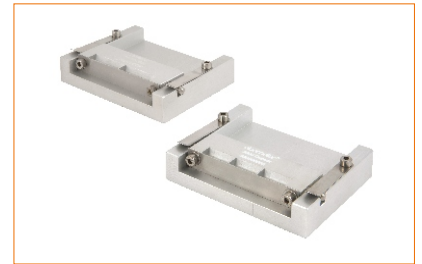

### Technical Specification

certificate available

Part Number		Model	Film Thickness		Film Width		Number of Stripes
Metric	Imperial		µm	mils	mm	inches	
K0003800M001	K0US3800M001	Elcometer 3800/1	30 - 1000	1 - 40	28	1	2
K0003805M001	K0US3805M001	Elcometer 3805/1	30 - 1000	1 - 40	18	0.70	3

*Can be used in accordance with: (see Standards Explained inside Front Cover)*

**ASTM D 823-E**

### Accessories

<b>KT003600P001</b>	19 Metric Thickness Gauges for Calibration (30-40-50-60-70-80-90-100-150-200-250-300-400-500-600-700-800-900-1000µm)
---------------------	---

Customers who purchased the Elcometer 3805 also purchased:



◀ Elcometer 5100 Payne Permability Cups, page 68

Elcometer 5300 Drying Time Recorder, page 67 ▶



## Elcometer 4260 NYPC Levelling Tester

Made from stainless steel with a straight scraper fitted with 5 pairs of notches of increasing depth from 25µm to 4.06mm (1 to 160mils), the Elcometer 4260 NYPC Levelling Tester is used to determine a coating's ability to level before curing.

Once the drawdown has been made on a horizontal firm surface, the coating is left to cure. Once dry, the thickness at which the pair of film stripes merge can be seen, identifying the minimum thickness of coating required to achieve a consistent film.



### Technical Specification

**C,A** certificate available

Part Number		Description
Metric	Imperial	
K0004260M201	K0US4260M201	Elcometer 4260 NYPC Levelling Tester
<i>Can be used in accordance with: (see Standards Explained inside Front Cover)</i>		
ASTM D 2800, <b>ASTM D 2801</b>		

## Elcometer 4270 Sag Tester

Made from stainless steel, the straight scraper has 10 notches of increasing clearance. The Elcometer 4270 Sag Tester is used to establish a coating's resistance to sag due to gravity.

A contrast chart is immediately placed in a vertical position with the thinnest film at the top. The thickness at which the stripes join indicates the tendency to sag.



### Technical Specification

**C,A** certificate available

Part Number		Description	Range	
Metric	Imperial		µm	mils
K0004270M001	K0US4270M001	Elcometer 4270/1 Sag Tester	75 - 300	3 - 12
K0004270M002	K0US4270M002	Elcometer 4270/2 Sag Tester	25 - 150	1 - 6
K0004270M203	K0US4270M203	Elcometer 4270/3 Sag Tester	350 - 1500	14 - 60
K0004270M204	K0US4270M204	Elcometer 4270/4 Sag Tester	100 - 600	4 - 24
<i>Can be used in accordance with: (see Standards Explained inside Front Cover)</i>				
ASTM D 2800, <b>FMTS 141A Method 4494</b>				

## Elcometer 4280 NYPC Levelling and Sag Tester

The Elcometer 4280 combines the Elcometer 4260 NYPC Levelling Test with the Sag Test of the Elcometer 4270.

This dual gauge is used to assess a coating's levelling characteristics and its resistance to sag due to gravity.

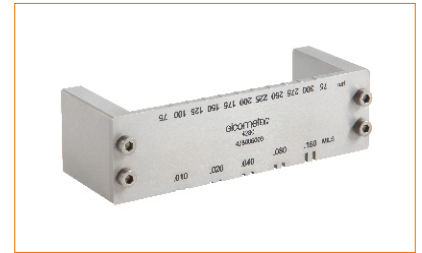

### Technical Specification

**C,A** certificate available

Part Number		Description	Range	
Metric	Imperial		µm	mils
<b>K0004280M001</b>	<b>K0US4280M001</b>	Elcometer 4280 NYPC Levelling and Sag Tester	75 - 300	3 - 12
<i>Can be used in accordance with: (see Standards Explained inside Front Cover)</i>				
ASTM D 2800, <b>ASTM D 2801</b> , <b>FMTS 141A Method 4494</b>				

## Elcometer 4290 Sag Quadruplex Film Applicator

The stainless steel film applicator has 4 spreading edges in the form of a straight scraper with 4, 6 or 10 adjacent notches (depending on the model) of varying depth.

Simultaneously applying several stripes of film of increasing thickness, the Elcometer 4290 Sag Quadruplex Film Applicator is ideal for determining the opacity or hiding power of a coating.



### Technical Specification

**C,A** certificate available

Part Number		Description	Number of Apertures	Apertures between	
Metric	Imperial			µm	mils
<b>K0004290M001</b>	<b>K0US4290M001</b>	Elcometer 4290/1 Sag Quadruplex Applicator	16	25 - 450	1 - 18
<b>K0004290M003</b>	<b>K0US4290M003</b>	Elcometer 4290/3 Sag Quadruplex Applicator	24	10 - 400	0.4 - 16
<b>K0004290M002</b>	<b>K0US4290M002</b>	Elcometer 4290/2 Sag Quadruplex Applicator	40	10 - 500	0.4 - 20
<i>Can be used in accordance with: (see Standards Explained inside Front Cover)</i>					
ASTM D 2800, <b>ASTM D 2801</b> , <b>FMTS 141A Method 4494</b>					

## Elcometer 4800 & 4900 Free Standing Vacuum Tables

Elcometer offers a comprehensive range of vacuum tables to provide an ideal surface for manual application of films on test charts or samples and is available in two formats:

- The Elcometer 4800 - this aluminium table with a channel around the edge holds flexible test pieces, e.g test charts, plastic film and paper, absolutely flat (2.3µm variation over a 100mm length).
- The Elcometer 4900 - made of perforated aluminium, keeps a wider range of test pieces absolutely flat (2.3µm variation over a 100mm length), including glass, plastic sheets, contrast charts etc.

*The perforated version is suitable for thicker, more substantial test pieces.  
The channel version is suitable for thinner materials such as plastics and films which may distort under the perforated version method.*

All beds are engineered to be flat and precise with little variation for “perfect” flatness. Both Elcometer standard tables, channelled and perforated vacuum tables are 5 times flatter than glass.

Perforated tables have two sample size settings, 210 x 297mm (8.3" x 11.7") and 297 x 420mm (11.7" x 16.6"), selected by means of a switch on the table.



### Technical Specification

Part Number	Description	Table Dimensions	
		mm	inches
K0004800M001	Channelled Vacuum Table	145 x 250	6 x 10
K0004800M002	Channelled Vacuum Table	220 x 300	8.5 x 12
K0004900M001	Perforated Vacuum Table	220 x 300	8.5 x 12
K0004900M002	Perforated Vacuum Table	300 x 450	12 x 18

### Accessories

KTUK4930M001	Vacuum Pump (UK 240V) - used to provide vacuum to the Vacuum Tables
KT004930M001	Vacuum Pump (EUR 220V) - used to provide vacuum to the Vacuum Tables
KTUS4930M001	Vacuum Pump (US 110V) - used to provide vacuum to the Vacuum Tables

## Elcometer 4340 Motorised/Automatic Film Applicator

An essential machine for preparing a wide variety of product samples including paint, varnish, cosmetics, glue, etc, with total consistency and reproducibility on various substrates including contrast charts, sheet steel, plastic foils and glass. All Elcometer 4340 models have 11 pre-set speeds and adjustable stroke length with quick release system.

Ideal for testing paint, varnish, cosmetics, glue etc.

11 preset transverse speeds from 0.5 - 10cm per second

Sample temperature control option



High quality samples produced for highly reliable laboratory testing

Can be used with Elcometer Film Applicators

Smooth aluminium table - much smoother than glass - for better repeatability



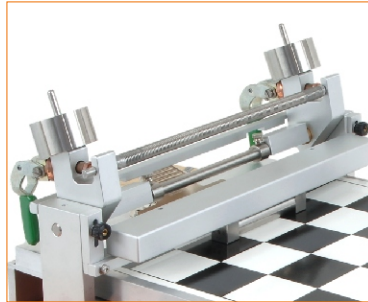

**Interchangeable head attachments**

- Easily switched between film applicators
- Spiral Bar Head Attachment
  - Standard Applicator Head Attachment
  - Combined Spiral/Standard Head Attachment



**Durable & Rugged**

- Sturdy rigid design to ensure minimal movement during film application
- Up to 15 years of standard use

Wide range of standard and high precision perforated and channelled vacuum tables



**Choice of Bed**

- Standard flat table
- Single channel vacuum table
- Double channel vacuum table
- Perforated

Adjustable travel carriage with 'stop' at end of travel

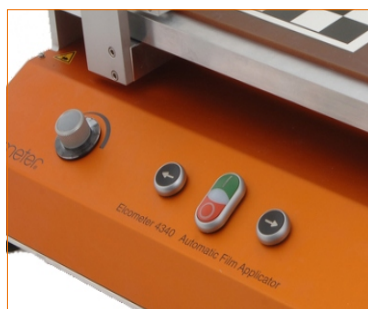

**Smooth & multiple concurrent tests**

- Use up to 3 film applicators simultaneously
- Test up to 2 Leneta test charts simultaneously
- Able to test up to 2 test areas on perforated tables

The Elcometer 4340 Motorised Film Applicators are versatile, rugged and precise. The rigid construction ensures a smooth, consistent application without the ridges often associated with film application.

A range of head attachments is available separately, allowing the user to select the most appropriate for the specific use and Standard (if applicable).

The Elcometer 4340 range of motorised Film Applicators comes as one universal base with user selectable head attachments - allowing the flexibility to test using standard film applicators (filmographs), spiral bar coaters or using the combined attachment of both the film applicator and spiral bar attachment

Each table is engineered to the highest flatness rating, and can be supplied in a number of variations to meet your specific test requirements, simply select the model from the Technical Specification below.

All Elcometer application tables are precision engineered for “perfect” flatness, making them up to 5 times flatter than glass. This accuracy is maintained with our vacuum tables - allowing the testing of thick or thin coated substrates with whilst maintaining the highest levels of accuracy.

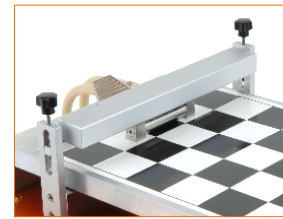

Film Applicator Attachment

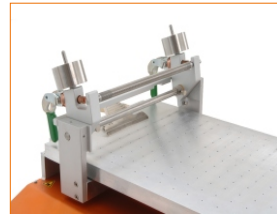

Spiral Bar Attachment

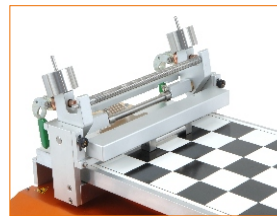

Combined Film Applicator and Spiral Bar Attachment

## Technical Specification

certificate available

Part Number	Voltage	Test Chart Clip	Standard Table	Perforated Vacuum Table	Single Channel Vacuum Table	Double Channel Vacuum Table	Heating Equipment	
							Temperature Bath*	Electrically Heated
							+15 to 100°C (59 to 212°F)	Ambient to 200°C (Ambient to 392°F)
K4340M10-	110 - 240V	▪	▪					
K4340M100	110 - 240V	▪		▪				
K4340M101	110 - 240V	▪			▪			
K4340M102	110 - 240V	▪				▪		
K4340M110	110 - 240V	▪		▪			▪	
K4340M111	110 - 240V	▪			▪		▪	
K4340M120	110 - 240V	▪		▪				▪
Dimensions	780 x 520 x 305mm (30.7 x 20.5 x 12.6")							
Weight	29kg (64lb)							
Packing List	Elcometer 4340 Film Applicator, 3 x power cables (UK, EUR and US) and operating instructions							
<i>Can be used in accordance with: (see Standards Explained inside Front Cover)</i>								
<b>ASTM D 823-C</b>								

## Attachments

### Models

M10-, M100, M101, M102	M110, M111, M120	
KT004340N001	KT004340N101	Film Applicator Attachment
KT004340N002	KT004340N102	Spiral Bar Coater Attachment
KT004340N003	KT004340N103	Combined Film Applicator & Spiral Bar Coater Attachment

\*Supplied ready to be fitted with a temperature bath. Temperature bath is not supplied.

## Leneta Test Charts

Elcometer supplies a wide range of Leneta Test Charts, from plain white to those having different patterns of black and white. Made from naturally bright, non-flourescent white paper, these charts contain no optical brighteners that can affect instrumental colour measurements.

Leneta Test Charts are the market standard in today's coatings industry.

Foil Card substrates of steel, aluminium, glass and plastic are also available. Leneta Test Charts are available in boxes & cases.



### Definitions:

Chart Type:	Description
<i>Opacity Charts:</i>	Used to test the hiding power of the coating, using large black and white areas
<i>Penopac Charts:</i>	Combine penetration and opacity tests in one chart
<i>Display Charts:</i>	Use diagonal patterns to help demonstrate visibly, the hiding power of a coating
<i>Opacity-Display Charts:</i>	Combine large black and white areas with diagonal patterns
<i>Spreading Rate Charts:</i>	Larger than other charts, used to measure the spreading rate of a coating
<i>Brushout Cards:</i>	Thicker paper is used for the testing of coatings applied with a brush or roller
<i>Duplex Applicator Charts:</i>	Used in conjunction with the Duplex Film Applicator to test two coatings at the same time
<i>Unvarnished Charts:</i>	Semi-porous charts which are ideal for clear coatings and stains
<i>Grey Scale Charts:</i>	A range of strips increasing in contrast - ideal for rating the power of a coating
<i>Spray Monitors:</i>	Self-adhesive charts, usually applied to metal panels for testing sprayed and OEM coatings
<i>Scrub Test Panels:</i>	Used to measure the abrasion of a coating, using the Elcometer 1720 Abrasion and Washability Tester, see pages 70 - 74
<i>Metopac™ Test Panels :</i>	Painted steel panels used to measure the hiding power of powder coatings
<i>Printing Ink Drawdown Charts:</i>	Used for testing ink qualities

Can be used in accordance with: (see Standards Explained inside Front Cover)

AS/NZS 1580.213.1, ASTM D 344, ASTM D 2805, ASTM D 2486, ASTM D 5150, DIN 53162-2, FTMS 141 4121, ISO 2814.

## Elcometer 4695 Opacity Charts

The term “Opacity Chart” refers to charts on which the test pattern is a simple combination of black and white areas, large enough for wider aperture reflectance instruments, as well as for visual opacity and colour observations.

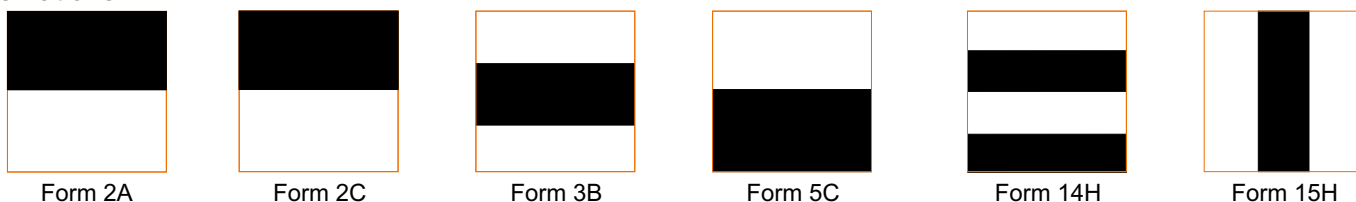

### Technical Specification

Part Number Box	Case	Description	Chart Dimensions		Box Weight	Quantity per Box	Boxes per Case
			mm	inches			
K0004695M003	K0004695M203	Leneta Chart 2A	140 x 254	5½ x 10	2.72kg (6lb)	250	6
K0004695M004	K0004695M204	Leneta Chart 2C	194 x 260	7½ x 10¼	4.08kg (9lb)	250	4
K0004695M006	K0004695M206	Leneta Chart 3B	194 x 289	7⅝ x 11⅜	4.08kg (9lb)	250	4
K0004695M015	K0004695M215	Leneta Chart 5C	194 x 260	7½ x 10¼	4.08kg (9lb)	250	4
K0004695M036	K0004695M236	Leneta Chart 14H	286 x 438	11¼ x 17¼	5kg (11lb)	125	4
K0004695M037	K0004695M237	Leneta Chart 15H	286 x 438	11¼ x 17¼	5kg (11lb)	125	4

## Elcometer 4695 Penopac Charts

These combine the test areas and functions of a PENetration and an OPACity chart and can be considered as universal test charts for research, development and quality control. The choices offered in size and design are responsive to individual laboratory needs and preferences. Form 19BR includes an unsealed black area, but is otherwise equivalent in functionality.

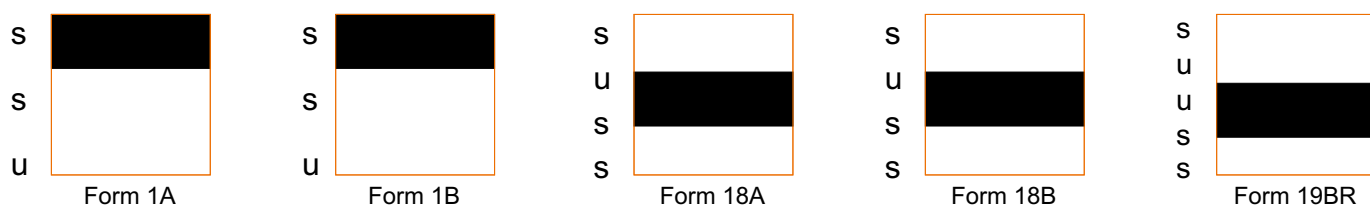

### Technical Specification

Part Number Box	Case	Description	Chart Dimensions		Box Weight	Quantity per Box	Boxes per Case
			mm	inches			
K0004695M001	K0004695M201	Leneta Chart 1A	140 x 254	5½ x 10	2.72kg (6lb)	250	6
K0004695M002	K0004695M202	Leneta Chart 1B	194 x 289	7⅝ x 11⅜	4.08kg (9lb)	250	4
K0004695M038	K0004695M238	Leneta Chart 18A	140 x 254	5½ x 10	2.72kg (6lb)	250	6
K0004695M039	K0004695M239	Leneta Chart 18B	194 x 289	7⅝ x 11⅜	4.08kg (9lb)	250	4
K0004695M040	K0004695M240	Leneta Chart 19BR	194 x 289	7⅝ x 11⅜	4.08kg (9lb)	250	4

s - sealed      u - unsealed

## Elcometer 4695 Brushout Cards

Designed for informal brushout applications, the paper stock is almost twice the thickness of regular chart paper to give greater rigidity for more convenient handling - nominal thickness 0.5mm (20 mils).

Brushout Cards are also used widely for drawdowns and colorimetric measurements.



Form 2DX



Form 5DX

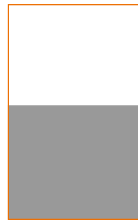

Form 5DX-GW



Form WDX

### Technical Specification

Part Number Box	Case	Description	Chart Dimensions		Box Weight	Quantity per Box	Boxes per Case
			mm	inches			
K0004695M005	K0004695M205	Leneta Chart 2DX	98 x 152	3 7/8 x 6	3.17kg (7lb)	500	4
K0004695M016	K0004695M216	Leneta Chart 5DX	98 x 152	3 7/8 x 6	3.18kg (7lb)	500	4
K0004695M017	K0004695M217	Leneta 5DX-GW	98 x 152	3 7/8 x 6	3.18kg (7lb)	500	4
K0004695M102	K0004695M302	Leneta Chart WDX	98 x 152	3 7/8 x 6	3.18kg (7lb)	500	4

## Elcometer 4695 Duplex Applicator Charts

Originally made to be used with the Duplex Film Applicator, an instrument designed for rapid production of side-by-side drawdowns, they now serve mostly as generic paint test charts.



Form 6F4



Form 6F6



Form WF

### Technical Specification

Part Number Box	Case	Description	Chart Dimensions		Box Weight	Quantity per Box	Boxes per Case
			mm	inches			
K0004695M018	K0004695M218	Leneta Chart 6F4	76 x 184	3 x 7 1/4	2.27kg (5lb)	500	6
K0004695M019	K0004695M219	Leneta Chart 6F6	76 x 184	3 x 7 1/4	2.27kg (5lb)	500	6
K0004695M103	K0004695M303	Leneta Chart WF	76 x 184	3 x 7 1/4	2.27kg (5lb)	500	6

## Elcometer 4695 Display Charts/Spreading Rate

These charts employ time-tested, diagonally striped patterns, having a strong visual impact that emphasises variations in film opacity. They are frequently used for hiding power display purposes, by means of drawdowns or brushouts.

Grey strips in Forms 8H-GW and 8K-GW provide reduced substrate contrast for use with low hiding power coatings.

Spreading Rate Charts (Forms 8H and 8H-GW) are accurately 0.1 square meters (approximately one square

Display Chart



Form 8A



Form 8B



Form 8K

Spreading Rate Chart



Form 8H



Form 8H-GW



Form 8K-GW

### Technical Specification

Part Number Box	Case	Description	Chart Dimensions		Box Weight	Quantity per Box	Boxes per Case
			mm	inches			
K0004695M021	K0004695M221	Leneta Chart 8A	140 x 254	5½ x 10	2.72kg (6lb)	250	6
K0004695M022	K0004695M222	Leneta Chart 8B	194 x 289	7⅝ x 11⅜	4.08kg (9lb)	250	4
K0004695M025	K0004695M225	Leneta Chart 8K	219 x 285	8⅝ x 11¼	5kg (11lb)	250	4
K0004695M023	K0004695M223	Leneta Chart 8H	286 x 438	11¼ x 17¼	5kg (11lb)	125	4
K0004695M024	K0004695M224	Leneta Chart 8H-GW	286 x 438	11¼ x 17¼	5kg (11lb)	125	4
K0004695M026	K0004695M226	Leneta Chart 8K-GW	219 x 285	8⅝ x 11¼	5kg (11lb)	250	4

## Elcometer 4695 Checkerboard Charts/Spreading Rate Charts

One of the earliest hiding power test surfaces was linoleum with a black and white checkerboard pattern.

This was soon replaced by sealed paperboard charts of which Forms 10H and 10H-BG Spreading Rate Charts are typical examples.

Designed for brushout tests at specified rates, such as in ASTM Method D 344 and Canadian 1-GP-71, they are also used for drawdown applications like their similar counterparts Forms 10A and 10B.

Black and grey squares in Form 10H-BG provide reduced contrast for testing coatings with lower hiding power.

Display Chart

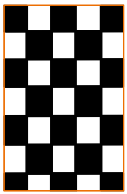

Form 10A

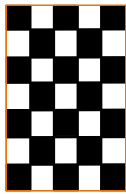

Form 10B

Spreading Rate Chart



Form 10H

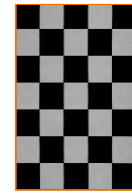

Form 10H-BG

### Technical Specification

Part Number Box	Case	Description	Chart Dimensions		Box Weight	Quantity per Box	Boxes per Case
			mm	Inches			
K0004695M029	K0004695M229	Leneta Chart 10A	140 x 254	5½ x 10	2.27kg (6lb)	250	6
K0004695M030	K0004695M230	Leneta Chart 10B	194 x 289	7⅝ x 11⅜	4.08kg (9lb)	250	4
K0004695M031	K0004695M231	Leneta Chart 10H	286 x 438	11¼ x 17¼	5kg (11lb)	125	4
K0004695M032	K0004695M232	Leneta Chart 10H-BG	286 x 438	11¼ x 17¼	5kg (11lb)	125	4

## Elcometer 4695 Opacity-Display Charts/Spreading Rate Charts

Charts of this type combine the large, unbroken areas that are characteristic of Opacity Charts, with the striped design of a Display Chart. The larger areas permit wide aperture photometric measurements and visual colour comparisons, while the striped area is uniquely effective for hiding power comparison and display. Spreading Rate Charts (Forms 12H and 13H) are accurately 0.1 square metres (approximately one square foot) in area, and are designed for brushout application at specified spreading rates.



### Technical Specification

Part Number Box	Case	Description	Chart Dimensions		Box Weight	Quantity per Box	Boxes per Case
			mm	inches			
K0004695M027	K0004695M227	Leneta Chart 9A	140 x 254	5 1/2 x 10	2.72kg (6lb)	250	6
K0004695M028	K0004695M228	Leneta Chart 9B	194 x 289	7 5/8 x 11 3/8	4.08kg (9lb)	250	4
K0004695M041	K0004695M241	Leneta Chart 21B	194 x 289	7 5/8 x 11 3/8	4.08kg (9lb)	250	4
K0004695M033	K0004695M233	Leneta Chart 12H	286 x 438	11 1/4 x 17 1/4	5kg (11lb)	125	4
K0004695M034	K0004695M234	Leneta Chart 13H	286 x 438	11 1/4 x 17 1/4	5kg (11lb)	125	4

## Elcometer 4695 Metopac™ Metal Test Panels

Painted steel panels, used for measuring the hiding power of powder coatings and industrial enamels.

Available in half black/half white and all black.

### The black surface:

Solvent Resistant, Non bleeding, Reflective

- 1% maximum - measured using ASTM Method E1347

### White Surface:

Solvent Resistant, Colour Retentive, Reflective, Reflectance

- 80% minimum - measured using ASTM Method E1347

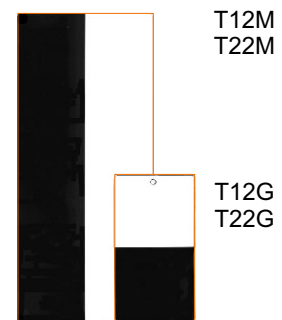

### Technical Specification

Part Number Box	Case	Description	Chart Dimensions		Box Weight	Quantity per Box	Boxes Per Case
			mm	inches			
K0004695M094	K0004695M294	Leneta Panel T12G	76 x 132	3 x 5 3/16	3.63kg (8lb)	125	4
K0004695M095	K0004695M295	Leneta Panel T12M	132 x 279	5 3/16 x 11	1.81kg (4lb)	50	4
K0004695M096	K0004695M296	Leneta Panel T22G	76 x 132	3 x 5 3/16	3.63kg (8lb)	125	4
K0004695M097	K0004695M297	Leneta Panel T22M	132 x 279	5 3/16 x 11	0.91kg (2lb)	50	4



## Elcometer 4695 Plain White & Plain Black Charts

Available in varying thicknesses and size. The Leneta WBX, WDX, WA, and WB cards all come with convenience hole at the top.

W: White  
B: Black

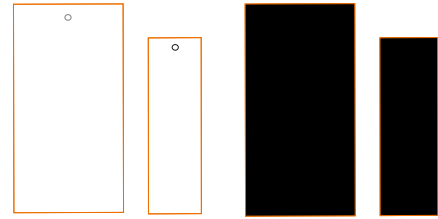

### Technical Specification

Part Number Box	Case	Description	Chart Dimensions		Box Weight	Quantity per Box	Boxes per Case
Card thickness 0.5mm			mm	inches			
K0004695M100	K0004695M300	Leneta Chart WBX	194 x 286	7 <sup>5</sup> / <sub>8</sub> x 11 <sup>1</sup> / <sub>4</sub>	3.18kg (7lb)	125	4
K0004695M102	K0004695M302	Leneta Chart WDX	98 x 152	3 <sup>7</sup> / <sub>8</sub> x 6	3.18kg (7lb)	500	4
K0004695M106	K0004695M306	Leneta Chart WHX	286 x 483	11 <sup>1</sup> / <sub>4</sub> x 17 <sup>1</sup> / <sub>4</sub>	4.54kg (10lb)	75	4
K0004695M108	K0004695M308	Leneta Chart WKX	219 x 286	8 <sup>5</sup> / <sub>8</sub> x 11 <sup>1</sup> / <sub>4</sub>	3.63kg (8lb)	125	4
Card thickness 0.3mm							
K0004695M098	K0004695M298	Leneta Chart WA	140 x 254	5 <sup>1</sup> / <sub>2</sub> x 10	2.72kg (6lb)	250	6
K0004695M099	K0004695M299	Leneta Chart WB	194 x 286	7 <sup>5</sup> / <sub>8</sub> x 11 <sup>1</sup> / <sub>4</sub>	4.45kg (10lb)	250	4
K0004695M101	K0004695M301	Leneta Chart WD	98 x 152	3 <sup>7</sup> / <sub>8</sub> x 6	4.54kg (10lb)	1000	4
K0004695M103	K0004695M303	Leneta Chart WF	76 x 184	3 x 7 <sup>1</sup> / <sub>4</sub>	2.27kg (5lb)	500	6
K0004695M104	K0004695M304	Leneta Chart WG	76 x 140	3 x 5 <sup>1</sup> / <sub>2</sub>	3.63kg (8lb)	1000	4
K0004695M105	K0004695M305	Leneta Chart WH	286 x 438	11 <sup>1</sup> / <sub>4</sub> x 17 <sup>1</sup> / <sub>4</sub>	5kg (11lb)	125	4
K0004695M107	K0004695M307	Leneta Chart WK	219 x 286	8 <sup>5</sup> / <sub>8</sub> x 11 <sup>1</sup> / <sub>4</sub>	5kg (11lb)	250	4
K0004695M109	K0004695M309	Leneta Chart WM	140 x 286	5 <sup>1</sup> / <sub>4</sub> x 11 <sup>1</sup> / <sub>4</sub>	2.72kg (6lb)	250	6
K0004695M049	K0004695M249	Leneta Chart BH	286 x 438	11 <sup>1</sup> / <sub>4</sub> x 17 <sup>1</sup> / <sub>4</sub>	0.45kg (1lb)	125	4
K0004695M050	K0004695M250	Leneta Chart BK	219 x 286	8 <sup>5</sup> / <sub>8</sub> x 11 <sup>1</sup> / <sub>4</sub>	5kg (11lb)	250	4

## Elcometer 4695 Unvarnished Test Charts

Unvarnished Test Charts are ideal for testing applications of clear coatings and stains.

The unvarnished (semi-porous) surface simulates wood or unsealed wallboard.



Form N2C

Form N2A

Form N9A

Form

### Technical Specification

Part Number Box	Case	Description	Chart Dimensions		Box Weight	Quantity per Box	Boxes per Case
			mm	Inches			
K0004695M064	K0004695M264	Leneta Chart N2A	140 x 254	5 <sup>1</sup> / <sub>2</sub> x 10	2.72kg (6lb)	250	6
K0004695M065	K0004695M265	Leneta Chart N2C	194 x 260	7 <sup>5</sup> / <sub>8</sub> x 10 <sup>1</sup> / <sub>4</sub>	4.08kg (9lb)	250	4
K0004695M066	K0004695M266	Leneta Chart N9A	140 x 254	5 <sup>1</sup> / <sub>2</sub> x 10	2.72kg (6lb)	250	6
K0004695M067	K0004695M267	Leneta Chart NWK	219 x 286	8 <sup>5</sup> / <sub>8</sub> x 11 <sup>1</sup> / <sub>4</sub>	5kg (11lb)	250	4
K0004695M110	K0004695M210	Leneta Chart WP-1	140 x 254	5 <sup>1</sup> / <sub>2</sub> x 10	2.72kg (6lb)	250	6

## Elcometer 4695 Grey Scale Charts

These are sealed paint test charts with six stripes on a white field, ranging in shade from very light grey to black. The stripes are numbered 1 to 6, representing uniform steps of increasing contrast. The hiding power of the applied coatings is rated as the number of the darkest stripe that is completely (or almost completely) obscured, at a specified thickness or spread rate. Form CU-1 is used for more practical large-area brush or roller applications as in ASTM D5150. Applications on Form 24B are made with a drawdown blade.



Form CU-1



Form 24B

### Technical Specification

Part Number		Description	Chart Dimensions		Box Weight	Quantity per Box	Boxes per Case
Box	Case		mm	inches			
K0004695M053	-	Leneta Chart CU-1	610 x 946	24 x 37 <sup>1/4</sup>	22.68kg (50lb)	100	1
K0004695M043	K0004695M243	Leneta Chart 24B	194 x 289	7 <sup>5/8</sup> x 11 <sup>3/8</sup>	4.08kg (9lb)	250	4

## Elcometer 4695 Spray Strips - Hiding Power for OEM

These are used by industrial coatings laboratories, principally those involved with the automotive industry, to measure the hiding power of spraying enamels. The chart is attached to a steel panel and the test coating sprayed to produce a "wedge" varying from thin at one end to thick at the other.

After drying, a location on the chart of adequate visual hiding or 0.98 contrast ratio is determined, and the film thickness measured electronically on the steel panel adjacent to that location. Conversely, a location of specified thickness is determined on the steel panel and the contrast ratio measured adjacent to that location.



Form S71



Form S71-BG



Form S72

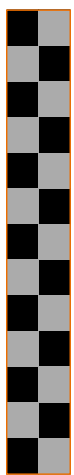

Form S72-BG

### Technical Specification

Part Number		Description	Chart Dimensions		Box Weight	Quantity per Box	Boxes per Case
Box	Case		mm	inches			
K0004695M089	K0004695M289	Leneta Strips S71	51 x 279	2 x 11	2.27kg (5lb)	500	4
K0004695M090	K0004695M290	Leneta Strips S71-BG	51 x 279	2 x 11	2.27kg (5lb)	500	4
K0004695M091	K0004695M291	Leneta Strips S71-RG	51 x 279	2 x 11	2.27kg (5lb)	500	4
K0004695M092	K0004695M292	Leneta Strips S72	51 x 279	2 x 11	2.27kg (5lb)	500	4
K0004695M093	K0004695M293	Leneta Strips S72-BG	51 x 279	2 x 11	2.27kg (5lb)	500	4

## Elcometer 4695 Spray Monitors - Self Adhesive Hiding Power

These are pressure sensitive labels with a hiding power test pattern and a sealed, solvent-resistant surface. They are used primarily with metal panels on which the panel alone provides no visual clue as to the thickness of the applied paint film.

When placed on such a surface the Monitor presents a contrasting feature by which to observe how well the coating hides the surface, thereby facilitating film thickness control. It adheres firmly whether air-dried or baked, to present a permanent visual record of film opacity.

Available in Black/White, Black/Grey and also Red/Grey (not shown).



Form M33



Form M33-BG



Form M12



Form M12-BG

### Technical Specification

Part Number Box	Case	Description	Chart Dimensions		Box Weight	Quantity per Box	Boxes per Case
			mm	Inches			
K0004695M059	K0004695M259	Leneta Spray Monitor M33	51 x 51	2 x 2	0.91kg (2lb)	500	4
K0004695M058	K0004695M258	Leneta Spray Monitor M33-BG	51 x 51	2 x 2	0.91kg (2lb)	500	4
K0004695M060	K0004695M260	Leneta Spray Monitor M33-RG	51 x 51	2 x 2	0.91kg (2lb)	500	4
K0004695M056	K0004695M256	Leneta Spray Monitor M12	25 x 25	1 x 1	0.91kg (2lb)	2000	4
K0004695M055	K0004695M255	Leneta Spray Monitor M12-BG	25 x 25	1 x 1	0.91kg (2lb)	2000	4
K0004695M057	K0004695M257	Leneta Spray Monitor M12-RG	25 x 25	1 x 1	0.91kg (2lb)	2000	4
K0004695M061	K0004695M261	Leneta Spray Monitor M71	51 x 279	2 x 11	2.72kg (6lb)	500	4
K0004695M062	K0004695M262	Leneta Spray Monitor M71-BG	51 x 279	2 x 11	2.72kg (6lb)	500	4
K0004695M063	K0004695M263	Leneta Spray Monitor M72	51 x 279	2 x 11	2.72kg (6lb)	500	4
K0004695M079	K0004695M279	Leneta Spray Monitor M72-BG	51 x 279	2 x 11	2.72kg (6lb)	500	4

## Elcometer 4695 Printing Ink Drawdown Sheets

Available in different grades of paper, these sheets provide a variety of substrates for testing ink qualities. They are also useful for testing other coatings because of their absorbency and texture range.



Form 3NT-31



Form 3NT-4

### Technical Specification

Part Number Box	Case	Description	Chart Dimensions		Box Weight	Quantity per Box	Boxes per Case
			mm	inches			
K0004695M010	K0004695M310	Leneta Sheets 3NT-4	127 x 194	5 x 7 <sup>5</sup> / <sub>8</sub>	2.27kg (5lb)	1000	6
K0004695M116	K0004695M316	Leneta Sheets 3NT-31*	127 x 194	5 x 7 <sup>5</sup> / <sub>8</sub>	3.63kg (8lb)	1000	6
K0004695M117	K0004695M317	Leneta Sheets 3NT-32	127 x 194	5 x 7 <sup>5</sup> / <sub>8</sub>	2.72kg (6lb)	500	6

\* These sheets contain optical brighteners and are a heavier paper weight.

## Elcometer 4695 Scrub Test Panels

In a typical scrub test, the coating is applied to the Leneta Scrub Test Panel at a specified film thickness, allowed to dry and then subjected to scrubbing with a straight-line scrub tester.

When used in accordance with ASTM D2486, Method A, a 10 mil shim is inserted under the panel to accelerate failure and thereby reduce testing time. The scrub resistance is the number of scrub cycles required to remove the coating to a specified end point.

Alternatively, the loss in weight is determined after a specified number of scrub resistance cycles, with calculation of equivalent loss in film thickness.

These Scrub Test Panels are ideal for use with the Elcometer 1720 Washability & Abrasion Testers; see pages 70 - 72.

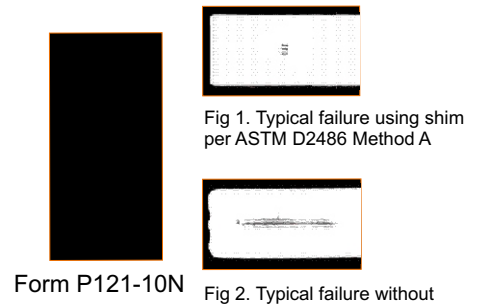

### Technical Specification

Part Number		Description	Chart Dimensions		Quantity per Box	Boxes per Case
Box	Case		mm	inches		
K0004695M068	K0004695M268	Leneta Scrub Test Panel P121-10N	165 x 432	6 1/2 x 17	100	5
K0004695M069	K0004695M269	Leneta Scrub Test Panel P122-10N	165 x 432	6 1/2 x 17	100	5

Customers who purchased the Elcometer 4695 also purchased:



◀ Elcometer 1615 Impact Tester, page 102 - 106

Elcometer 1720 Washability Tester, page 70 - 74



## Drying Time

When developing a coating process, it is important to know the exact time it takes for the coating to dry or cure. For multicoat paint systems, having knowledge of the drying time enables the operator to know when any subsequent layers can be applied.

There are many stages involved in the coating drying time. Once a coating has been applied, it levels off under gravity, and, as the coating begins to cure, a thin dry film appears on the surface. The coating then continues to dry until, finally, it is totally cured.

- **Linear and Rotary Methods:**

Both function in a similar manner and calculate the drying time using the principle that

$$\text{Distance} = \text{Speed} \times \text{Time}$$

A ball tip is placed into the coating being tested and the drying time recorder begins to move the ball at a predefined speed. As the coating dries, the visual trace left in the coating by the ball identifies each stage of the cure.

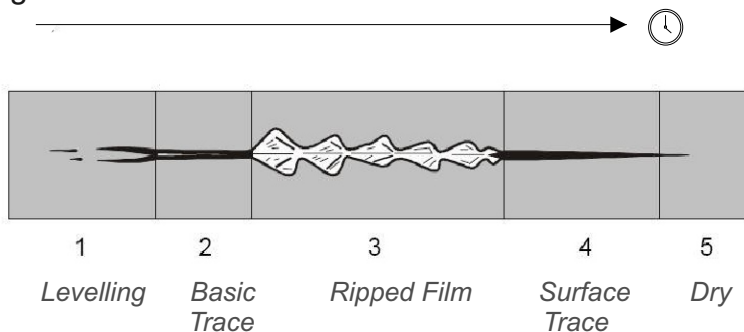

### Definitions:

- **Permeability:** describes how much and how fast moisture transfers through a film as vapour. The film is gripped between a ring fitted with a seal and the cup, which contains a quantity of water or desiccant.
- **Permeability Cups and Meier Gauges:** When applying a multicoat system, it is often acceptable to apply a subsequent coat before the previous coat has fully cured. Payne Permeability Cups can be used to determine the degree to which the volatile liquid can permeate any subsequent layer.

Typically, a coating cures from the surface down to the substrate leaving a “skin” on the surface. As the volatile liquid evaporates, the coating thickness reduces and, dependent on the film thickness, may crack. The Meier gauge visually tests the shrinking and/or cracking of a coating.

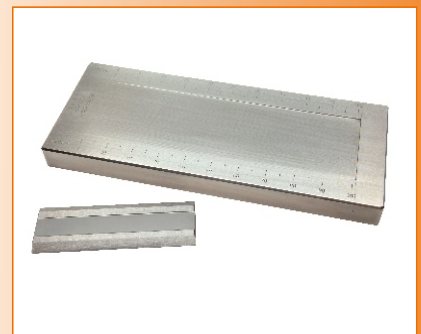

## Elcometer 5500 Circular Drying Time Recorder

This simple device uses the principle of  $distance = speed \times time$  to determine the drying time of a coating.

A 10mm (0.39") diameter Teflon<sup>®</sup> stylus is brought into contact with a freshly coated test piece under a load of 12g (0.42oz) and traces a circle of 50mm (1.96") diameter.

The drying time is evaluated from the condition of the trace and measured with a template with time markings.

The template is transparent and placed over the test piece and readings taken at the point of the markings on the test piece, showing the length of time taken for each stage of the curing process.



### Technical Specification



Part Number			Description	Speed
UK 240V	EUR 220V	US 110V		
<a href="#">K0UK5500M001</a>	<a href="#">K0005500M001</a>	<a href="#">K0US5500M001</a>	Circular Drying Time Recorder	1 Revolution every 1 hour
<a href="#">K0UK5500M002</a>	<a href="#">K0005500M002</a>	<a href="#">K0US5500M002</a>	Circular Drying Time Recorder	1 Revolution every 6 hours
<a href="#">K0UK5500M003</a>	<a href="#">K0005500M003</a>	<a href="#">K0US5500M003</a>	Circular Drying Time Recorder	1 Revolution every 12 hours
<a href="#">K0UK5500M004</a>	<a href="#">K0005500M004</a>	<a href="#">K0US5500M004</a>	Circular Drying Time Recorder	1 Revolution every 24 hours
Stylus Diameter	4.75mm (0.625") tracing a 50mm (1.96") diameter circle			
Dimensions	140 x 130 x 190mm (5.5 x 5.1 x 7.5")			
Weight	1.5kg (3.3lb)			
Packing List	Elcometer 5500, 12g (0.42oz) weight, transparent timing template and operating instructions			
<i>Can be used in accordance with: (see Standards Explained inside Front Cover)</i>				
<a href="#">ASTM D5895-B</a>				

### Accessories

<a href="#">KT005500P001</a>	10mm (0.39") Stylus Tool, pack of 5
<a href="#">KT005500F006</a>	12g (0.42oz) Weight
<a href="#">KT005500F011</a>	Transparent Timing Template 12 to 24 hours
<a href="#">KT005500F012</a>	Transparent Timing Template 1 to 6 hours

## Elcometer 5300 Linear Drying Time Recorder

The Elcometer 5300 is designed to determine paint drying time by linear recording, with up to 10 positions (5 each side of the centre column) tested simultaneously.

Ten rods with hemispherical tips, fitted to a carriage, are brought into contact with the fresh films at one end of the test piece and moved lengthwise.

The drying time is calculated from the distance travelled, measured using a graduated rule along the edge, corresponding to the various stages observed on the trace.

The coatings are applied beforehand on glass strips 25mm (0.98") wide and 700mm (27.5") long. Using the Elcometer 3505 Cube Film Applicators (see page 49), it is possible to apply up to five coatings simultaneously on a glass plate.

- The drying time recorder automatically stops at the end of travel
- The load on each ball is 11g (0.37oz), although additional weights can bring this load up to 21g (0.71oz)



### Technical Specification

 certificate available

Part Number	Description	
UK 240V	EUR 220V	US 110V
<b>K0UK5300M002</b>	<b>K0005300M002</b>	<b>K0US5300M002</b> Elcometer 5300 Linear Drying Time Recorder
Tool Diameter	4.76mm (0.19")	
Speed	6 speeds, between 12mm (0.5") and 600mm (24") per hour	
Dimensions	860 x 420 x 170mm (34 x 16.5 x 6.7")	
Weight	18kg (40lb)	
Packing List	Elcometer 5300, 12 glass strips, 10 x 10g (0.35oz) weights and operating instructions	

### Accessories

<b>KT005300P001</b>	Glass Strip 700 x 25mm (28 x 1"), set of 10
<b>KT005300P002</b>	Ball Tool - set of 5
<b>KT005300P003</b>	Additional 10g (0.35oz) Weights, set of 5
<b>KT005300P004</b>	Glass Plate 700 x 145mm (28 x 5.7"), set of 6
<b>K0003505M001</b>	Elcometer 3505/1 Metric Cube Film Applicator - 1 Stripe - see page 47 for details
<b>K0US3505M001</b>	Elcometer 3505/1 Imperial Cube Film Applicator - 1 Stripe - see page 47 for details
<b>K0003505M202</b>	Elcometer 3505/2 Metric Cube Film Applicator - 5 Stripes - see page 47 for details
<b>K0US3505M202</b>	Elcometer 3505/2 Imperial Cube Film Applicator - 5 Stripes - see page 47 for details

## Elcometer 2080 Meier Gauge

The Elcometer 2080 Meier gauge is made of hardened stainless steel to test drying, shrinking or cracking of coatings or similar products against their thickness, with a sloping groove 60mm (2.36") wide and 200mm (7.87") long, with options of 1, 2 or 3mm maximum depth.

The test products are applied to the whole area of the groove and visually inspected after they have dried. Each model has one groove.



### Technical Specification

certificate available

Part Number		Model	Range		Graduation
Metric	Imperial		µm	mils	mm
K0002080M001	K0US2080M001	Elcometer 2080/1	0 - 1000	0 - 40	0.05
K0002080M002	K0US2080M002	Elcometer 2080/2	0 - 2000	0 - 80	0.10
K0002080M003	-	Elcometer 2080/3	0 - 3000	-	0.15
Dimensions	250 x 100 x 20mm (9.8 x 3.4 x 0.8")				
Weight	4.54kg (10lb)				
Packing List	Elcometer 2080 Meier Gauge, scraper, carry case and operating instructions				

## Elcometer 5100 Payne Permeability Cups

The Elcometer 5100 Payne Permeability Cups are made entirely from anodised aluminium and are used to determine the permeability of films of paints, varnish, plastic, cellophane, etc.

The water evaporates or is absorbed and, after a certain time, the weight change relative to the film thickness is calculated, indicating the degree of permeability or permeance.



### Technical Specification

Part Number	Description	Area		Volume	
		cm <sup>2</sup>	inches <sup>2</sup>	cm <sup>3</sup>	inches <sup>3</sup>
K0005100M201	Elcometer 5100/1 Payne Permeability Cup	10	1.55	15	0.91
K0005100M202	Elcometer 5100/2 Payne Permeability Cup	30	4.65	50	3.05
K0005100M203	Elcometer 5100/3 Payne Permeability Cup	30	4.65	75	4.58
Packing List	Elcometer 5100 Payne Permeability Cup, storage case and operating instructions				

Can be used in accordance with: (see Standards Explained inside the Front Cover)

ASTM D1653, ASTM E96, ISO 7783, NF T30-018, NF T34-721-2



## Washability, Brushability & Abrasion

Improved mechanical resistance to wear is a key requirement of a wide range of products. From coatings to clothing, leather to upholstery, keypads to plastic toys, a product's ability to resist wear is an important characteristic.

There are testing methods relating to the 'abrasion by friction' concept. Others are based on the projection of abrasive particles on to the test specimen. These techniques provide valuable information about materials and processes.

The three tests available are:

- **Friction:** one part moves relative to the other
- **Scrubbing:** wet or dry brush or sponge is moved over the test piece
- **Blast:** abrasive particles are projected on to the test specimen

Although it is difficult to correlate test performance with real life wear conditions, mechanical tests can make an accurate comparison.

- **Washability:**  
The ability of a coating to withstand being washed using either wet or dry scrubbing action. The effect can be determined in terms of coating weight loss, loss of gloss or loss of thickness after the scrubbing process.
- **Brushability/Spongeability:**  
The degree to which a wall covering resists washing with either a brush or a sponge, usually a sponge using a fixed testing regime, e.g the number of cycles, weight and size of sponge, etc.
- **Abrasion:**  
The ability of a coating to resist damage caused by a defined material rubbing its surface. Abrasive wear is the erosion of material from a solid surface by the action of another solid.



## Elcometer 1720 Washability & Abrasion Testers

These robust, reliable and extremely versatile machines have been designed for testing the abrasion, washability, brushability and resistance of a wide range of materials including paint, lacquers, inks, coatings, leather, wood, plastics, printed material, fabrics etc.

The Elcometer 1720 is available with either 2 or 4 stations, each station is separated by a water-tight gasket frame, allowing up to 4 dry or wet tests at any one time.

Made from anodised aluminium making it durable and robust

The durable and robust design is steady under test allowing repeatable test results, even at the fastest stroke speeds

Test up to 4 samples simultaneously



Speed Cycles can be adjusted from 10 to 65 cycles per minute or set to the ISO Standard of 37 cycles/min

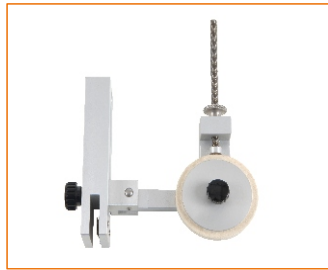

### Meeting Standards

- With the wide range of tools available many Standards can be tested in one unit
- All units can be used in accordance with ASTM, DIN, EN and ISO Standards
- Easily adjustable to customers unique applications using the special tools

Rapid tool change

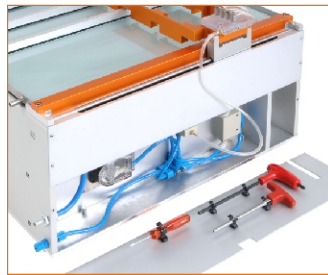

Multi-lingual digital display

### Wet and Dry

- All stations can be tested wet or dry
- Versions are available with or without an internal liquid pump
- Samples can be tested under wet and/or dry conditions simultaneously

Available with or without an integrated liquid dosing pump



### User Adjustable

- Stroke length can be quickly and easily changed by the user to meet their specific requirements between 10 - 300mm (0.4 - 11.8")
- Speed of carriage can be adjusted between 10 and 65 cycles per minute

Adjustable stroke length from 10 to 300mm (0.4 to 11.8")



### Interchangeable Tools

- All tools are interchangeable with a rapid tool change system, making the unit ideal for use in accordance with a wide range of Standards.

For the complete range of tools, see pages 73 - 74

With a wide range of tools available, the user is able to test both flat and curved samples

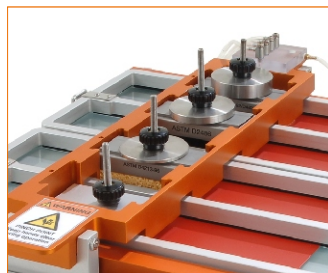

### Economic

- With the ability to test up to 4 different characteristics simultaneously, significant time can be saved

# Washability & Abrasion

elcometer®



Available in 2 versions:  
2 station - undertakes two tests at a time,  
4 station - tests up to four samples with 4 different tests.



Stroke speed can be varied between 10 and 65 cycles/min or set to 37 cycles/min to meet ISO Standards



Stroke length can be adjusted by the user to meet specific requirements, from 10 to 300mm (0.4 to 11.8")



Available with or without liquid dosers, allowing test liquids to be regulated automatically or independently



Digital display allows easy, accurate speed variation and simple reporting

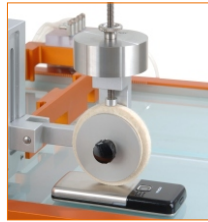

The rapid tool change system allows the user to test the samples in accordance with a wide range of National and International Standards on both flat and curved samples simultaneously

## Technical Specification

 certificate available

Part Number	Description
<b>K1720M202</b>	Elcometer 1720 Abrasion Tester, 2 Station (110 - 240V)
<b>K1720M204</b>	Elcometer 1720 Abrasion Tester, 4 Station (110 - 240V)
<b>K1720M302</b>	Elcometer 1720 Abrasion & Washability Tester, 2 Station (110 - 240V)
<b>K1720M304</b>	Elcometer 1720 Abrasion & Washability Tester, 4 Station (110 - 240V)
Dimensions	550 x 460 x 320mm (21.7 x 18.1 x 12.6")
Weight	2 Station: 31.5kg (70lb), 4 Station: 33kg (73lb)
Packing List	Elcometer 1720, 250µm (10mil) metal strip for ASTM D2486 Standard, sample drip tray, 1x glass sheet (2 station), 2x glass sheet (4 station), 1x specimen holding frame (2 station), 2x specimen holding frame (4 station), set of 3 tools for instrument set up, 3 x mains leads (UK, EUR and US) and operating instructions. Elcometer 1720 part numbers K1720M302 and K1720M304 also include a liquid dosing bottle, liquid delivery pipe and 2 liquid drain pipes. Tools are supplied separately, please order from the list on pages 73 - 74.

Can be used in accordance with: (see Standards Explained inside Front Cover)

AS/NZS 1580.459.1, ASTM D 4488, DIN 53778-2:1983, ASTM D 2486, ASTM D 4213:92, ASTM D 3450, ASTM D 4213, ISO 11998, PSAD45 1010, ECCAT10, EN 13523-11, EN 60730-1-A, EN 233:1989, EN 12956

**Elcometer 1720 Tools and Accessories**

The Elcometer 1720 can undertake tests according to a wide range of different Standards and Test Methods by simply changing the abrasive tools. For more information on Standards, please see inside Front Cover. Please select the required tools from the list on the following two pages. Samples can be tested in a combination of both wet and dry methods.



**Tool 1:** Wild Boar Brush

*Can be used in accordance with:*  
**DIN 53778**

Wild boar hair brush and stainless steel brush holder. Total weight: 250g (8.82oz)

Part Number: **KT001720P003**



**Tool 2:** Nylon Brush

*Can be used in accordance with:*  
**ASTM D2486**

Nylon bristle brush, stainless steel brush holder and 177g (6.2oz) mass. Total weight: 454g (16.01oz)

Part Number: **KT001720P030**



**Tool 3:** Sponge

*Can be used in accordance with:*  
**ASTM D4213-92, ASTM D4828**

Sponge and stainless steel brush holder, 337g (11.9oz). Total weight: 508g (17.92oz)

Part Number: **KT001720P005**



**Tool 4:** Sponge

*Can be used in accordance with:*  
**ASTM D3450**

Sponge and stainless steel brush holder, 337g (11.9oz) and 250g (8.8oz) mass to bring gross weight to 750g. Total weight: 750g (26.45oz)

Part Number: **KT001720P073**



**Tool 5:** Sponge / Abrasive

*Can be used in accordance with:*  
**ASTM D4213-96**

Sponge & stainless steel holder abrasive pads - top and bottom & 76g (2.7oz) mass. Total weight: 232g (8.12oz)



**Tool 6:** Abrasive

*Can be used in accordance with:*  
**ISO 11998**

Aluminium holder, abrasive pads (x5). Total weight: 135g (4.76oz)

Part Number: **KT001720P036**



**Tool 7:** Universal Material Clamp

Stainless steel holder allowing users to fix their own test sample or abrasive material. Ideal for abrasion and wear of labels, textiles, ink etc.

Part Number: **KT001720P207**



**Tool 8:** Linear Abrader "Crockmeter"

*Can be used in accordance with:*  
**ASTM F1319, ISO 105X12, Renault D45 1010**

This tool is ideal for testing abrasion on both curved and flat surfaces and for testing colour fastness of fabrics. Supplied with a removable stainless steel rod, test felt, textile fixing ring and a set of additional masses - 2x100g (3.5oz), 1x200g (7oz), 1x500g (17.6oz). Total weight (excluding masses): 200g (7.05oz)

Part Number: **KT001720P074**



**Tool 9:** Linear Abrader

Can be used in accordance with:  
**GME 60269**

For testing the resistance to abrasion of automotive components, includes a felt disc of 10mm (0.4") diameter and 10mm (0.4") thick working under a mass of 400g (14.1oz). Total weight: 400g (14.11oz)

Part Number: **KT001720P075**



**Tool 9B:** Linear Abrader

Can be used in accordance with:  
**EN 13523-11**

Felt holder for 16mm (0.63") diameter felt wool disc working under a mass of 900g (31.7oz)  
Total weight: 900g (31.74oz)

Part Number: **KT001720P075-2**



**Tool 9A:** Linear Abrader

Can be used in accordance with:  
**ECCAT11**

As Tool 9 but with 16mm (0.63") diameter felt wool disc. Total weight: 820g (28.9oz)

Part Number: **KT001720P075-1**



**Tool 10:** Curved Sample Tool

Can be used in accordance with:  
**EN 60730-1**

Height adjustable with an elbow joint for curved samples, this tool is ideal for testing abrasion resistance of both coatings and inks. Supplied with felt disc, rod for masses, 1x50g (1.75oz), 1x100g (3.5oz), 2x200g (7oz) and 2x500g (17.5oz) mass

Part Number: **KT001720N003**

## Accessories

<b>KT001720P004</b>	Wild Boar Brush for Tool 1
<b>KT001720P009</b>	Nylon Brush for Tool 2
<b>KT001720P006</b>	Sponge (5) for Tools 3 & 4
<b>KT001720P141</b>	Sponge/Abrasive (5) for Tool 5
<b>KT001720P037</b>	Abrasive Pads (10) for Tool 6
<b>KT001720P064</b>	Abrasive Pads (100) for Tool 6
<b>KT001720P051</b>	Abrasive G 120 Sheets (4), for Tools 1 & 2
<b>KT001720P008</b>	25m Abrasive Roll for Tool 7
<b>KT001720P062</b>	Felt Disks (2) for Tool 10
<b>KT001720N002</b>	Abrasive Scrub Medium - SC2
<b>KT001720P016</b>	50g Mass (To fit tools 1 - 8, 10)
<b>KT001720P017</b>	100g Mass (To fit tools 1 - 8, 10)
<b>KT001720P018</b>	200g Mass (To fit tools 1 - 8, 10)
<b>KT001720P031</b>	227g Mass (To fit tools 1 - 8, 10)
<b>KT001720P019</b>	500g Mass (To fit tools 1 - 8, 10)
<b>KT001720P214</b>	Glass Plate, 478 x 165mm
<b>KT001720P012</b>	ASTM Test Foil 250um (10mils)
<b>KT001720P013</b>	10m Replacement Channel Gasket
<b>KT001720N011</b>	2 Channel to 4 Channel upgrade kit for Elcometer 1720 Abrasion Tester, 2 Station
<b>KT001720N111</b>	2 Channel to 4 Channel upgrade kit for Elcometer 1720 Abrasion & Washability Tester, 2 Station

## Elcometer 1720 Spongeability and Washability Tester

This version of the Elcometer 1720 is adapted for testing the spongeability and washability of paper wall coverings in accordance with the EN 233 Standard.

The test consists of scrubbing the sample with a tool under defined conditions.

Features:

- Variable speed mode - the operator can select a speed from 10 to 120 cycles per minute. (1 cycle = 1 motion back and forth of the carriage)
- 1 or 2 specimen fastening frames are supplied for the 2 and 4 station models respectively

Please note that each tool is available as a separate item and should be ordered as required from the list below.



### Technical Specification

**C** certificate available

Part Number	Description
<b>K1720M402</b>	Elcometer 1720 Spongeability/Washability Tester, 2 Station (110 - 240V)
<b>K1720M404</b>	Elcometer 1720 Spongeability/Washability Tester, 4 Station (110 - 240V)
Dimensions	550 x 460 x 320mm (21.7 x 18.1 x 12.6")
Weight	2 Station: 31.5kg (70lb), 4 Station: 33kg (73lb)
Packing List	Elcometer 1720, 250um (10mil) metal strip for ASTM D2486 Standard, sample drip tray; 1x glass sheet; (2 station), 2x glass sheet (4 station), 1x specimen holding frame (2 station), 2x specimen holding frame (4 station), set of 3 tools for instrument set up, liquid dosing bottle, liquid delivery pipe, 2 x liquid drain pipe, 3 x mains leads (UK, EUR and US) and operating instructions

Can be used in accordance with: (see Standards Explained inside Front Cover)

**EN 233, EN 233/C3.2-A, EN 233/C3.2-B, EN 233/C3.2-C, EN12956**

### Tools and Accessories

<b>KT001720N006</b>	Tool ST1: Sponge with Aluminium Head and 100g (3.5oz) mass	EN233/C3.2-A, EN12956
<b>KT001720N007</b>	Tool ST2: Felt with Stainless Steel Head and 550g (19.4oz) mass	EN233/C3.2-B, EN12956
<b>KT001720N008</b>	Tool ST3: Brush with Stainless Steel Head and 600g (21.2oz) mass	EN233/C3.2-C
<b>KT001720N208</b>	Tool ST4: Brush with Stainless Steel Head and 600g (21.2oz) mass	EN12956
<b>KT001720P067</b>	Tool ST1: 2m Sponge Roll	
<b>KT001720P068</b>	Tool ST2: 2m Felt Roll	
<b>KT001720P069</b>	Tool ST3: Brush	
<b>KT001720P269</b>	Tool ST4: Brush	

## Elcometer Taber® 5750 Linear Abraser

Whatever your product, be it curved, round, big or small, the Linear Abraser from Taber® can test it all. Using a free floating head to follow the contours of the sample, the Taber® 5750 is the ideal abrasion tester for flat or curved surfaces. It may also be used as a scratch tool, using the scratch kit accessory.

Abrasion media, length of stroke, load and speed of stroke can all be user defined to meet specific requirements.

The Linear Abraser uses a range of Wearasers™. The size and shape of a pencil eraser, the Wearaser™ uses the same high quality Taber® abrasive media as used on the Taber® Rotary Abrasers, simulating real-life wear conditions. Please see page 78 for the complete range.

### Features:

- Stroke lengths of 12.7, 25, 76 and 102mm (0.5, 1.0, 3.0 and 4.0")
- Variable stroke speed from 2 - 75 cycles per minute
- Preset stroke speed buttons for 2, 15, 25, 30, 40 and 60 cycles per minute
- Variable load from 350 - 2100g (12.4 - 74.1oz) with optional weights
- Stainless steel Wearaser™ holder (Collet) for use with vitrified or resilient Wearasers™
- Laser alignment guide



### Technical Specification

Part Number	Description
ST985750	Elcometer Taber® 5750 Linear Abraser (230V/115V, 50/60Hz)
Dimensions	208 x 228 x 279mm (20 x 9 x 11")
Weight	10kg (22lb)
Packing List	Elcometer Taber® 5750 Linear Abraser, Wearaser™ Collet and Spine Shaft, 3 x 250g (8.82oz) discs, 10 x CS-10 Wearasers™, 5 x H-18 Wearasers™, power cords (230V and 115V), allen key, Wearaser™ depth tool gauge, 50 x S-14 refacing strips, hand brush and operating instructions

Can be used in accordance with: (see Standards Explained inside Front Cover)

AATCC Method 8, ASTM D-2197, ASTM D-5178, ASTM D-6279, ASTM F1319, EN 2267-010, EN 3745-503, ISO Method 165, ISO 105-X12

### Accessories

ST131852	Wearaser™ Holder (collet) Kit - Aluminium*
ST131852-1	Wearaser™ Holder (collet) Kit - Plastic*
ST130575	Scratch Kit - Stainless Steel (includes conical diamond tool - 3mil and x7 measuring magnifier)
ST131604	ISO Scratch Kit - Aluminium (includes conical diamond tool - 3.5mil and x7 measuring magnifier)
ST121006	Conical Diamond Tool with 90°, 76.2µm (3 mils) Radius Point (for use with Scratch kit)
ST121006-1	Conical Diamond Tool with 90°, 88.9µm (3.5 mils) Radius Point (for use with Scratch kit)
ST131716-1	Coin Holder Attachment 45° (for use with Scratch Kit)
ST131716-2	Coin Holder Attachment 60° (for use with Scratch Kit)
ST131716-3	Coin Holder Attachment 75° (for use with Scratch Kit)
ST130570	Crockmeter Kit (includes finger, clamp ring and cloths)

\* For the complete range of Wearasers™, see page 78



## Elcometer Taber® 5135 & 5155 Rotary Abrasers

Used primarily in the testing of ceramics, plastics, textiles, metals, leather, rubber and painted, lacquered and electroplated surfaces, accelerated wear test procedures have also been written into many test specifications including ASTM, ISO, TAPPI and DIN - as well as automotive manufacturing procedures around the world.

The Taber® Rotary Abraser is an industry standard used in the wear and durability testing and is available with either a single test head or dual testing heads, which allows the user to test two different or identical materials simultaneously.

Choose from a wide variety of abrading wheels and abraser accessories to simulate real-life wear conditions - see page 78.

### Features :

- Platform speeds 60 and 72rpm
- Balanced, calibrated arms and wheel mounts
- Vacuum system with precision height adjustment
- Sealed aluminium housing with membrane control panel and digital display



### Technical Specification

Part Number	Description
UK/EUR 230V      US 115V	
<b>ST985135-2</b> <b>ST985135-1</b>	Elcometer Taber® 5135 Single Head Abraser*
<b>ST985155-2</b> <b>ST985155-1</b>	Elcometer Taber® 5155 Dual Head Abraser*
Dimensions & Weights	Elcometer Taber® 5135:    279 x 406 x 279mm (11 x 16 x 11")      19.5kg (43lb)
	Elcometer Taber® 5155:    482 x 355 x 279mm (19 x 14 x 11")      31.75kg (70lb)
	Vacuum unit:                    279 x 279 x 610mm (11 x 11 x 24")      10.0kg (22lb)
Packing List	Elcometer Taber® Abraser, auxiliary weights - 1 x 500g (17.64oz) load and 1 x 1000g (35.27oz) load, specimen holder 109.2mm (4.3") O/D (E-100-125), holding down ring (E-100-101), 100 x refacing discs (S-11), Calibrase® Wheel set (CS-10), Calibrade® Wheel set (H-18), vacuum unit with suction hose, round brush and operating instructions

*Can be used in accordance with: (see Standards Explained inside Front Cover)*

AATCC Method 8, ASTM C217, ASTM C241, ASTM C501, ASTM C1353, ASTM D1044, ASTM D-2197, ASTM D3389, ASTM D3384, ASTM D4060, ASTM D4158, ASTM D-5178, ASTM D5342, ASTM D5650, ASTM D-6279, ASTM F1319, ASTM F362, ASTM F510, ASTM F1478, DIN 52347, DIN 53109, DIN 53754, DIN 53799, DIN 68861T2, EN 2267-010, EN 3745-503, EN 438-2, FEDERAL TT-C-542, FEDERAL TT-E-487A, FEDERAL TT-P-85C, FEDERAL TT-P-87B, FEDERAL TT-P-918B, FEDERAL TT-P-95A, FEDERAL TT-P-141B, FTMS CCC-T-191 (Methods 5306 & 5309), FTMS GG-P-455B; ISO 5470, ISO 9352; ISO/DIS 3537, ISO/DIS 4586-2, ISO/DIS 7784-2, ISO Method 165, JISA1453, JIS K7204, JIS L-P-406 (Method 1091), JIS L-P-406 (Method 1091), JIS P8125, MILITARY MIL-A-8625, MILITARY MIL-C-13495A, MILITARY MIL-I-43553A, MILITARY MIL-M-13231C, MILITARY MIL-P-18493, MILITARY MIL-T-28800C, NF B51-282, SAE J365, SAE J948, SAE J1530, SIS 923509

### Accessories

\*For the complete range of Abrading wheels, please see page 78

## Taber® Abrading Wheels and Wearasers™

Taber® Abrading Wheels are available in five levels of abrasiveness to suit a wide range of material testing applications.

Wool, felt or plain rubber wheels test delicate materials or abrasiveness of materials such as dental powders.

Wheels featuring abrasive particles in a resilient matrix of rubber or a hard matrix of vitrified clay are suitable for stiffer materials.

- **Calibrase®:** resilient abrasive wheel - rubber and aluminium oxide
- **Calibrade®:** a non-resilient abrasive wheel - vitrified clay and silicon carbide
- **Plain Rubber:** contains no abrasive particles unless used with sandpaper strips
- **Tungsten Carbide:** severe cutting and tearing action with helical teeth for use on resilient materials such as rubber, leather and floor coverings



### Technical Specification

Part Number	Description	Abrasive Action	Composition
	Elcometer Taber™ 5135 and 5155 Rotary Abrasors (2 wheel set)		
ST125321	CS-10F Resilient Wheel (Pack of 2)	Very Mild	Rubber and Abrasive Grain
ST125320	CS-10 Resilient Wheel (Pack of 2)	Mild	Rubber and Abrasive Grain
ST125322	CS-17 Resilient Wheel (Pack of 2)	Harsh	Rubber and Abrasive Grain
ST125323	H-10 Non-resilient Wheel (Pack of 2)	Coarse	Vitrified Clay
ST125324	H-18 Non-resilient Wheel (Pack of 2)	Medium, Coarse	Vitrified Clay
ST125325	H-22 Non-resilient Wheel (Pack of 2)	Very Coarse	Vitrified Clay
ST125326	H-38 Non-resilient Wheel (Pack of 2)	Very Fine, Hard	Vitrified Clay
ST125344	CS-0, S-32 Resilient Wheel (Pack of 2)	Very Mild	Non-Abrasive Rubber
ST125564	Sand Paper Strips for use with CS-0,S-42	Medium	Sand Paper Strips (pack of 100)
ST121124	Sand Paper Strips for use with CS-0, S-42	Fine	Sand Paper Strips (pack of 100)
ST125319	CS-5 Resilient Wheel (Pack of 2)	None	Wool Felt
ST125345	S-35 Non-resilient Wheel (Pack of 2)	Severe Cutting	Tungsten Carbide
	Elcometer Taber™ 5750 Linear Abrader Wearaser™		
		Abrasive Action	Composition
ST130684	CS-10F Resilient Wearaser™ (pack of 10)	Very Mild	Rubber and Abrasive Grain
ST130685	CS-10 Resilient Wearaser™ (pack of 10)	Mild	Rubber and Abrasive Grain
ST130686	CS-17 Resilient Wearaser™ (pack of 10)	Harsh	Rubber and Abrasive Grain
ST130681	H-18 Non-resilient Wearaser™ (pack of 5)	Medium, Coarse	Vitrified Clay
ST130682	H-22 Non-resilient Wearaser™ (pack of 5)	Very Coarse	Vitrified Clay

## Elcometer Taber® 5135 & 5155 Accessories



### Multi-Media Attachment

Part Number: **ST985500**

This attachment is used to recreate contact surface wear caused by liquids, fluids and powders. Measure the abrasivity of materials including paints, pigments, adhesives, sealants, pastes, additives etc.

If you require either the Elcometer Taber® 5135 or Taber® 5155 ready assembled with the Multi-Media Attachment, please contact Elcometer.



### Grit Feeder Attachment

Part Number: Model 155 **ST980503-1**  
 Model 255 **ST980503-2**

Provides a unique method to evaluate 3-body abrasion resistance on a variety of materials. Aluminium oxide grit particles are evenly distributed on to the specimen wear path and pass under a pair of leather wheels. This loose grit acts as an abradant aiding the action that contributes to the physical breakdown of materials.

The Abraser Vacuum is attached to the grit feeder and continuously removes both abraded material and used grit.

The Grit distributor and vacuum removal nozzle heights are adjusted using a thumbscrew.

Two versions are available, Model 155 and Model 255. The Model 155 uses an alignment guide screw to set the position of the instrument. An alignment block is incorporated into the base of Model 255, to ensure the correct location of the grit feeder in relation to the Abraser.

Both models are supplied complete with:

- S-39 Leather wheel set
- S-41 #240 Aluminium oxide
- S-38 Standardisation Plates
- Alignment guide and mounting hardware



### Sample Cutter

Part Number: **ST985000**

The Model 5000 Sample Cutter will cut precise 106mm (4.2") circular sample with a 6.35mm (0.25") centre hole to prepare your specimens for use with the Elcometer Taber® Abrasers.

An easy counter-clockwise cutting motion allows you to cut a variety of materials. Optional pads, which allow cutting thicknesses of 0.03mm (0.001") to 6.35mm (0.25"), are also available.

## Elcometer Taber® 5135 & 5155 Accessories



### Quiet Cabinet

Part Number:

**ST129497**

Complete 230V - both upper and base cabinets

**ST128372**

Complete 115V - both upper and base cabinets

**ST129498**

Base unit only 230V - includes vacuum unit

**ST128371**

Base unit only 115V - includes vacuum unit

**ST128370**

Upper unit only - work space and viewing window

Comprising an upper and lower unit, this solid wood cabinet is suitable for use in a laboratory environment and achieves an approximate 20% reduction in operating sound level.

The top cabinet provides a convenient, dust-free work space for the Abraser and features a Plexiglas® viewing window to monitor testing and removable front for easy transfer of the Abraser in and out of the cabinet.

The base cabinet holds the Abraser Vacuum Unit and includes an inbuilt exhaust system for effective air circulation.

Both cabinets offer ample room to store test specimens, supplies and accessories.

The Quiet Cabinet can be purchased as a complete unit or the top and base separately. The lower cabinet exhaust system is available for 230V/50Hz or 115V/60Hz.

### Calibration Verification Kit

Part Number:

**ST132030**

A cost effective method that enables users to verify that an instrument is in calibration, or requires attention. Each kit is individually calibrated providing a reliable check system.

Kit allows you to verify:

- Longitudinal alignment of abraser arm
- Transverse alignment of abraser arm
- Wheel tracking and wear pattern
- Bearing integrity (tracking pattern compliance)
- Vacuum nozzle orifice size
- Minimum vacuum nozzle suction force
- S-30 Weartrac precision wheels (x1 set)

Supplied complete with:

- S-45 Wheel tracking cards (x15)
- Vacuum nozzle suction and orifice gauge
- Vacuum nozzle O-ring
- Dual unit vacuum plug
- Taber® Abraser clean-up hose



## Elcometer 1730 Car Wash Simulator

This unique, affordable abraser is designed to simulate the accelerated abrasion caused by automatic car washers around the world.

The sample to be tested is held at a predetermined angle and subjected to the rotating action of the abrasive fibres. Once the cycle speed and number of rotations has been set, the instrument simulates the effect of abrasion by the fibres in either wet or dry conditions.

A reservoir, complete with integrated stirring paddles, provides a means to test the abrasive effect of solutions, detergents and contaminants. The peristaltic pump and compressed air feed ensures a controlled flow of liquid is distributed uniformly across the test sample.

The effect of the abrasion can be quantified by measuring the change in gloss using a glossmeter. For information on glossmeters see page 108 - 112.

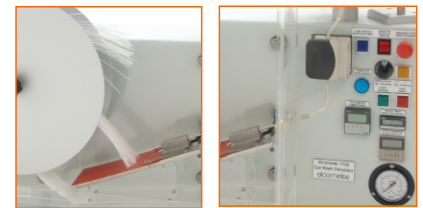
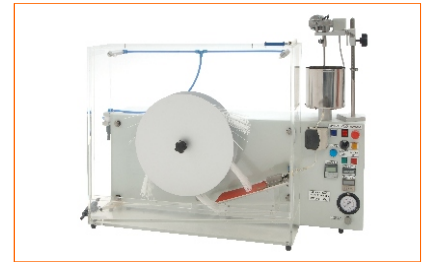

Complying with the relevant standards and test methods of Peugeot-Citroën (PSA), Renault-Nissan, Fiat, Lancia and Alfa-Romeo, the Elcometer 1730 Car Wash Simulator can be used to test coatings, plastics, glass, rubber and all other external vehicle body components.

- Self-contained, desktop unit with door open safety cut-off
- Test sample is visible at all times during the test cycle with integrated cabinet-cleaning water jets
- Fully adaptable for a wide range of carwash fibres and other materials
- The effect of a wide range of solvents and abrasive mixtures simulating real life conditions
- Automatic stop upon completion of predetermined cycle count
- Rapid sample replacement fixture
- Clear and easy to use control system

### Technical Specification



Part Number	Description	
UK/EUR 230V	US 110V	
<b>K0001730M002</b>	<b>K0US1730M002</b>	Elcometer 1730 Car Wash Simulator
Dimensions	1100 x 800 x 500mm (43 x 31.5 x 20")	
Weight	80kg (176lb)	
Packing List	Elcometer 1730, abrasive solution tank, flexible tube for peristaltic pump, one set of fibres, fibre cutting tube with cutter, mains lead and operating instructions	

### Accessories

<b>KT001730P307A</b>	Slide Support for Fibres
<b>KT001730P601A</b>	Calibrated Tube for Cutting Fibres to Length
<b>KT001730P602</b>	Fibre Fixing Collar
<b>KT001730P016</b>	PSA Fibres: Length 900mm (35.4"); Approximately 3000 fibres

## Elcometer 1700 Falling Sand Tester

The Falling Sand tester is a rugged and sturdy instrument, used to measure the resistance to abrasion of paints and lacquers.

Standardised sand is contained in a hopper which is connected to a guide tube. Test pieces are fixed at a 45° angle, 25mm (0.98") from the base of the tube, where the wear can be observed.

The sand is allowed to fall, at a controlled rate, on to the test piece which must have a known coating thickness.

The resistance to abrasion is measured when the substrate is revealed and measured by the amount of sand required to wear through the coating.



### Technical Specification

**C** certificate available

Part Number	Description
<b>K0001700M001</b>	Elcometer 1700 Falling Sand Tester
Dimensions	1790 x 330 x 400mm (70 x 12.9 x 15.7")
Weight	20kg (44lb)
Packing List	Elcometer 1700 Falling Sand Tester and operating instructions

*Can be used in accordance with: (see Standards Explained inside Front Cover)*

**ASTM D 968-A, DIN 53233, FTMS 141 6191, JIS A1452**

### Accessories

<b>KT001700N001</b>	Ottawa ASTM Standardised Sand - 23kg (50.7lb)
<b>KT001700N002</b>	CEN DIN EN 196-1 Standardised Sand - 50kg (110lb)
<b>KT001700N003</b>	Artificial Corundum - NF Standard Bag - 5kg (11lb)
<b>KT001700P001</b>	Glass Tube for Falling Sand Tester

## Hardness Testing

Hardness can be defined as a material's resistance to permanent deformation.

In the coatings industry, hardness measurement can be used to determine the resistance of the coating to scratching from general wear and tear and also if a coating is fully cured.

The term "Hardness" is used to refer to different properties of material, specifically:

- Resistance to scratch and wear
- Resistance to penetration

Depending on the requirements, there are various methods for testing hardness. Some are dedicated to characterise coatings and others are more suitable for testing bulk materials such as metals, plastics, rubber or elastomers.

### **Resistance to Scratch and Wear Method:**

To assess a coating's resistance to scratch there are a number of different instruments that can be used:

- Pencil Hardness Tester - marking
- Sclerometer - scratch
- Clemen Apparatus - scratch/indentation
- Scratching and Shearing Instrument - scratch
- Pendulum Hardness - amplitude

### **Resistance to Indentation Method:**

There are many instruments available to assess the resistance to penetration. For coatings in particular, there are three common methods where the depth of penetration of a weighted tool is used to show the coating's resistance to penetration:

- Buchholz
- Barcol
- Shore



## Elcometer 501 Pencil Hardness Tester

The pencil hardness test, also referred to as the Wolff-Wilborn test, uses the varying hardness values of graphite pencils to evaluate a coating's hardness.

The Elcometer 501 has been designed to ensure that the cylindrical pencil lead is maintained at a constant angle of 45° and exerts a force of 7.5N (1.68lbF).

The pencil lead, prepared beforehand using the special sharpener and abrasive paper, is inserted into the Elcometer 501 and pushed over the smooth, flat coated surface. The lowest hardness value of the pencil which marks the coating determines the coating's hardness rating.



### Technical Specification

certificate available

Part Number	Description
<b>H501-----1</b>	Elcometer 501 Pencil Hardness Tester
Dimensions (with Pencils)	130 x 130 x 50mm (5 x 5 x 2")
Weight	2.1kg (4lb)
Packing List	Elcometer 501 Pencil Hardness Tester, pencil set (14 pencils, grades 6B - 6H), positioning block, x2 pencil sharpener, abrasive paper block, carry case and operating instructions

Can be used in accordance with: (see Standards Explained inside Front Cover)

AS 3894.4, ASTM D 3363, AS/NZS 1580.405.1, BS 3900 E19, ECCA T4, EN 13523-4, ISO 15184

### Accessories

<b>T501190451</b>	Pencil Sharpener (6H to 2B)		
<b>T501190452</b>	Pencil Sharpener (3B to 6B)		
<b>T50115771</b>	Set of 14 Pencils (6B to 6H)		
<b>KT003080P001</b>	12 Hardness Pencils (6B)	<b>KT003080P008</b>	12 Hardness Pencils (F)
<b>KT003080P002</b>	12 Hardness Pencils (5B)	<b>KT003080P009</b>	12 Hardness Pencils (H)
<b>KT003080P003</b>	12 Hardness Pencils (4B)	<b>KT003080P010</b>	12 Hardness Pencils (2H)
<b>KT003080P004</b>	12 Hardness Pencils (3B)	<b>KT003080P011</b>	12 Hardness Pencils (3H)
<b>KT003080P005</b>	12 Hardness Pencils (2B)	<b>KT003080P012</b>	12 Hardness Pencils (4H)
<b>KT003080P006</b>	12 Hardness Pencils (B)	<b>KT003080P013</b>	12 Hardness Pencils (5H)
<b>KT003080P007</b>	12 Hardness Pencils (HB)	<b>KT003080P014</b>	12 Hardness Pencils (6H)



## Elcometer 3086 Motorised Pencil Hardness Tester

Traditional pencil hardness testers can be limited in their reproducibility and repeatability by two key factors; the uniformity of the carriage speed and the variation of the applied force by the user as the manual tester is moved across the coating.

The Elcometer 3086 Motorised Pencil Hardness Tester, using the same test methods and principles as the Elcometer 501 pencil hardness tester, removes both of these variables by being fully independent. The internal motor drives the unit at a constant, uniform speed across the coated surface, exerting a fixed, user determined force between 0 - 10N (0 - 2.25lbf)

Using the pencil lead holder, pencil leads of varying hardness values can be quickly interchanged to determine a coating's hardness rating.

Manufactured from anodised aluminium, the Elcometer 3086 can travel forwards (chip method) or backwards (indentation method), as required.



### Technical Specification

 certificate available

Part Number	Description		
UK 240V	EUR 220V	US 110V	
<b>K0UK3086M001</b>	<b>K0003086M001</b>	<b>K0US3086M001</b>	Elcometer 3086 Motorised Pencil Hardness Tester
Dimensions	280 x 140 x 240mm (11 x 5.5 x 9.4")		
Weight	3.8kg (8.4lb)		
Packing List	Elcometer 3086, lead holder, lead set (14 cases of leads, grades 6H to 6B, 12 leads per case), positioning block, abrasive sharpener, abrasive paper and operating instructions		
<i>Can be used in accordance with: (see Standards Explained inside Front Cover)</i>			
<b>ASTM D 3363, AS/NZS 1580.405.1, BS 3900 E19, EN 13523-4, ISO 15184</b>			

### Accessories

<b>KT003084P020</b>	Spare Lead Holder		
<b>KT003084P001</b>	12 Hardness Leads (6B)	<b>KT003084P008</b>	12 Hardness Leads (F)
<b>KT003084P002</b>	12 Hardness Leads (5B)	<b>KT003084P009</b>	12 Hardness Leads (H)
<b>KT003084P003</b>	12 Hardness Leads (4B)	<b>KT003084P010</b>	12 Hardness Leads (2H)
<b>KT003084P004</b>	12 Hardness Leads (3B)	<b>KT003084P011</b>	12 Hardness Leads (3H)
<b>KT003084P005</b>	12 Hardness Leads (2B)	<b>KT003084P012</b>	12 Hardness Leads (4H)
<b>KT003084P006</b>	12 Hardness Leads (B)	<b>KT003084P013</b>	12 Hardness Leads (5H)
<b>KT003084P007</b>	12 Hardness Leads (HB)	<b>KT003084P014</b>	12 Hardness Leads (6H)

## Elcometer 3080 Pencil Hardness Tester

This is a simple and effective technique to evaluate the hardness of many coatings.

The pencil lead, prepared beforehand by using the special pencil sharpener and rubbing it on fine abrasive paper (400 grade), is maintained at an angle of 45° and pushed with uniform pressure on to the sample, leaving either a superficial trace or causing destruction down to the substrate.

The Elcometer 3080 Pencil Hardness Test is supplied complete with stand and a series of 14 pencils, ranging from 6B to 6H hardness values.



### Technical Specification

Part Number	Description
<b>K0003080M003</b>	Elcometer 3080 6B to 6H Pencil Hardness Test with Stand
Dimensions	330 x 280 x 330mm (13 x 11 x 13")
Weight	1kg (2.2lb)
Packing List	Set of 14 pencils - 6B to 6H, x2 pencil sharpeners, storage stand, operating instructions
<i>Can be used in accordance with: (see Standards Explained inside Front Cover)</i>	
<b>AS 3894.4, ASTM D 3363, AS/NZS 1580.405.1, BS 3900-E19, ECCA T4, EN 13523-4, ISO 15184</b>	

### Accessories

<b>T501190451</b>	Pencil Sharpener (6H to 2B)		
<b>T501190452</b>	Pencil Sharpener (3B to 6B)		
<b>T50115771</b>	Set of 14 pencils (6B to 6H)		
<b>KT003080P001</b>	12 Hardness Pencils (6B)	<b>KT003080P008</b>	12 Hardness Pencils (F)
<b>KT003080P002</b>	12 Hardness Pencils (5B)	<b>KT003080P009</b>	12 Hardness Pencils (H)
<b>KT003080P003</b>	12 Hardness Pencils (4B)	<b>KT003080P010</b>	12 Hardness Pencils (2H)
<b>KT003080P004</b>	12 Hardness Pencils (3B)	<b>KT003080P011</b>	12 Hardness Pencils (3H)
<b>KT003080P005</b>	12 Hardness Pencils (2B)	<b>KT003080P012</b>	12 Hardness Pencils (4H)
<b>KT003080P006</b>	12 Hardness Pencils (B)	<b>KT003080P013</b>	12 Hardness Pencils (5H)
<b>KT003080P007</b>	12 Hardness Pencils (HB)	<b>KT003080P014</b>	12 Hardness Pencils (6H)

## Elcometer 3092 Sclerometer Hardness Tester

The Elcometer 3092 tests the hardness of a coating by moving a Tungsten Carbide Tip over the coating with predetermined force.

The body of the instrument contains a cursor fitted with a screw lock and a round tip, compressed by one of the four springs corresponding to the four printed scales:

- *Grey spring:* 0-3N (0.671lbF)
- *Red spring:* 0-10N (2.248lbF)
- *Blue spring:* 0-20N (4.49lbF)
- *Green spring:* 0-30N (6.74lbF)



The spring force can be set by the “collar”; compressing the spring increases the force with which the tip is pushed on to the surface of the test piece. By making short, straight movements while gradually increasing the load, the user can observe the force at which the tip leaves a mark or destroys the coating.

Each Elcometer 3092 is supplied in a case with a 0.75mm (0.03”) diameter tungsten carbide tip and 3 springs (grey, red and blue). An optional green spring of 0 - 30N is also available.

### Technical Specification

<b>K0003092M201</b>	Elcometer 3092 Sclerometer Hardness Testers - 3 ranges
Dimensions	165 x 24 x 16mm (6.5 x 1 x 0.6")
Weight	370g (13oz)
Packing List	Elcometer 3092 Sclerometer, tool with 0.75mm (0.03") diameter tungsten carbide tip, 3 springs (grey, red and blue), carry case and operating instructions
<i>Can be used in accordance with: (see Standards Explained inside Front Cover)</i>	
<b>AS 3894.4, EN 438-2, ISO 4586-2</b>	

### Accessories

<b>KT003092P001</b>	0.5mm (0.02") Tungsten Carbide Tip
<b>KT003092P002</b>	0.75mm (0.03") Tungsten Carbide Tip
<b>KT003092P003</b>	1.0mm (0.04") Tungsten Carbide Tip
<b>KT003092P008</b>	90° Diamond Point Cone, 90µm (3.54mils) Radius - ISO Type
<b>KT003092P004</b>	Grey Spring 0 - 3N (0 - 0.671lbF)
<b>KT003092P005</b>	Red Spring 0 - 10N (0 - 2.248lbF)
<b>KT003092P006</b>	Blue Spring 0 - 20N (0 - 4.49lbF)
<b>KT003092P007</b>	Green Spring 0 - 30N (0 - 6.74lbF)

## Elcometer 3000 Manual Clemen Unit

Designed to evaluate resistance to scratching, a tool is fitted with an hemispherical end of 1mm (0.04") diameter (standard), lowered gradually on to the surface of the sample and moved 60mm (2.36"). The sample width must be approximately 75mm (2.95").

Depending on the load applied, varying degrees of penetration of the tool into the coating are observed, from a superficial trace to total destruction.

As the sample is pulled by hand, the tool lowers on to the sample, moves along it and gently rises up.

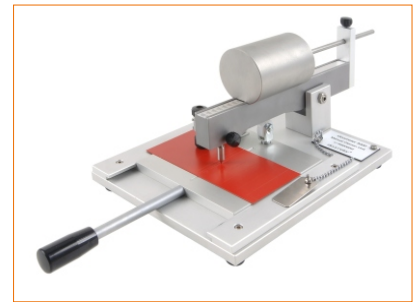

### Technical Specification

certificate available

Part Number	Description
K0003000M001	Elcometer 3000 Manual Clemen Unit
Dimensions	Manual: 410 x 200 x 155mm (16.1 x 7.9 x 6.1")
Weight	6kg (13.2lb)
Packing List	Elcometer 3000 Clemen Unit, 1kg (35.27oz), 1mm (0.04") ball tool and operating instructions
<i>Can be used in accordance with: (see Standards Explained inside Front Cover)</i>	
ISO 4586-2, EN 438-2	

### Accessories

KT003000P021	1mm (0.04") Ball Tool in Tungsten Carbide
KT003000N001	2mm (0.08") Cutting Tool in Tungsten Carbide
KT003000N013	VW Cutting Tool
KT003000N002	1cm <sup>2</sup> (0.15 inch <sup>2</sup> ) Rubber Tool (to be used as a guide to the dryness of a sample)
KT003000N015	Adjustment Kit to test from 5 to 20mm (0.02 to 0.8")
KT007210M001	Illuminated Microscope (x30)
KT001546N002	Cross Cut Magnifying Glass

## Elcometer 3000 Motorised Clemen Unit

Using the same principles as the Elcometer 3000 Manual Clemen Unit, the motor brings the tool gently in contact with the sample, whatever the load, variable from 0 to 5000g (176.4oz), moves across the coating and then gently lifts it with the automatic Start/Stop function.

The contact of the tool with the metallic substrate is indicated by a lamp and voltmeter. This unit has a significant benefit over the manual version as more repeatable and reproducible results can be obtained due to the uniformity of both speed and movement.



### Technical Specification

**C** certificate available

Part Number	Description
<b>K0003000M003</b>	Elcometer 3000 Motorised Clemen Unit (UK 240V/EUR 220V)
<b>K0US3000M003</b>	Elcometer 3000 Motorised Clemen Unit (US 110V)
Dimensions	Motorised: 460 x 280 x 330mm (18 x 11 x 13")
Weight	20kg (44lb)
Packing List	Elcometer 3000 Clemen Unit, 1kg (35.27oz) x4 weights, 1mm (0.04") ball tool and operating instructions

*Can be used in accordance with: (see Standards Explained inside Front Cover)*

**ISO 4586-2, EN 438-2**

### Accessories

<b>KT003000P021</b>	1mm (0.04") Ball Tool in Tungsten Carbide
<b>KT003000N001</b>	2mm (0.08") Cutting Tool in Tungsten Carbide
<b>KT003000N013</b>	VW Cutting Tool
<b>KT003000N002</b>	1cm <sup>2</sup> (0.15 inch <sup>2</sup> ) Rubber Tool (to be used as a guide to the dryness of a sample)
<b>KT003000N015</b>	Adjustment Kit to test from 5 to 20mm (0.02 to 0.8")
<b>KT007210M001</b>	Illuminated Microscope (x30)
<b>KT001546N002</b>	Cross Cut Magnifying Glass

## Elcometer 3025 Scratch/Shear Tester

The Elcometer 3025 is a motorised device to test the resistance of many materials to scratching, shearing, gouging, marring, scraping and engraving. This portable instrument tests materials up to 12.7mm (½") thick by 101mm (4") square or round.

The height of the scale beam is adjusted by the user to match the thickness of the sample. The tool, a conical diamond tip, is then placed on the sample and the instrument is activated by the user with the On/Off switch.

The tip leaves a trace mark and the extent of this, in relation to the load used, indicates the degree of hardness. The turntable rotates at a constant 5rpm to ensure repeatability and reproducibility of tests. By changing the load on the tool, from 0 - 1000g (0 - 2.2lb), the sample's resistance to deformation can be evaluated.



### Technical Specification

Part Number	Description	
UK 240V	EUR 220V	US110V
<b>K0UK3025M001</b>	<b>K0003025M001</b>	<b>K0US3025M001</b>
Dimensions	Elcometer 3025 Scratch/Shear Tester	
Weight	445 x 190 x 150mm (17 x 7.8 x 6")	
Packing list	6.8kg (14.9lb)	
Elcometer 3025 and operating instructions		
<i>Can be used in accordance with: (see Standards Explained inside Front Cover)</i>		
ISO 4586-2		

### Accessory - Sample Cutter



The Sample Cutter cuts precise 106mm (4.2") circular samples with a 6.35mm (0.25") centre hole to prepare specimens for use with the Taber® Abrasers.

An easy counter-clockwise cutting motion allows the user to cut a variety of materials. Optional pads allowing cutting thicknesses of 0.03mm (0.001"), 4.74mm (0.187") and 6.35mm (0.25") are available.

### Accessories

<b>ST985000</b>	Sample Cutter
<b>ST131569</b>	Sample Cutter Upper Pad – 4.74mm (0.187")
<b>ST131570</b>	Sample Cutter Upper Pad – 6.36mm (0.250")
<b>KT003025P007</b>	Magnifier (x10)

## Elcometer 3030 & 3040 Persoz & König Pendulum Hardness Testers

Consisting of a pendulum which is free to swing on two balls resting on a coated test panel, these pendulum hardness testers are based on the principle that the amplitude of the pendulum's oscillation decreases more slowly when supported on a harder surface.

The hardness of any given coating is given by the number of oscillations within the specified limits of amplitude. This is determined by accurately positioned photo sensors. An inbuilt levelling bubble ensures the tester is correctly positioned, an electronic counter records the number of swings made by the pendulum and a hood - fitted with a front door and a side opening to simplify sample handling - protects against draughts.

The Persoz and König methods differ by the dimensions, period and amplitude of the oscillation.

- The Persoz test measures the time taken for the amplitude of oscillation to decrease from 12° to 4° whereas the König measures from 6° to 3°



### Standard equipment:

- Practical system to facilitate sample tightening and loading of pendulum, with automatic release
- Maximum sample dimensions: 200 x 110 x 15mm (7.85 x 4.33 x 0.6")
- Accurate, automatic counting by photoelectric cell



#### PERSOZ METHOD

Stainless steel pendulum, weight 500g (17.6oz.), fitted with 2 balls measuring 8mm (0.3") diameter.

Oscillation Period: 1 second, ± 0.001  
 Deflections: 12° to 4°  
 Damping Time on Glass: 430 ± 10 seconds



#### KÖNIG METHOD

Stainless steel pendulum, weight 200g (7.05oz.), fitted with 2 balls measuring 5mm (0.2") diameter.

Oscillation Period: 1.4 seconds, ± 0.02  
 Deflections: 6° to 3°  
 Damping Time on Glass: 250 ± 10 seconds

### Technical Specification

**C** certificate available

Part Number	Description	
UK/EUR 230V	US 110V	
<b>K0003030M002</b>	<b>K0US3030M002</b>	Elcometer 3030 Persoz Pendulum Hardness Tester
<b>K0003040M002</b>	<b>K0US3040M002</b>	Elcometer 3040 König Pendulum Hardness Tester
<b>K0003034M001</b>	<b>K0US3034M001</b>	Elcometer 3034 Persoz and König Pendulum Hardness Tester
Dimensions	825 x 460 x 410mm (32.5 x 18 x 16")	
Weight	23kg (50lb)	
Packing List	Elcometer Pendulum Hardness Tester, Persoz pendulum (Persoz tester only), König pendulum (König tester only), glass calibration certificate, set of adjustment shims for sensor bracket, from 0.03 to 1mm (0.001 to 0.004"), mains lead and operating instructions	

Can be used in accordance with: (see Standards Explained inside Front Cover)

ASTM D 4366, BS 3900 E5, DIN 53157, **ISO 1522**, NBN T22-105, NFT 30 016

### Accessories

<b>KT003030P001</b>	Persoz Pendulum
<b>KT003040P001</b>	König Pendulum
<b>KT003045P009</b>	Glass Calibration Plate

## Elcometer 3095 Buchholz Hardness Tester

Measuring a coating's hardness using the indentation method, the Elcometer 3095 Buchholz Hardness Tester consists of a bevelled disc indenting tool which is fitted into a stainless steel block exerting a constant test load of 500g (17.6oz).

The gauge is placed on to the coating for 30 seconds and the length of any subsequent indentation in the coating is measured using the graduated microscope. The result is expressed as units of Buchholz Indentation resistance using the scale printed in the operating instructions.



### Technical Specification

**C** certificate available

Part Number	Description
<b>K0003095M001</b>	Elcometer 3095 Buchholz Hardness Tester
Dimensions	360 x 310 x 120mm (14.2 x 12.2 x 4.7")
Weight	2.9kg (6.4lb)
Packing List	Elcometer 3095 Buchholz Hardness Tester, indentation tool with bevelled disc and two locating pins, pin adjusting shim, x20 illuminated microscope, indentation locator template, hexagonal wrench, plastic carry case and operating instructions

*Can be used in accordance with: (see Standards Explained inside Front Cover)*

BS 3900 E9, DIN 53153, **ISO 2815**, NFT 30-052

### Accessories

<b>KT003095P001</b>	Spare Pin Supports (x2)
<b>KT003095P002</b>	Bevelled Hardened Steel Disc Indenter

### Measure of Buchholz Hardness

Indentation Depth		Indentation Resistance	Indentation Depth		Minimum coating thickness for which a measurement is valid	
µm	mm		µm	mils	µm	mils
20	0.8	125	5	0.2	15	0.59
21	0.85	118	6	0.24	20	0.79
23	0.9	111	7	0.28	20	0.79
24	0.95	105	7	0.28	20	0.79
25	1.0	100	8	0.31	20	0.79
38	1.05	95	9	0.35	20	0.79
28	1.1	91	10	0.39	20	0.79
29	1.15	87	11	0.43	25	1
30	1.2	83	12	0.47	25	1
33	1.3	77	14	0.55	25	1
35	1.4	71	16	0.63	30	1.18
38	1.5	67	18	0.71	30	1.18
41	1.6	63	21	0.83	35	1.38
43	1.7	59	24	0.94	35	1.38



## Elcometer 3120 Shore Durometer

The Elcometer 3120 range of durometers is widely used to test the hardness of soft materials. A round point indents the material under a fixed force spring and the hardness is displayed on the dial in Shore Hardness Units.

The instrument can be either hand held or fitted to an optional stand for increased repeatability.

*The Elcometer 3120 range of Shore Durometers encompasses a number of hardness values. Please refer to the table below.*



### Technical Specification

**C** certificate available

Part Number		Description
Without certificate	With certificate	
K0003120M001	K0003120M015	Elcometer 3120 Shore Durometer A
K0003120M008	-	Elcometer 3120 Shore Durometer A with Max indicator
-	K0003120M025	Elcometer 3120 Shore Durometer A with Max indicator and 12.5N weight
K0003120M003	K0003120M016	Elcometer 3120 Shore Durometer B
K0003120M204	-	Elcometer 3120 Shore Durometer B with Max indicator
K0003120M004	K0003120M017	Elcometer 3120 Shore Durometer C* - see below
K0003120M205	-	Elcometer 3120 Shore Durometer C* with Max indicator - see below
K0003120M005	K0003120M018	Elcometer 3120 Shore Durometer D* - see below
K0003120M009	-	Elcometer 3120 Shore Durometer D* with Max indicator - see below
K0003120M010	-	Elcometer 3120 Shore Durometer DO* - see below
K0003120M208	-	Elcometer 3120 Shore Durometer DO* with Max indicator - see below
K0003120M006	K0003120M019	Elcometer 3120 Shore Durometer O
K0003120M207	-	Elcometer 3120 Shore Durometer O with Max indicator
K0003120M221	K0003120M222	Elcometer 3120 Shore Durometer OO and 400g (14.11oz) mass
K0003120M024	-	Elcometer 3120 Shore Durometer OOO and 400g (14.11oz) mass
Dimensions		50 x 50 x 110mm (1.9 x 1.9 x 4.3")
Weight		300g (10.58oz)
Packing list		Elcometer Shore Durometer and operating instructions. A Check Piece is supplied with Elcometer Shore Durometers A and D

\* In order to avoid any damage to the indenters a control ring is required. Please order part number KT003120N004

Can be used in accordance with: (see Standards Explained inside Front Cover)

ASTM D 2240, DIN 53505, ISO 868, ISO 7267-2, NFT 51109

## Accessories

KT003120N002	Test Stand and 12.5N Load Shore A, B and O
KT003120P005	50N Load Shore D, C and DO for Test Stand BS61 (to be used with KT003120N002)
KT003120N203	Test Stand and 400g (14.11oz) Mass Shore OO and OOO
KT003120N004	Control Ring 40 Shore

## Material Relative Hardness Range

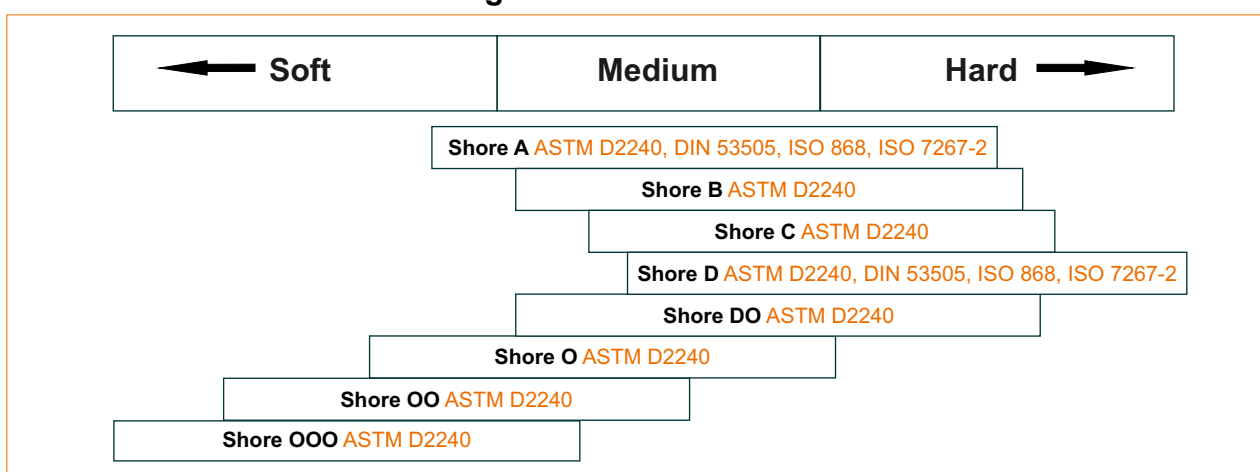

Customers who purchased the Elcometer 3120 also purchased:



◀ Elcometer 1506  
Cylindrical Bend Tester,  
page 99

Elcometer 1542 Cross  
Hatch Adhesion Tester,  
page 218 ▶



## Elcometer 3101 Barcol Impressor Hardness Tester

These easy to use hardness testers are ideal for testing the hardness of soft metals, plastics, fibreglass and leather.

Making sure the indenter point is perpendicular to the surface being tested, the instrument is placed onto the sample and a light pressure is exerted against the instrument driving the spring-loaded indenter point into the material and the hardness reading is instantly indicated on the dial. No waiting, pre-loading or separate measurements are required.

There are three models in the range:

*Elcometer 3101/1* Model 934-1: for soft metals such as aluminum and its alloys, brass, copper, and some of the harder plastics and fibreglass. Approximate range 25 to 150 Brinell (10 mm ball, 500 kg load). This unit meets ASTM Standard D2583.

*Elcometer 3101/2* Model 935: for softer plastics and very soft metals

*Elcometer 3101/3* Model 936: for extremely soft materials such as lead, linoleum and leather



To ensure the Barcol Hardness Tester is in calibration, a range of Standard Test Discs is available. Please select the appropriate Test Disc from the list of Accessories below to supplement the disc supplied.

All results are recorded in Barcol Units (BU).

### Technical Specification

Part Number	
K0003101M001	Elcometer 3101/1 Barcol Hardness Tester Type 934/1 at 25-150 Brinell Hardness
K0003101M002	Elcometer 3101/2 Barcol Hardness Tester Type 935 at 50-100 Rockwell
K0003101M003	Elcometer 3101/3 Barcol Hardness Tester Type 936
Dimensions	152 x 106 x 50mm (6 x 4 x 2")
Weight	900g (2lb)
Packing List	Elcometer 3101, adjusting spanner, 2 x indenting points, appropriate standard test disc and operating instructions

*Can be used in accordance with: (see Standards Explained inside Front Cover)*

AS 3894.4, ASTM B 648, ASTM D 2583, NFT 38-501

### Accessories

KT003101P001	Spare Indenter point for Elcometer 3101/1 and Elcometer 3101/2
KT003101P006	Spare Indenter point for Elcometer 3101/3
KT003101P202	Standard Test Disc 934-1; 87 - 89 BU
KT003101P002	Certified Test Disc 934-1; 87 - 89 BU (Pack of 5)
KT003101P203	Standard Test Disc 934-1; 43 - 48 BU
KT003101P003	Certified Test Disc 934-1; 43 - 48 BU (Pack of 5)
KT003101P204	Standard Test Disc 935; 87 - 89 BU
KT003101P004	Certified Test Disc 935; 87 - 89 BU (Pack of 5)
KT003101P205	Standard Test Disc 936; 48 - 50 BU
KT003101P005	Certified Test Disc 936; 48 - 50 BU (Pack of 5)

## Elcometer 1537 ISO Scratching Tool

The Elcometer 1537 ISO Scratching Tool is a simple but effective instrument which is used to scratch the surface of samples in preparation for adhesion, salt spray and corrosion tests. The tool is held horizontally and pulled across the sample to produce the scratch.

The Elcometer 1537 has a tungsten carbide blade which is set to give a 90° cutting angle with a 75° cutting edge.



### Technical Specification

**C,A** certificate available

Part Number	Description
<b>K0001537M001</b>	Elcometer 1537 ISO Scratching Tool
Dimensions	200 x 45 x 20mm (7.8 x 1.7 x 0.8")
Weight	100g (3.5oz)
Packing List	Elcometer 1537 ISO Scratching Tool, storage case, operating instructions
<i>Can be used in accordance with: (see Standards Explained inside Front Cover)</i>	
<b>ISO 2063</b>	

## Elcometer 1538 DIN Scratching Tool

The Elcometer 1538 has interchangeable carbide cutters for the preparation of specimens to be used for corrosion testing. Supplied complete with a 0.5mm (0.02") or 1mm (0.04") cutter.

A Renault-version of the tool (a blade adjustment device ensures accurate settings) is also available.



### Technical Specification

**C,A** certificate available

Part Number	Description
<b>K0001538M201</b>	Elcometer 1538 DIN Scratching Tool with 1mm (0.04") Cutter - CASS Test
<b>K0001538M202</b>	Elcometer 1538 DIN Scratching Tool with 0.5mm (0.02") Cutter - Salt Spray Test
<b>K0001538M004</b>	Elcometer 1538 DIN Scratching Tool with 0.5mm (0.02") Cutter - Renault Version
<b>K0001538M005</b>	Elcometer 1538 DIN Scratching Tool with 1mm (0.04") Cutter - Renault Version
Weight	113g (4oz)
Packing List	1538 DIN Scratching Tool, hexagonal wrench, cutter, storage case, operating instructions
<i>Can be used in accordance with: (see Standards Explained inside Front Cover)</i>	
DIN 53167, DIN 50021	

### Accessories

<b>KT001538N003</b>	Spare 0.5mm (0.02") Cutter
<b>KT001538N201</b>	Spare 1mm (0.04") Cutter

## Elasticity & Resistance to Deformation

The performance of coatings when influenced by external stresses caused by stretching, bending or impacts, determines their suitability for their designed application.

A coating designed for use in the coil coating industry, for example, should have the ability to stretch as the substrate is formed into its desired shape without damage. Deformation or damage would reduce the protective quality and appearance including colour change, adhesion etc.

Further, a coating designed for industrial use should be able to withstand impacts during the life of the product.

In order to characterise a coating's performance to elongation and deformation, a number of repeatable and reproducible tests have been developed.

### ▪ **Mandrel Bend Test**

A coated metal sheet is bent over a conical or cylindrical mandrel and cracks, colour change, adhesion etc. of the coating are evaluated. Corresponding results, produced by decreasing mandrel sizes, indicate the degree of elasticity of the coating.

A conical mandrel allows the user to undertake fewer tests to achieve a similar result to cylindrical mandrels.

### ▪ **Cupping Test**

A coated metal sheet is subjected to a gradual deformation by a polished die being pushed from beneath the coating - i.e. from the reverse side of the sheet.

### ▪ **Variable Impact Tests**

There are two methods: either a weight with a punch attached falls on a coated metal sheet or a weight falls on to a punch which is resting on the coated metal sheet. In either test, the damage caused is observed and evaluated. These methods are used to identify how the coating performs under a rapid deformation process.



## Elcometer 1510 Conical Mandrel Bend Tester

The 1510 Bend Tester is a mechanical tester used to determine the effects of bending on the elasticity, adhesion and elongation properties of cured coatings on sheet metal.

The frame has a bending lever with a roller which pivots on a steel conical mandrel with a diameter from 3.2 - 38.1mm (0.12 - 1.5"). A graduation indicates the mandrel diameter in both mm and inches.

The specimen can be bent on part of, or along, the entire length of the mandrel, and the results (cracks) corresponding to different test diameters can be observed in a single operation. This is ideal for use in conjunction with the cylindrical mandrel, as it identifies the stop point for more focused testing

As the instrument is machined out of a solid block of steel, the particularly robust and rigid construction provides excellent resistance to wear and provides long service life. A large, sturdy anodised base, which can be permanently fixed to a workstation, ensures stability during testing.



### Technical Specification

**C,A** certificate available

Part Number	Description
<b>K0001510M001</b>	Elcometer 1510 Conical Mandrel Bend Tester
Diameter Range	3.2 - 38.1mm (0.1 x 1.5")
Sample Size	180 x 100 x 0.8mm (7 x 4 x 0.03")
Dimensions	325 x 350 x 100mm (12.8 x 13.8 x 4")
Weight	9kg (20lb)
Packing List	Elcometer 1510 Conical Mandrel Bend Tester and operating instructions

*Can be used in accordance with: (see Standards Explained inside Front Cover)*  
**ASTM D 522-4, BS 3900-E11, ISO 6860**

Customers who purchased the Elcometer 1510 also purchased:



◀ Elcometer 1542 Cross Hatch Adhesion Cutter, page 218

Elcometer 456 Digital Coating Thickness Gauge, page 188 - 199



## Elcometer 1506 Cylindrical Mandrel Bend Tester

Similar in use to the Elcometer 1510, the Elcometer 1506 is also a very robust mechanical unit for determining the elasticity, adhesion and elongation properties of cured coatings on sheet metal.

The frame has a bending lever with height-adjustable rollers and a sliding vice for clamping the sample which means the test pieces are bent perfectly and regularly on decreasing mandrels until the desired effect can be observed.

The instrument can be adjusted to the diameter of the mandrel used and the mandrels are easily changed.

The maximum width of the test piece is 70mm (2.75")

The maximum length of the test piece is 80mm (3.15") when using a 2mm (0.08") mandrel or 100mm (3.93") when using a 32mm (1.25") mandrel.

Each instrument is supplied with a kit of 14 stainless steel mandrels.



### Technical Specification

**C,A** certificate available

Part Number	Description
<b>K0001506M001</b>	Elcometer 1506 Cylindrical Mandrel Bend Tester ASTM-ISO Metric Version
<b>K0US1506M001</b>	Elcometer 1506 Cylindrical Mandrel Bend Tester ASTM Imperial Version
Mandrel Size	Metric Version: 2, 3, 4, 5, 6, 8, 10, 12, 13, 16, 19, 20, 25, and 32mm Imperial Version: 0.08, 0.12, 0.16, 0.20, 0.24, 0.31, 0.39, 0.47, 0.51, 0.63, 0.75, 0.79, 0.98, 1.25"
Test Piece Width	Maximum: 70mm (2.75")
Test Piece Length	Maximum: 80mm (3.15") using a 2mm (0.08") or 100mm (3.93") using a 32mm (1.25") mandrel
Dimensions	320 x 135 x 130mm (12.6 x 5.3 x 5.1")
Weight	4kg (9lb)
Packing List	Elcometer 1506 Cylindrical Mandrel Bend Tester, set of 14 mandrels and operating instructions
<i>Can be used in accordance with: (see Standards Explained inside Front Cover)</i>	
<b>AS/NZS 1580.402.1, ASTM D 522-B, ASTM D 1737, BS 3900 E1, DIN 53152, ISO 1519-2, NFT 30-040</b>	

### Accessories

<b>KT001506P201</b>	Elcometer 1506 Spare Set of 14 Metric Mandrels
<b>KTUS1506P201</b>	Elcometer 1506 Spare Set of 14 Imperial Mandrels

## Elcometer 1500 Cylindrical Mandrel on a Stand

The Elcometer 1500 is a simple instrument for determining the elasticity, adhesion and cracking of dry paint on flat specimens, consisting of a mandrel support which also serves as a test stand.

Coated metal sheets, maximum 150mm (5.9") in length x 100mm (3.93") wide, are manually and successively bent around mandrels of decreasing diameter until cracks appear.



### Technical Specification

**C,A** certificate available

Part Number	Description
<b>K0001500M002</b>	Elcometer 1500/2 Metric Set of 13 Cylindrical Mandrels on a stand from 2 to 32mm
<b>K0US1500M001</b>	Elcometer 1500/1 Imperial Set of 7 Mandrels from 1/8" to 1"
Mandrel Size	Metric Version: 2, 3, 4, 5, 6, 8, 10, 12, 13, 16, 20, 25, and 32mm Imperial Version: 3/4, 5/8, 1/2, 3/8, 1/4, 1/8"
Dimensions	178 x 138 x 145mm (7 x 5.3 x 5.7")
Weight	3.3kg (7.26lb)
Packing List	Set of 7 mandrels (Elcometer 1500/1), Set of 13 mandrels (Elcometer 1500/2) and operating instructions

Can be used in accordance with: (see Standards Explained inside Front Cover)

**AS/NZS 1580.402.1, ASTM D 522-B, ASTM D 1737, BS 3900-E1, NF T30-040, ISO 1519-2**



## Elcometer 1620 Cupping Tester

These robust and user-friendly instruments are used for assessing the cupping ability of coatings applied to metal sheets up to 1.2mm (0.05") thick.

The Elcometer 1620 has a 27mm (1.06") diameter hardened steel die in a clamping device and a 20mm (0.79") diameter punch. A hand-rotated crank and reduction drive moves the punch progressively into the sample.

The motorised version provides high levels of repeatability and replaces the manual crank handle to ensure perfect reproducibility. A constant "cupping speed" of 200µm per second (7.9mils per second) ensures an extremely high level of repeatability.

The Elcometer 1620 is available as either an analogue or a digital gauge and both models are supplied with an illuminated magnifier to accurately view the resultant damage and provides accurate readings of the cupping depth on an integrated gauge. Direct viewing of the fissures, cracks and tears in the coating of up to 10µm (0.4mil) can be viewed through the supplied x10 illuminated magnifying glass.



### Technical Specification

 certificate available

Part Number	Description	Gauge Type
K0001620M002	Elcometer 1620/2 Manual Cupping Tester	Analogue (mm, mils)
K0001620M004	Elcometer 1620/4 Manual Cupping Tester	Digital (mm, mils)
K0001620M003	Elcometer 1620/3 Motorised Cupping Tester (UK/EUR 230V)	Analogue (mm)
K0US1620M003	Elcometer 1620/3 Motorised Cupping Tester (US 110V)	Analogue (mils)
K0001620M005	Elcometer 1620/5 Motorised Cupping Tester (UK/EUR 230V)	Digital (mm, mils)
K0US1620M005	Elcometer 1620/5 Motorised Cupping Tester (US 110V)	Digital (mm, mils)
Dimensions	Manual: 300 x 240 x 500mm (12 x 10 x 20") Motorised: 410 x 240 x 500mm (16 x 10 x 20")	
Weight	Manual: 24kg (531lb) Motorised: 30kg (66lb)	
Packing List	Elcometer 1620 Cupping Tester, gauge, gauge holder, zero setting sheet, illuminated 10x magnifying glass with magnet, mains cable (motorised versions only) and operating instructions	

Can be used in accordance with: (see Standards Explained inside Front Cover)

BS 3900 E4, DIN 53156, DIN 53232, ECCA T6, EN 13523-6, ISO 1520, NBN T22-104, NFT 30-019

### Accessories

KT001620P004	Illuminated Magnifying Glass (x10)
--------------	------------------------------------

## Elcometer 1615 Variable Impact Tester

This simple to use gauge is ideal for evaluating the resistance of a coating to impact (elongation, cracking or peeling).

There are two test methods: either a weight with a hemispherical punch attached falls on a coated metal sheet or a weight falls on to a hemispherical punch which is resting on the coated metal sheet.

The Elcometer 1615 Impact Tester comes as one universal assembly with the option of six different kits providing the functionality for various testing methods.

The test specimen is fixed into position by the quick release clamp. The weight is lifted to the predetermined height and can be set by the adjustable collar device. The weight is then released and the resulting deformation is observed.

The base unit is common to all tests. Simply select the appropriate kit to meet your requirements.

- Heavy-duty, passivated base plate and anodised arm for long life
- Graduated tube with engraved markings
- Quick, safe weight release mechanism
- Integrated bubble level to ensure the tester is perpendicular for accurate results
- Stop collar with 10 settings between 2mm and 15mm (0.08 and 0.60") to change the depth of impact when working in accordance with ISO Standards, supplied with Kits A, D and F
- Easy fix sample clamp - the test sample can be secured or released by a simple twist of the clamp handle supplied with Kits A, D and F
- Magnifier x10

*Please see page 104 - 105 for the list of available kits and page 106 for the full range of accessories.*

---

*Can be used in accordance with: (see Standards Explained inside Front Cover)*

ASTM D 2794:2004, ASTM D 5420 AS/NZS 1580.406, BS 6496:1984,  
BS 3900 E13, ECCA T5, EN 12206-1:2004, EN 13523-5:2001, ISO 6272:1993,  
ISO 6272-1:2002, ISO 6272-2:2002, JIS K 5600-5-3:1999, NFT 30-017:1989

---



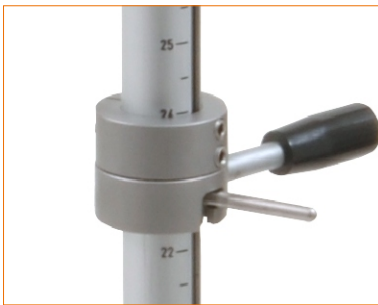

The tube has clearly engraved, graduated markings in both kg-cm and lb-inch to ensure accuracy and a quick, safe weight release mechanism which holds the weight safely and allows a smooth release.

Tube height: 1000mm (39")



The stop collar, supplied with Kits A, D and F or as an optional accessory, allows the penetration depth to be limited. By rotating the stop collar, the user can select the depth required between 2 - 15mm (0.08 - 0.60").

Values: 2, 3, 4, 5, 6, 7, 8, 9, 10 and 15mm  
(0.08, 0.12, 0.16, 0.20, 0.24, 0.28, 0.31, 0.35, 0.39 and 0.60")

Each Impact Tester is supplied with an integrated bubble level ensuring accurate setup prior to any test.



The Elcometer 1615 Variable Impact Testers are designed to meet a wide range of national and international Standards. Simply select the appropriate kit from pages 104 - 105 and attach the punch, die and accessories to the base unit. Interchangeable die - enables the user to match the die to the size of the relevant punch to conform to the required Standard or method.

The optional easy to fix sample clamp enables the user to quickly and safely secure the sample.

Technical Specification



Part Number	Description
<b>K0001615M201</b>	Elcometer 1615 Impact Tester Universal Base Unit and Tube
Weight	10.6kg (23.4lb)
Dimensions	1460 x 200 x 165mm (57.5 x 8.0 x 6.5")
Packing List	Elcometer 1615 Impact Tester with passivated base, integrated bubble leveller, graduated tube, collar release mechanism and operating instructions

For the full range of Kits and Accessories, please see pages 104 - 106

In order to test a sample in accordance with a specified standard, a number of kits has been created to provide a single Impact Tester which, by using the appropriate kit, the user can work in accordance with a wide range of national and international standards. (See *Standards Explained inside Front Cover*)

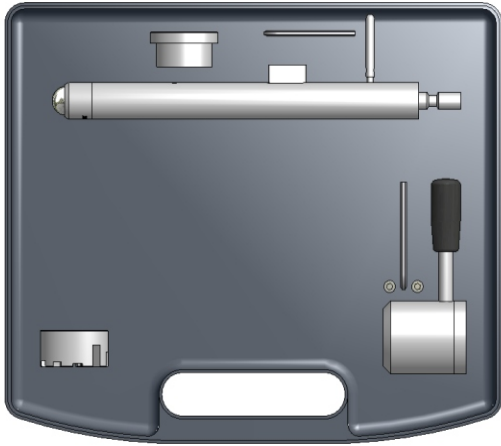

### Kit A

Part Number: **KT001615KITA**

Can be used in accordance with:

**ISO 6272:1993, BS 3900-E13**

- Falling 1kg (2.2lb) weight with a 20mm (0.7") punch
- Stop collar
- 27mm (1.06") die with fixing screw
- Sample clamp with two fixing screws
- 3mm (0.12") and 4mm (0.15") hexagonal wrench

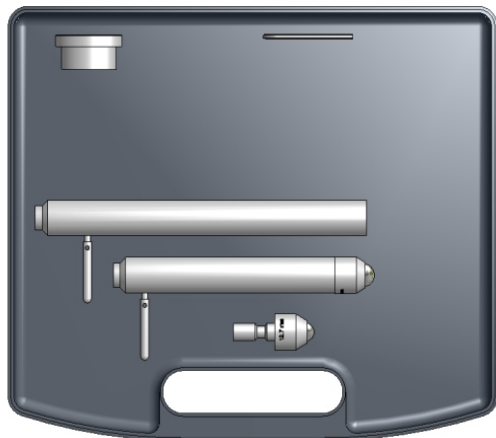

### Kit B

Part Number: **KT001615KITB**

Can be used in accordance with:

**ISO 6272 Part 2:2002**

- Static indenter with 15.9mm (0.6") punch
- Falling 1kg (2.2lb) weight
- 12.7mm (0.5") punch
- 16.3mm (0.64") die with fixing screw
- 3mm (0.12") hexagonal wrench

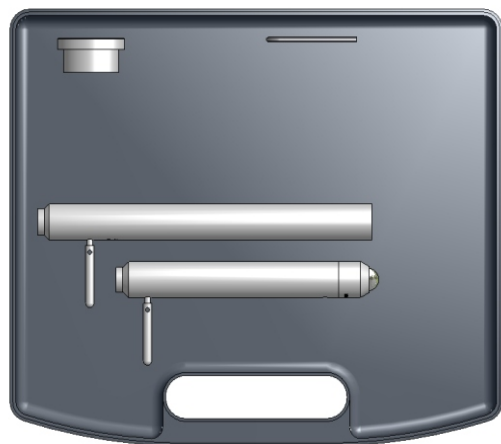

### Kit C

Part Number: **KT001615KITC**

Can be used in accordance with:

**ASTM D2794 Method 2, BS6496:1984, EN 12206-1**

- Static indenter with 15.9mm (0.6") punch
- Falling 2lb (908g) weight
- 16.3mm (0.64") die with fixing screw
- 3mm (0.12") hexagonal wrench

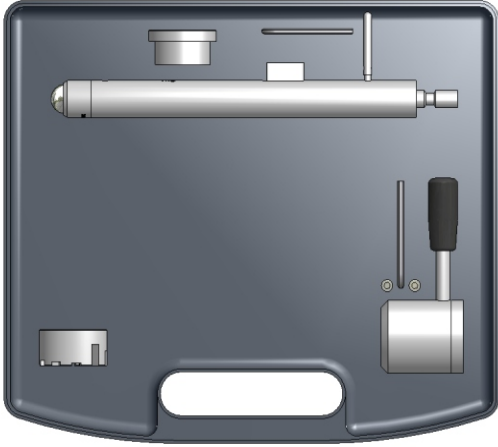

**Kit D**

Part Number: **KT001615KITD**

Can be used in accordance with:

**ISO 6272 Part 1:2002, BS EN ISO 6272-1:2004**

- Falling 1kg (2.2lb) weight with 20mm (0.78") punch and stop key
- 27mm (1.06") die with fixing screw
- Stop collar
- Sample clamp with fixing screws,
- 3mm (0.12") and 4mm (0.15") hexagonal wrench



**Kit E**

Part Number: **KT001615KITE**

Can be used in accordance with:

**NF T30-017:1989**

- Falling 400g (0.9lb) weight with 23mm (0.90") punch
- 22mm (0.87") die with fixing screw
- 3mm (0.12") hexagonal wrench

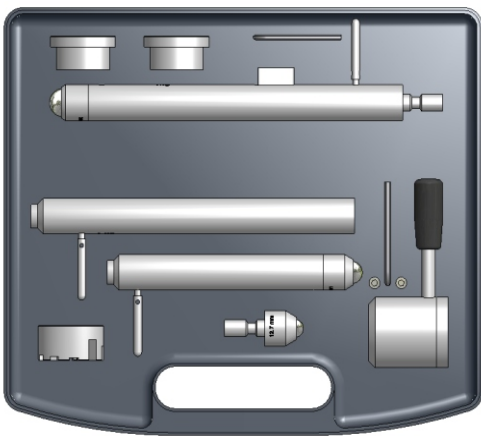

**Kit F**

Part Number: **KT001615KITF**

Can be used in accordance with:

**ISO 6272:1993, ISO 6272- 2:2002**

- Falling 1kg (2.2lb) weight with a 20mm (0.7") punch
- Stop collar
- 27mm (1.06") die with fixing screw
- Sample clamp with two fixing screws
- 3mm (0.12") and 4mm (0.15") hexagonal wrench
- Static indenter with 15.9mm (0.6") punch
- Falling 1kg (2.2lb) weight
- 12.7mm (0.5") punch
- 16.3mm (0.64") die with fixing screw

## Technical Specification



Part Number	Description
<b>K0001615M201</b>	Elcometer 1615 Universal base unit & tube assembly
Instrument Weight	10.6kg (23.34lb)
Dimensions	1460 x 200 x 165mm (57.5 x 8.0 x 6.5")
Packing List	Elcometer 1615 Impact Tester with passivated base, integrated bubble leveller, graduated tube, collar release mechanism and operating instructions
<b>KT001615KITA</b>	Elcometer 1615 Kit A to meet ISO 6272:1993 Standard
<b>KT001615KITB</b>	Elcometer 1615 Kit B to meet ISO 6272 Part 2:2002 Standard
<b>KT001615KITC</b>	Elcometer 1615 Kit C to meet ASTM D2794 Method 2, BS6496:1984, EN 12206-1 Standards
<b>KT001615KITD</b>	Elcometer 1615 Kit D to meet ISO 6272 Part 1:2002, BS EN ISO 6272-1:2004 Standards
<b>KT001615KITE</b>	Elcometer 1615 Kit E to meet NF T30-017:1989 Standard
<b>KT001615KITF</b>	Elcometer 1615 Kit F to meet ISO 6272:1993, ISO 6272- 2:2002 Standards
Packing List	Kit A: Sample clamp, 27mm (1.06") die, 1kg (2.2lb) falling weight with a 20mm (0.79"), punch, stop collar, 2 x hexagonal wrench and operating instructions
	Kit B: Indenter with 15.9mm (0.6") punch, die 16.3mm (0.64"), falling 1kg (2.2lb) weight, hexagonal wrench and operating instructions
	Kit C: Indenter with 15.9mm (0.6") punch, 2lb (0.91kg) falling weight and operating instructions
	Kit D: 1kg (2.2lb) falling weight with 20mm (0.79") punch, 27mm (1.06") die, stop collar, hexagonal wrench and operating instructions
	Kit E: 400g (0.88lb) falling weight with a 23mm (0.9") punch, 22mm (0.87") die, sample clamp, hexagonal wrench and operating instructions
	Kit F: Sample clamp, stop collar, 27mm (1.06") die, 1kg falling indenter with a 20mm (0.79") punch, indenter with 15.9mm (0.6") punch, 12.7mm (0.5") punch, 16.3mm (0.6") die, falling 1kg weight, 2 x hexagonal wrench and operating instructions

Can be used in accordance with: (see Standards Explained inside Front Cover)

ASTM D 2794:2004, ASTM D 5420, AS/NZS 1580.406.1, BS 6496:1984, BS 3900 E13, ECCA T5, EN 12206-1:2004, EN 13523-5:2001, ISO 6272:1993, ISO 6272-1:2002, ISO 6272-2:2002, JIS K 5600-5-3:1999, NF T30-017:1989

## Accessories

<b>KT001615N201</b>	Additional 1kg (2.2lb) Falling Weight, 24.6mm (0.97") Diameter
<b>KT001615N221</b>	Additional 1kg (2.2lb) Falling Weight, 25.0mm (0.98") Diameter
<b>KT001615N215</b>	12.7mm (0.5") Diameter Punch*
<b>KT001615N205</b>	15.9mm (0.6") Diameter Punch*
<b>KT001615N206</b>	20mm (0.79") Diameter Punch*
<b>KT001615N207</b>	23mm (0.9") Diameter Punch*
<b>KT001615N208</b>	Stop Ring Collar
<b>KT001615N209</b>	Sample Clamp Mechanism
<b>KT001615N210</b>	Weight Release Mechanism
<b>KT001615N211</b>	Replacement Graduated Tube
<b>KT001615N212</b>	16.3mm (0.64") Die
<b>KT001615N213</b>	22mm (0.67") Die
<b>KT001615N214</b>	27mm (1.06") Die

\* Punches are universal and can be used either fitted to a falling weight or as a punch resting on the sample

## Appearance

Visual appearance can determine a person's perception of a product. Colour and Gloss are two key parameters that are used to define a product's overall quality. Perception is subjective, but Elcometer's range of instruments quantify the appearance criteria.

### ▪ **Gloss:**

The ability of a surface to reflect light without scattering is known as gloss. Gloss is measured by directing a constant intensity light beam at a fixed angle to the test surface and then by monitoring the amount of reflected light at the same angle. Different surfaces require different reflective angles. Elcometer Glossmeters cover the range necessary to measure almost any surface from high gloss to matt, from large to small surfaces, flat or curved.

### ▪ **Haze:**

Some materials appear to have a considerable difference in gloss yet give comparable readings when measured with a traditional glossmeter. These materials can be differentiated by measuring at a second angle and comparing the two readings using a haze meter. Reflectance haze is defined by ASTM D4039 as the difference between gloss at 60° and the gloss at 20°.

### ▪ **Shade:**

The measurement of darkness or lightness of a surface, shading is measured irrespective of colour and is referred to as "whiteness". The test surface is illuminated at an angle of 45° and the intensity of scattered light at 0° is measured on a grey scale, where black is 0% and white is 100%.

### ▪ **Opacity:**

The degree to which a coating hides the surface to which it has been applied is known as opacity. Measured in a similar way to shade, opacity, (or hiding power), as defined by ISO 2814, involves measuring whiteness of a known film of test material on both a black (less than 5%) and a white (greater than 75%, less than 85%) substrate.

### ▪ **Colour:**

A material's ability to absorb certain wavelengths of light and reflect others is defined as its colour. For example a black material reflects no light across the complete colour spectrum. A pure white material reflects all of the light, whilst all other colours reflect light at different points of the spectrum. Colour is quantified by the material's Red, Green and Blue (RGB) values.



## Elcometer 406L Statistical Mini Glossmeter

Gloss is measured by directing a constant intensity light beam at an angle to the test surface and monitoring the reflected light at the same angle. Different gloss levels require different angles.

Elcometer Statistical Glossmeters cover the range necessary to measure any surface from high gloss to matt, providing a quantitative value to gloss measurement.

The low cost Elcometer 406L Statistical Mini Glossmeter is available in 60° and Dual Angle 20°/60° and is supplied with Novo-Soft™ software, see page 110.

- Single (60°) and Dual angle (20°/60°) readings
- Gloss readings from matt (non-reflective surfaces) to mirror finish
- Continuous measurements for variable surfaces
- 200 reading memory
- Unique calibration tile condition warning
- Quick, automatic calibration
- Menu driven operation in multiple languages
- LED light source is long lasting and stable
- Full traceability to National Standards, including BAM



### Technical Specification

certificate available

Part Number	Description
J406L--60S	Elcometer 406L 60° Statistical Mini Glossmeter
J406L--2060S	Elcometer 406L Dual 20°/60° Statistical Mini Glossmeter
Accuracy	Reproducibility ±0.5 Gloss Units (GU)
Measurement Resolution	0.1GU
Dimensions	125 x 50 x 100mm (4.9 x 2.0 x 3.9")
Weight	350g (12.3oz)
Power Supply	5 x LR03 (AAA)
Measurement Range	0 - 1,000 GU for 60° 0 - 2,000 GU for 20°
Memory	200 readings per angle
Packing List	Elcometer 406L Statistical Mini Glossmeter, 5 x LR03 (AAA) alkaline batteries, screwdriver, certified calibration tile, cleaning cloth for tile, calibration certificate for tile, CD-ROM containing Novo-Soft™ software package, USB cable, carry case and operating instructions

Can be used in accordance with: (see Standards Explained inside Front Cover)

AS/NZS 1580.602.2, ASTM C 584, ASTM D 1455, ASTM D 2457, ASTM D 523, ECCA T2, EN 12373-11, EN 13523-2, ISO 2813, ISO 766, TAPPI T 653, JIS Z 8741

### Accessories

T99918533	60° Gloss Standard Calibration Tile with Calibration Certificate
T99918534	20°/60° Gloss Standard Calibration Tile with Calibration Certificate
T99920213	USB Cable



## Elcometer 407 Triple Angle Statistical Glossmeter

The Elcometer 407 Statistical Glossmeter measures gloss at three angles of reflection; 20°, 60° and 85° and uses the internal memory to store readings.

Gloss is measured by directing a constant intensity light beam at an angle to the test surface and monitoring the reflected light at the same angle. Different gloss levels require different angles.

Gloss measurement is necessary to monitor the uniformity, compatibility, or possibly the deterioration of any protective gloss finish.

The Elcometer 407 Statistical Glossmeter is supplied with Novo-Soft™ software, see page 110.

- Gloss readings from matt (non-reflective surfaces) to mirror finish
- Continuous measurements for variable surfaces
- 200 reading memory
- Unique calibration tile condition warning
- Quick, automatic calibration
- Menu driven operation in multiple languages
- LED light source is long lasting and stable
- Full traceability to National Standards, including BAM



### Technical Specification

 certificate available

Part Number	Description
J407----1	Elcometer 407 Statistical Glossmeter (20,60 85°)
Accuracy	Reproducibility ±0.5 Gloss Units (GU)
Measurement Resolution	0.1GU
Dimensions	190 x 110 x 60mm (7.5 x 4.3 x 2.3")
Weight	950g (33oz)
Power Supply	4 x LR6 (AA)
Memory	200 readings per angle
Measurement Range	60° Glossmeter: 0 - 1000 GU 20° Glossmeter: 0 - 2000 GU 85° Glossmeter: 0 - 200 GU
Packing List	Elcometer 407 Statistical Glossmeter, 4 x LR6 (AA) alkaline batteries, screwdriver, certified calibration tile in magnetic holder, calibration certificate for tile, cleaning cloth for tile, CD-ROM containing Novo-Soft™ software package, USB cable, carry case and operating instructions

Can be used in accordance with: (see Standards Explained inside Front Cover)

AS/NZS 1580.602.2, ASTM C 584, ASTM D 1455, ASTM D 2457, ASTM D 523, ECCA T2, EN 12373-11, EN 13523-2, ISO 2813, ISO 766, TAPPI T 653, JIS Z 8741

### Accessories

T40720091	High Gloss Standard Tile
T40720105	Zero Calibration Standard
T40720093	USB Cable

## Elcometer Novo-Soft™ Software

This easy to use software provides users with a means to download readings from all Elcometer gloss, haze and opacity meters for data storage, analysis and reporting.

Supplied free of charge with the Elcometer 400, 406L, 407, 6012 and 6014 gauges, Elcometer Novo-Soft™ allows users to:

- Save readings for your internal records
- Add notes against individual readings
- Graphically analyse your measurement data
- Exclude erroneous readings from your statistical analysis
- Compare individual batches of data, graphically
- Compare results from different angles of geometry
- Combine separate batches for group statistical analysis
- Export data in different file formats (.xls, .csv, etc)
- Change user preferences including language, calibration options, etc. on the Elcometer 406L and Elcometer 6014 gauges



## Choosing the angle for Gloss Measurement

All light sources reflect from a surface, the degree of the amount of light reflected is known as the surface gloss value. Gloss value is measured in Gloss Units (GU) relative to a Standard of approx. 100 GU. Gloss can be categorised into 3 general ranges, low, semi and high.

Each of these are best measured at their own unique respective angles. To determine the most appropriate angle at which to measure, starting at 60° gives a good indication. If the result lies within 10 - 70 GU, the coating is termed semi-gloss and is best measurable at this angle. If the result is less than 10GU, the product is low gloss and should be measured at 85° and finally, if the result lies above 70GU, the product is high gloss and is best measured at 20°.

All angles are taken from the perpendicular, as shown below.

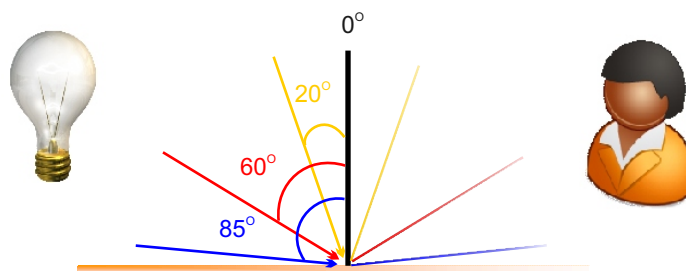

## Elcometer 400 Novo-Curve™ Glossmeter for Curved Surfaces

Developed in collaboration with the UK's National Physical Laboratory (NPL), the Elcometer 400 glossmeter's small measurement area and unique sample positioning system ensures that components can be accurately positioned, making this glossmeter the ideal unit for taking measurements on small, curved or complex surfaces.

The Elcometer 400 glossmeter's 8mm<sup>2</sup> (0.01sq inch) measurement area is approximately 3% of the area usually required by standard glossmeters.

### Features:

- Continuous reading mode, allowing rapid assessment of the variation of the surface gloss
- Statistical analysis at the touch of a button
- Internal Memory - up to 199 readings can be stored in the gauge
- USB Data Output to PC - instant reports using Elcometer's Novosoft™ Software
- Auto ranging geometry - readings can be taken over the entire gloss range, from matt to mirror finish
- Remote data capture trigger



### Technical Specification

 certificate available

Part Number	Description
J400----1	Elcometer 400 Novo-Curve™ Glossmeter
Geometry	60° with auto-ranging - for measurement over the entire Gloss Range - matt to mirror
Dimensions	260 x 220 x 100mm (10 x 8.5 x 4.5")
Memory	199 readings
Interface	USB
Power Supply	110-120V AC or 220-240V AC
Measurement Area	2 x 2mm (0.08 x 0.08")
Weight	2.5kg (5.5lb)
Packing List	Elcometer 400, black gloss (high gloss) and black foam (zero) calibration standards in wooden box, foot operated switch, four removable support posts, Novo-Soft™ software on CD, PC interface cable, UK, EUR & US power leads and operating instructions

### Accessories

T40019998	Cylinder Measurement Placement Jig
-----------	------------------------------------

## Elcometer 6012 Novo-Haze™ Haze Meter

Some materials appear to have considerable difference in gloss yet give comparable readings when measured with a glossmeter at one angle. These materials can be differentiated by measuring at a single point using two angles and comparing the readings.

Haze is defined by ASTM D 4039 as the difference between gloss at 60° and gloss at 20°. Measurements are made by placing the instrument on the test surface and pressing a button. Two consecutive gloss readings are automatically taken and the calculated haze value is displayed.

The Elcometer 6012 Novo-Haze™ can also be used as a 20° and 60° glossmeter.



### Technical Specification



UK 240V	EUR 220V	US 110V	Description
<b>KOUK6012M001</b>	<b>K0006012M001</b>	<b>K0US6012M001</b>	Elcometer 6012 Novo-Haze™ Haze Meter
Weight	0.9kg (1.98lb)		
Dimensions	150 x 50 x 100mm (6 x 2 x 4")		
Power Supply	Internal Rechargeable Battery		
Charger Supply	UK/EUR: 220 - 240V AC US: 110 - 120V AC		
Packing List	Elcometer 6012, calibration tile with calibration certificate, cleaning cloth, Novo-Soft™ software on CD, RS232 cable, screwdriver, carry case and operating instructions		

Can be used in accordance with: (see Standards Explained inside Front Cover)  
**ASTM D 4039, ISO 13803**

Customers who purchased the Elcometer 6012 also purchased:



◀ Elcometer 215 Oven Data Logger, page 168 - 172

Elcometer 456 Digital Coating Thickness Gauge, page 177 - 188 ▶



## Elcometer 6014 Shade & Opacity Meter

The Elcometer 6014 Shade & Opacity Meter is a low-cost dual function reflectometer for measuring shade and opacity using 45°/0° geometry.

This 2-in-1 gauge is the perfect choice for any industry that needs to measure the shade and opacity of its products.

### Features:

- Automatic calibration mode for accurate and fast calibration
- Accurately calculates opacity using up to six values over black and white for accurate readings
- Statistical analysis for up to 25 batches provides instant indication of batch quality
- Readings can be stored on the gauge and downloaded to a PC to utilise the supplied software
- Continuous read feature, ideal for quickly checking large surfaces
- Use in conjunction with opacity charts for repeatable testing



### Technical Specification

**C** certificate available

Part Number	Description
<b>K0006014M001</b>	Elcometer 6014 Shade & Opacity Meter
Measurement Units	Shade: 0% (black) to 100% (white) Opacity: 0% (transparent) to 100% (opaque) relative to 5% white & 75-85% black
Resolution	0.1%
Repeatability <sup>a</sup>	0.2%
Reproducibility <sup>b</sup>	0.5%
Display	Liquid Crystal Display (LCD) 3½ digits
Operating Temperature	0°C to 50°C (32°F to 120°F)
Weight	470g (16.5oz)
Measurement Area	15 x 10mm (0.59 x 0.39") ellipse
Battery Type	Dry batteries: 4 x LR6 (AA)
Battery Life	3000 readings
Packing List	Elcometer 6014 Shade & Opacity Meter, 4 x LR6 (AA) alkaline batteries, screwdriver, calibration tile with protective box and cleaning cloth, calibration certificate for tile, Novo-Soft™ software on CD, USB cable, carry case and operating instructions

Can be used in accordance with: (see Standards Explained inside Front Cover)

ASTM D 2745, ASTM D 2805, ASTM D 4039, AS/NZS 1580.213.2, DIN 53146, DIN 55984, ISO 2814, ISO 6504-3, BS 3900-D3

a. Repeatability is the variation given by a single instrument on an area of known gloss.

b. Reproducibility is the variation given by several instruments measuring an area of known gloss.

### Accessories

<b>KT006014P001</b>	Certified Calibration Standard
<b>T99920213</b>	USB Cable

## Elcometer 6014 Test Charts

### Technical Specification

certificate available

Part Number Box	Case	Description	Chart Dimensions		Box Weight	Quantity per Box	Boxes per Case
			mm	inches			
K0004695M003	K0004695M203	Leneta Chart 2A	140 x 254	5½ x 10	2.72kg (6lb)	250	6
K0004695M004	K0004695M204	Leneta Chart 2C	194 x 260	7½/8 x 10¼/4	4.08kg (9lb)	250	4
K0004695M006	K0004695M206	Leneta Chart 3B	194 x 289	7½/8 x 11¾/8	4.08kg (9lb)	250	4
K0004695M015	K0004695M215	Leneta Chart 5C	194 x 260	7½/8 x 10¼/4	4.08kg (9lb)	250	4
K0004695M036	K0004695M236	Leneta Chart 14H	286 x 438	11¼/4 x 17¼/4	5kg (11lb)	125	4
K0004695M037	K0004695M237	Leneta Chart 15H	286 x 438	11¼/4 x 17¼/4	5kg (11lb)	125	4



Chart 2A



Chart 2C



Chart 3B



Chart 5C



Chart 14H

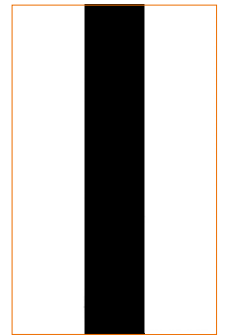

Chart 15H

Customers who purchased the Elcometer 6014 also purchased:



◀ Elcometer Film Applicators,  
page 40 - 48

Elcometer Test Charts, ▶  
page 55 - 64



## Elcometer 6210 RAL Colour Charts

A system of reference colours, enabling many industrial products to be identified, compared and classified, ideal for use with Elcometer 6300 Colour Assessment Cabinets, see pages 116 - 118.

Available either in the form of compact colour charts or in separate sheets of different sizes, with or without colourmetric identification, separately or in groups supplied in a file or a box.



Elcometer 6210 RAL Chart K1  
Part Number:  
K0006210M013



Elcometer 6210 RAL Chart 841-GL  
Part Number:  
K0006210M015  
Gloss finished RAL Classic colour A5



Elcometer 6210 RAL Chart K6  
Part Number:  
K0006210M014  
Folder with RAL Classic colour sheets.



Elcometer 6210 RAL Chart K7  
Part Number:  
K0006210M002  
Fan deck with RAL Classic colours,  
5 per sheet



Elcometer 6210 RAL Chart K5  
Part Number:  
K0006210M001  
Fan deck with RAL Classic colours.



Elcometer 6210 RAL Chart F3  
Part Number:  
K0006210M012  
Colour Chart, folded to A6



Elcometer 6210 RAL Chart F9  
Part Number:  
K0006210M006



Elcometer 6210 RAL Chart 840-HR  
Part Number:  
K0006210M009



Elcometer 6210 RAL Chart F1  
Part Number:  
K0006210M010  
Colour chart with removable colour clips



Elcometer 6210 RAL Chart F2  
Part Number:  
K0006210M011  
Colour chart with fixed colour chips

## Elcometer 6300 Colour Assessment Cabinets

Colour assessment cabinets are suitable for any industry where there is a need to maintain colour consistency and quality. These include paint, textiles, automotive, ceramics, cosmetics, dyeing, food, footwear, inks, knitwear, packaging, printing, etc.

The Elcometer 6300 range of colour assessment cabinets, also known as light cabinets or colour matching booths, ensures accurate visual colour assessment and colour comparison. Constructed from steel, Elcometer's lightweight colour assessment cabinets are supplied with different light sources used to simulate different conditions.

Light sources available:

- Artificial Daylight (D65)
- Point of Sale Illuminant (TL84 supplied with UK 240V/EUR 220V models, CWF supplied with US 110V models)
- Home Illuminant (Illuminant A)
- Ultraviolet Illuminant (UV)
- Alternative Point of Sale Illuminant (TL83 emits a reddish, yellow energy)

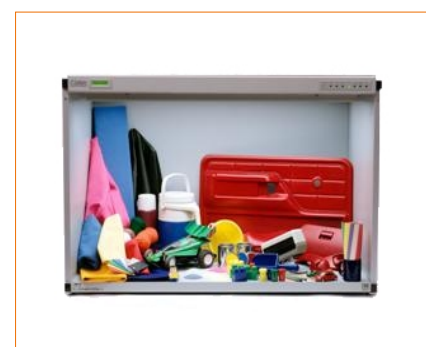

The Elcometer 6300 Colour Assessment Cabinets also enable easy detection of metamerism. Metamerism is commonly discussed in the terms of illuminants, where two samples appear the same (spectrally matched) under one illuminant, but not another. For example, two car door panels appear the same colour in daylight, but, under a streetlight at night, appear completely different colours.

There is a choice of 3, 4 or 5 light sources with the Elcometer 6300 range. Cabinets are either available with manual light source selection or digital light source selection. The digital cabinets are able to programme the sequence of lights and the duration of each illumination. The lamp timer function, which is standard on all digital cabinets and as an option on manual cabinets, measures the number of hours the D65 daylight bulb has been in operation.

### Colour Assessment Cabinet Overview

Model	Light Sources					Weight	Control
	D65	TL84/CWF	Illuminant A	UV	TL83		
Elcometer 6300 MM-1E	▪	▪	▪			14kg (30lb)	Manual
Elcometer 6300 MM-2E	▪	▪	▪			10kg (22lb)	Manual
Elcometer 6300 MM-4E	▪	▪	▪	▪	▪	17kg (38lb)	Digital
Elcometer 6300 MM-1E UV/65	▪	▪	▪	▪		14kg (30lb)	Manual
Elcometer 6300 MM-2E UV/65	▪	▪	▪	▪		10kg (22lb)	Manual
Elcometer 6300 CMB-2028	▪	▪	▪	▪	▪	32kg (70lb)	Digital
Elcometer 6300 CMB-2540	▪	▪	▪	▪	▪	44kg (97lb)	Digital
Elcometer 6300 CMB-3052	▪	▪	▪	▪	▪	70kg (155lb)	Digital



The Elcometer 6300 range is available with a choice of 3, 4 or 5 light source cabinets, in a range of sizes and functionality to suit your particular requirements. Lamp Kits are available for each Colour Assessment Cabinet.

## Colour Assessment Cabinet Dimensions

Part Number			Model	Dimensions	Light Sources
UK 240V	EUR 220V	US 110V			
<a href="#">K0UK6300M002</a>	<a href="#">K0006300M002</a>	<a href="#">K0US6300M002</a>	Elcometer 6300 MM-1E	483 x 660 x 432mm (19 x 26 x 17")	3
<a href="#">K0UK6300M001</a>	<a href="#">K0006300M001</a>	<a href="#">K0US6300M001</a>	Elcometer 6300 MM-2E	457 x 580 x 330mm (18 x 20 x 13")	3
<a href="#">K0UK6300M003</a>	<a href="#">K0006300M003</a>	<a href="#">K0US6300M003</a>	Elcometer 6300 MM-4E	483 x 685 x 483mm (19 x 27 x 19")	5
<a href="#">K0UK6300M202</a>	<a href="#">K0006300M202</a>	<a href="#">K0US6300M202</a>	Elcometer 6300 MM-1E UV/65	483 x 660 x 432mm (19 x 26 x 17")	4
<a href="#">K0UK6300M201</a>	<a href="#">K0006300M201</a>	<a href="#">K0US6300M201</a>	Elcometer 6300 MM-2E UV/65	457 x 580 x 330mm (18 x 20 x 13")	4
<a href="#">K0UK6300M004</a>	<a href="#">K0006300M004</a>	<a href="#">K0US6300M004</a>	Elcometer 6300 CMB-2028	635 x 762 x 559mm (25 x 30 x 22")	5
<a href="#">K0UK6300M005</a>	<a href="#">K0006300M005</a>	<a href="#">K0US6300M005</a>	Elcometer 6300 CMB-2540	787 x 1067 x 686mm (31 x 42 x 27")	5
<a href="#">K0UK6300M006</a>	<a href="#">K0006300M006</a>	<a href="#">K0US6300M006</a>	Elcometer 6300 CMB-3052	914 x 1372 x 787mm (36 x 54 x 31")	5

Packing List Elcometer 6300 Light source, viewing surface, side walls, rear wall, power cable, assembly instructions, maintenance and operating instructions.

Can be used in accordance with: (see Standards Explained inside Front Cover)  
[AS/NZS 1580.601.1](#), [ASTM D1729](#), [BS-950-2](#), [ISO 3668](#), [SAE J361](#), [TAPPI T515](#)

## Accessories

Part Number			Description
UK 240V	EUR 220V	US 110V	
<a href="#">KTUK6300P002</a>	<a href="#">KT006300P002</a>	<a href="#">KTUS6300P002</a> *	Elcometer 6300 MM-1E Lamp Kit D65, TL84 & Illuminant A
<a href="#">KTUK6300P001</a>	<a href="#">KT006300P001</a>	<a href="#">KTUS6300P001</a> *	Elcometer 6300 MM-2E Lamp Kit D65, TL84 & Illuminant A
<a href="#">KTUK6300P003</a>	<a href="#">KT006300P003</a>	<a href="#">KTUS6300P003</a> *	Elcometer 6300 MM-4E Lamp Kit D65, TL84, Illuminant A, UV & TL83
<a href="#">KTUK6300P202</a>	<a href="#">KT006300P202</a>	<a href="#">KTUS6300P202</a> *	Elcometer 6300 MM-1E UV/65 Lamp Kit D65, TL84, Illuminant A & UV
<a href="#">KTUK6300P201</a>	<a href="#">KT006300P201</a>	<a href="#">KTUS6300P201</a> *	Elcometer 6300 MM-2E UV/65 Lamp Kit D65, TL84, Illuminant A & UV
<a href="#">KTUK6300P004</a>	<a href="#">KT006300P004</a>	<a href="#">KTUS6300P004</a> *	Elcometer 6300 CMB-2028 Lamp Kit D65, TL84, Illuminant A, UV & TL83
<a href="#">KTUK6300P005</a>	<a href="#">KT006300P005</a>	<a href="#">KTUS6300P005</a> *	Elcometer 6300 CMB-2540 Lamp Kit D65, TL84, Illuminant A, UV & TL83
<a href="#">KTUK6300P006</a>	<a href="#">KT006300P006</a>	<a href="#">KTUS6300P006</a> *	Elcometer 6300 CMB-3052 Lamp Kit D65, TL84, Illuminant A, UV & TL83

\* KTUS part numbers supplied with CWF light source, not TL84

## Light Source Key

D65	Artificial Daylight
TL84	Point of Sale Illuminant (supplied with UK 240V & EUR 220V units)
CWF	Point of Sale Illuminant (supplied with US 110V units)
TL83	Alternative Point of Sale Illuminant
Illuminant A	Home Illuminant
UV	Ultraviolet Illuminant

## Elcometer 6075/1 SP60 Portable Sphere Spectrophotometer

The Elcometer 6075/1 SP60 is an affordable sphere spectrophotometer, designed to give fast, precise and accurate colour measurement information on materials ranging from paper and paint to plastics and textiles.

- Lightweight, compact, portable instrument
- Diffuse/8° sphere optical geometry
- Fixed 8mm aperture
- Large, easy-to-read graphical LCD display
- Opacity and colour strength measurement
- Simultaneous measurement of both specular component included and specular component excluded
- Rugged construction
- Rechargeable battery for remote use
- On-board inbuilt software PROJECTS: User can collect colours under one title. Data can be uploaded and/or downloaded via patented, bi-directional communication link to computer software.



---

### Key Features

- **Measuring Functions and Indices**

The Elcometer SP60 provides absolute and difference measurements for the following colourimetric systems. These values can be obtained from any of the nine illuminants with 2° or 10° observer angle: L\*a\*b\*, DL\*Da\*Db\*, L \*C\*h°, DL\*DC\*DH\*, DE\*ab, DECMC, DE CIE94 and XYZ. Whiteness and Yellowness per ASTM E 313-98.

- **Pass/Fail Mode**

The instrument stores up to 1024 standards with tolerances for easy pass/fail measurement. A red/green LED indicator and the LCD display provide visual confirmation of results. A tone also sounds to indicate a fail result and measurement completion.

- **Quick Colour Compare**

A quick measurement can be taken to compare two colours. This allows the operator to take quality control readings in a time efficient manner without having to create tolerances or store data.

- **The Sphere**

The Elcometer SP60's diffusing sphere is made of Spectalon®, a durable, highly reflective material designed to perform in a rigorous production environment. The diffusing material prevents degradation due to the flaking and chipping of the sphere wall material.

- **Opacity, Colour Strength and Shade Sorting**

The instrument can measure opacity as well as three colour-strength options: chromatic, apparent and tri-stimulus calculations. The Elcometer SP60 also performs 555 shade sorting. This is an important consideration in the colour quality control of manufactured products involving plastics, painted or textile materials.

- **Texture and Gloss influence**

To determine the influence of the specular component, the SP60 allows simultaneous measurement of both specular - included (colour) and specular-excluded (appearance)

- **User friendly Ergonomics**

In addition to on-board programmes to assist the operator in the measurement process, the instrument itself is highly user -friendly. It is compact and lightweight with a wrist strap and the tactile side grips make it easy to hold. Read-outs are large and easy to see. A rechargeable battery pack allows extended operation of the instrument.

Technical Specification



Part Number	Description		
UK 240V	EUR 220V	US 110V	
<b>K0UK6075M001</b>	<b>K0006075M001</b>	<b>K0US6075M001</b>	SP60 Portable Sphere Spectrophotometer 8mm Fixed Aperture
Measuring Geometrics	d/8°, DRS spectral engine, fixed aperture: 8mm viewing/12mm illumination		
Light Source	Gas filled tungsten lamp		
Illuminant Types	C, D50, D65, D75, A, F2, F7, F11, F12		
Standard Observers	2° and 10°		
Spectral Range	400-700nm		
Memory	1,024 standards with tolerances, 2,000 samples		
Measurement Range	0 to 200% reflectance		
Measuring Time	Approximately 2 seconds		
Inter-Instrument Agreement	<p><i>CIE L*a*b*</i>:</p> <p>Average 0.40 <math>\Delta E^*ab</math> based on average of 12 BCRA Series II tiles (specular component included)</p> <p>Maximum 0.60 <math>\Delta E^*ab</math> on any tile (specular component included)</p> <p><i>CMC Equivalent:</i></p> <p>Average 0.30 <math>\Delta E_{cmc}</math> based on average of 12 BCRA Series II tiles (specular component included)</p> <p>Maximum 0.50 <math>\Delta E_{cmc}</math> on any tile (specular component included)</p>		
Short-term Repeatability <sup>†</sup>	0.10 $\Delta E^*ab$ on white ceramic (standard deviation)		
Lamp Life	Approximately 500,000 measurements		
Power Supply	Removable (Ni-metal hydride) battery pack; 7.2 DC rated @1450mAh		
Measurements per Charge	1,000 measurements within 8 hour period		
Weight	1.1kg (2.4lb)		
Dimensions	109 x 83 x 195mm (4.3 x 3.3 x 7.7")		
Packing List	Elcometer 6075/1, calibration standards, AC adaptor, carry case & operating instructions		

<sup>†</sup>Based on 20 measurements on a white tile

Accessories

UK 240V	EUR 220V	US 110V	Description
<b>KTUK6075P001</b>	<b>KT006075P001</b>	<b>KTUS6075P001</b>	Battery Charger Kit
<b>KT006075P002</b>	<b>KT006075P002</b>	<b>KT006075P002</b>	NiMH Battery Pack

## Elcometer 6075/2 SP62 Portable Sphere Spectrophotometer

The Elcometer SP62 is an affordable sphere spectrophotometer, designed to give fast, precise and accurate colour measurement information on materials ranging from paper and paint to plastics and textiles.

- Lightweight, compact, portable instrument
- Diffuse/8° sphere optical geometry
- Choice of 4mm, 8mm or 14mm fixed aperture
- Large, easy-to-read graphical LCD display
- PROJECTS operation mode
- Flip-back target shoe for flexible use
- Simultaneous measurement of both specular component included and specular component excluded
- Rugged construction
- Rechargeable battery for remote use
- On-board inbuilt software:

PROJECTS - User can collect colours under one title. Data can be uploaded and/or downloaded via patented, bi-directional communication link to computer software.



### Key Features

#### ▪ Measuring Functions and Indices

The Elcometer SP62 provides absolute and difference measurements for the following colourmetric systems. These values can be obtained from any of the nine illuminants with 2° or 10° observer angle: CIE XYZ, CIE, Yxy, L\*a\*b\*, Hunter LAB, CIE L\*c\*h° (calculated from ab or uv space), CMC and CIE94. Whiteness and Yellowness in accordance with ASTM E313-98, Matamerism index and DIN 617.

#### ▪ Pass/Fail Mode

The Elcometer SP62 stores up to 1.024 standards with tolerances for easy pass/fail measurement. A red/green LED indicator and the LCD display provide visual confirmation of results. A tone also sounds to indicate a fail result and measurement completion.

#### ▪ Special PROJECTS Modes

Multiple colour standards can be collected under an identified PROJECT, a feature that supports corporate standards programmes.

#### ▪ Quick Colour Compare

An operator can take a quick measurement and compare two colours. This allows the operator to take quality control readings in a time efficient manner without having to create tolerances or store data.

#### ▪ The Sphere

The Elcometer SP62's diffusing sphere is made of Spectalon® a durable, highly reflective material designed to perform in a rigorous production environment. The diffusing material prevents degradation due to the flaking and chipping of the sphere wall material.

#### ▪ Opacity, Colour Strength and Shade Sorting

The instrument can measure opacity as well as three colour-strength options: chromatic, apparent and tri-stimulus calculations. The Elcometer SP62 also performs 555 shade sorting. This is an important consideration in the colour quality control of manufactured products involving plastics, painted or textile materials.

#### ▪ Texture and Gloss influence

To determine the influence of the specular component, the Elcometer SP62 allows simultaneous measurement of both specular-included (colour) and specular-excluded (appearance).

#### ▪ User friendly Ergonomics

In addition to on-board programs to assist the operator in the data collection process, the instrument itself is highly user - friendly. It is compact and lightweight with a wrist strap and the tactile side grips make it easy to hold. Read-outs are large and easy to see. A rechargeable battery pack allows extended operation of the instrument.

Technical Specification



Part Number		Description	
UK 240V	EUR 220V	US 110V	
K0UK6075M002	K0006075M002	K0US6075M002	SP62 Portable Sphere Spectrophotometer - 4mm Fixed Aperture
K0UK6075M202	K0006075M202	K0US6075M202	SP62 Portable Sphere Spectrophotometer - 8mm Fixed Aperture
K0UK6075M302	K0006075M302	K0US6075M302	SP62 Portable Sphere Spectrophotometer - 14mm Fixed Aperture
Measuring Geometrics	4mm Aperture	d/8°, DRS spectral engine, 4mm measurement area/6.5mm target window	
	8mm Aperture	d/8°, DRS spectral engine, 8mm measurement area/13mm target window	
	14mm Aperture	d/8°, DRS spectral engine, 14mm measurement area/20mm target window	
Light Source	Gas filled tungsten lamp		
Illuminant Types	C, D50, D65, D75, A, F2, F7, F11, F12		
Standard Observers	2° and 10°		
Spectral Range	400-700nm		
Memory	1,024 standards with tolerances, 2,000 samples		
Measurement Range	0 to 200% reflectance		
Measuring Time	Approximately 2 seconds		
Inter-Instrument Agreement	<p><i>CIE L*a*b*</i>:</p> <p>Average 0.20 <math>\Delta E^*ab</math> based on average of 12 BCRA Series II tiles (specular component included)</p> <p>Maximum 0.40 <math>\Delta E^*ab</math> on any tile (specular component included)</p> <p><i>CMC Equivalent:</i></p> <p>Average 0.15 <math>\Delta E_{cmc}</math> based on average of 12 BCRA Series II tiles (specular component included)</p> <p>Maximum 0.30 <math>\Delta E_{cmc}</math> on any tile (specular component included)</p>		
Short-term Repeatability†	0.05 $\Delta E^*ab$ on white ceramic (standard deviation)		
Lamp Life	Approximately 500,000 measurements		
Power Supply	Removable (Ni-metal hydride) battery pack; 7.2 DC rated @1450mAh		
Measurements per Charge	1,000 measurements within 8 hour period		
Temperature Range	10°- 40°C (50°- 104°F) 85% Relative Humidity Maximum (non-condensing)		
Data Interface	Patented bi-directional RS232, 300-57, 600 baud		
Weight	1.1kg (2.4lb)		
Dimensions	109 x 83 x 195mm (4.3 x 3.3 x 7.7")		
Packing List	Elcometer 6075/2, calibration standards, AC adaptor, carry case and operating instructions		

†Based on 20 measurements on a white tile

Accessories

Part Number		Description	
UK 240V	EUR 220V	US 110V	
KTUK6075P001	KT006075P001	KTUS6075P001	Battery Charger Kit
KT006075P002	KT006075P002	KT006075P002	NiMH Battery Pack

## Elcometer 6075/3 SP64 Portable Sphere Spectrophotometer

The SP64 is the ultimate sphere spectrophotometer, designed to give fast, precise and accurate colour measurement information on materials ranging from paper and paint to plastics and textiles.

- Lightweight, compact, portable instrument
- Large easy-to-read graphical LCD display
- Switchable 4mm or 8mm, or fixed 14mm aperture
- Opacity and colour strength measurement
- JOBS and PROJECTS operation mode
- Flip-back target shoe for flexible use
- Diffuse/8° sphere optical geometry
- 0.10ΔEcmc inter-instrument agreement
- Opacity and colour strength measurement
- Simultaneous measurement of both specular component included and specular component excluded
- Compatible with X-RiteColor® Master software, see page 124



---

### Key Features

#### ▪ Measuring Functions and Indices

The Elcometer SP64 provides absolute and difference measurements for the following colourimetric systems. These values can be obtained from any of the nine illuminants with 2° or 10° observer angle: CIE XYZ, CIE Yxy, CIE LAB, Hunter LAB, CIE LCH, CMC and CIE94. Whiteness and Yellowness in accordance with ASTM E313-98, Matamerism index and DIN 617.

#### ▪ Special JOB and PROJECTS Modes

The JOB function is a programmed sequence of specific steps to assist the operator in the colour measurement process. Up to six lines of specific instructions per measurement routine can be downloaded from X-Rite software and displayed on the SP64's LCD screen. Multiple colour standards can also be collected under an identified PROJECTS, a feature that supports corporate colour standards programmes.

#### ▪ Pass/Fail Mode

The Elcometer SP64 stores up to 1024 standards with tolerances for easy pass/fail measurement. A red/green LED indicator and the LCD display provide visual confirmation of results. A tone also sounds to indicate a fail result and measurement completion.

#### ▪ Switchable Apertures

The internal apertures can be quickly changed with the flip of a switch for 4mm or 8mm measurement areas. The instrument will recognise which aperture is being utilised and automatically adapt calibration data. This allows the operator to change the measurement mode quickly and efficiently, depending on the sample size.

#### ▪ The Sphere

The Elcometer SP64's diffusing sphere is made of Spectalon®, a durable, highly reflective material designed to perform in a rigorous production environment. The diffusing material prevents degradation due to the flaking and chipping of the sphere wall material.

#### ▪ Inter-Instrument Agreement

The instrument has superior inter-instrument agreement - essential in multiple instrument control programs. The SP64 offers excellent inter instrument agreement with X-Rite SP64 Sphere Spectrophotometer. Both input data into X-Rite line of Windows-based colour quality assurance and colour formulation software.

#### ▪ Opacity, Colour Strength and Shade Sorting

The instrument can measure opacity as well as three colour-strength options: chromatic, apparent and tri-stimulus calculations. The Elcometer SP64 also performs 555 shade sorting. This is an important consideration in the colour quality control of manufactured products involving plastics, painted or textile materials.

#### ▪ Texture and Gloss influence

To determine the influence of the specular component, the SP64 allows simultaneous measurement of both specular-included (colour) and specular-excluded (appearance).

## Technical Specification



Part Number			Description
UK 240V	EUR 220V	US 110V	
<b>KOUK6075M003</b>	<b>K0006075M003</b>	<b>KOUS6075M003</b>	SP64 Portable Sphere Spectrophotometer - 4 & 8mm Fixed Aperture
<b>KOUK6075M203</b>	<b>K0006075M203</b>	<b>KOUS6075M203</b>	SP64 Portable Sphere Spectrophotometer - 4 & 14mm Fixed Aperture
Measuring Geometrics	d/8°, DRS spectral engine, switchable 4mm measurement area/6.5mm target window or 8mm measurement area/13mm target window (optional fixed 14mm measurement area/20mm target window)		
Light Source	Gas filled tungsten lamp		
Illuminant Types	C, D50, D65, D75, A, F2, F7, F11, F12		
Standard Observers	2° and 10°		
Spectral Range	400-700nm		
Memory	1,024 standards with tolerances, 2,000 samples		
Inter-Instrument Agreement	<i>CIE L*a*b*</i> : Average 0.13 $\Delta E^*ab$ based on average of 12 BCRA Series II tiles (specular component included) Maximum 0.25 $\Delta E^*ab$ on any tile (specular component included) <i>CMC Equivalent</i> : Average 0.10 $\Delta E_{cmc}$ based on average of 12 BCRA Series II tiles (specular component included) Maximum 0.20 $\Delta E_{cmc}$ on any tile (specular component included)		
8mm/14mm			
4mm	<i>CIE L*a*b*</i> : Average 0.20 $\Delta E^*ab$ based on average of 12 BCRA Series II tiles (specular component included) Maximum 0.40 $\Delta E^*ab$ on any tile (specular component included) <i>CMC Equivalent</i> : Average 0.15 $\Delta E_{cmc}$ based on average of 12 BCRA Series II tiles (specular component included) Maximum 0.20 $\Delta E_{cmc}$ on any tile (specular component included)		
Short-term Repeatability <sup>†</sup>	0.05 $\Delta E^*ab$ on white ceramic (standard deviation)		
Measurement Range	0 to 200% reflectance		
Measuring Time	Approximately 2 seconds		
Lamp Life Approx	Approximately 500,000 measurements		
Power Supply	Removable (Ni-metal hydride) battery pack; 7.2 DC rated @1450mAh		
Measurements per Charge	1,000 measurements within 8 hour period		
Data Interface	Patented bi-directional RS232, 300-57,000 baud		
Weight	1.1kg (2.4lb)		
Dimensions	109 x 83 x 195mm (4.3 x 3.3 x 7.7")		
Packing List	Elcometer 6075/3, calibration standards, AC adaptor, carry case & operating		

## Accessories

Part Number			Description
UK 240V	EUR 220V	US 110V	
<b>KTUK6075P001</b>	<b>KT006075P001</b>	<b>KTUS6075P001</b>	Battery Charger Kit
<b>KT006075P002</b>	<b>KT006075P002</b>	<b>KT006075P002</b>	NiMH Battery Pack

## Elcometer 6090 X-RiteColor® Master Software

X-RiteColor® Master Software, has the power to measure, analyse, control and communicate colour data through one sophisticated, yet simple software programme. X-RiteColor® Master helps:

- Reduce cycle time
- Increase efficiency of colour data communication
- Minimise colour waste
- Create multiple formulation matches
- Get control of colour faster

X-RiteColor® Master is fully compatible with the X-Rite powerful line of 0/45, sphere, multi-angle and non-contact instruments.



### Technical Specification

	QA I	QA II	Formulation I	Formulation II	Formulation III
Part Number	K0006090M001	K0006090M002	K0006090M011	K0006090M012	K0006090M013
<b>Features</b>					
Colour-coded Tag Plot		■		■	■
Dot Area/Contrast Ratio Calculations		■		■	■
Multiple Formulation Methods		■	■	■	■
Quick Correct				■	■
Assign, create Tags and apply Filters		■		■	■
Multiple Tolerances for standards				■	■
User Defined Controls				■	■
Projects Jobs		■		■	■
Alternate Standard Creation		■		■	■
Display Options		■		■	■
View Sets		■		■	■
5 and 3 angle QA Database		■		■	■
Create/Modify Calibration Sets					■
ColourDesigner® Emulation					■
Vue-Rite® (on-screen colour)	■	■	■	■	■
General, Conformance, Custom & Sample Reports	■	■	■	■	■
<b>Multiple Illuminants</b>					
A, C, D50, D65, D75, F2, F7, F11, F12		■		■	■
<b>Data View</b>					
Multiple View Capability		■		■	■
Simple L*a*b* indices (L*a*b* data, general and textile), spectral data, status density, trend, notes and tags, and visual colour	■	■	■	■	■
Verbal Colour and FMC2		■		■	■
Formula		■	■	■	■
<b>Communications</b>					
Network (LAN) Version with ColorMail® (e-mail)	■	■	■	■	■
Server-Based (Internet) Computing					■



## Material Thickness

Ultrasonic thickness gauges are used to accurately determine the thickness of a variety of materials when only one side is accessible. Converting the time of flight of a pulse of sound energy, sent into and reflecting back from a defect or opposite surface, ultrasonic thickness gauges are ideal for not only measuring a material's thickness, but also detecting pits and flaws in a material without damage.

A coated surface may disguise defects in the substrate beneath; the wall thickness of a pipeline, for example, may have been eroded by the flow of the material inside. Likewise the walls of a storage tank may appear acceptable on the outside but be dangerously thin due to the corrosive chemicals stored within.

From a steel thickness gauge to a gauge which ignores the thickness of a the coating, Elcometer has a range of ultrasonic material thickness gauges to meet your specific requirements.

### Definitions:

#### ▪ **Scan Mode:**

Measuring up to 16 readings per second, the gauge captures the minimum recorded thickness

#### ▪ **Alarm Mode:**

Once a minimum acceptable thickness has been set, a red LED illuminates and a buzzer sounds if a measurement falls below the preset value

#### ▪ **Differential Mode:**

Set an acceptable thickness (nominal) value in the gauge and the unit will display the positive or negative ( $\pm$ ) difference from the nominal value entered

#### ▪ **Interface-to-Echo Mode:**

The standard method for measuring material thicknesses from 1.65mm to 25.4mm (0.065 to 1.00")

#### ▪ **Echo-to-Echo Mode:**

Measuring materials as thin as 0.15mm (0.006") the Echo-to-Echo mode ignores the thickness of any coating applied to the surface under inspection

#### ▪ **PLAS Mode:**

A mode specifically used for measuring very thin plastics. A special graphite delay line accessory is required for this mode



## Elcometer 207 Precision Ultrasonic Gauges

The Elcometer 207 series of Precision Ultrasonic Thickness Gauges is designed to provide accurate measurements on thin materials.

All Elcometer 207 and 207DL gauges also have the special PLAS mode. This is specifically designed to provide accurate readings when measuring thin plastics.

Using the latest transducer designs, the Elcometer 207 gauges can accurately measure material thickness from 0.15 - 254mm (0.006-1") without the need to change the measurement mode.



### Technical Specification

**C,A** certificate available

Part Number	C207----1	C207DL----1
Model	Elcometer 207	Elcometer 207DL
Interface-to-Echo Mode	■	■
Echo-to-Echo Mode	■	■
PLAS Mode*	■	■
High Speed Scan Mode	■	■
Differential Mode	■	■
Alarm Mode	■	■
Data Output (immediate)	■	■
Data Logging (Memory)		1000 readings
ElcoMaster™ Software		■
Maximum Measurement Range	0.15 - 25.4mm (0.006 - 1")	
Velocity Range	1250 - 10000m/s (0.0492 - 0.3937 in/μs)	
Accuracy	±0.002mm (0.0001")	
Resolution	0.002mm (0.0001")	
Units	Millimetres and Inches	
Operating Temperature	-30°C to 50°C (-20°F to 120°F)	
Transducer	Each unit is supplied with 15MHz, 6mm (¼") microdot right angle transducer	
Display	114mm (4½) Digit Liquid Crystal Display with backlight	
Power	AA 1.5V Alkaline or 1.2V NiCad cell	
Battery Life	200 hours Alkaline (120 hours NiCad)	
Weight	295g (10oz)	
Dimensions	63 x 120 x 31mm (2.5 x 4.5 x 1.24")	
Packing List	Elcometer 207 or 207DL gauge, ultrasonic couplant, 2 x batteries, carry case, microdot transducer and operating instructions. CD with ElcoMaster™ software and data transfer cable (Elcometer 207DL only)	

\* To use the PLAS mode, a special Graphite delay line is required which must be ordered separately - see Accessories

### Accessories

T92016871	Graphite Delay Line (for PLAS mode)
T92015701	Ultrasonic Couplant, 120ml (4fl oz) Bottle
T92015874	High Temperature Ultrasonic Couplant, 60ml (2fl oz) Bottle

## Elcometer 207 and 207DL Precision Ultrasonic Transducer

Elcometer Precision Ultrasonic Transducers are designed for thinner materials and have an accuracy to one one thousandth (0.001) of one millimetre (0.00004") and are suitable for a range of materials: Cast Iron, Steels, Plastic, Glass and Aluminium.

Standard Ultrasonic transducers are accurate to one, one hundredth (0.01) of one millimetre (0.0004").

The Ultrasonic transducer is available as a right-angled, microdot version only.

### Technical Specification

certificate available

Part Number	Measurement Range in Steel	Frequency MHz (Colour Code)	Crystal Diameter	Wearface Diameter
T92016526	0.15 - 25.4mm (0.006 - 1.0")	15.0 green	6.35mm (0.25")	7.42mm (0.3125")

## Speed of Sound Through Materials

Elcometer Ultrasonic Thickness Gauges can be calibrated by the user for the appropriate material in two ways:

- Set the calibration to the thickness of the known standard of the same material
- Set the frequency calibration to the appropriate value using the velocity chart below:

The Elcometer 204 is pre-calibrated for Steel only.

Material	km/sec	in/msec	Material	km/sec	in/msec
Air	0.33	0.013	Neoprene	1.60	0.063
Aluminium (2024-T4)	6.38	0.251	Nickel	5.64	0.222
Beryllium	12.88	0.507	Nylon	2.69	0.106
Boron Carbide	10.92	0.430	Platinum	3.69	0.156
Brass	4.39	0.173	Plexiglass	2.69	0.106
Cadmium	2.77	0.109	Polystyrene	2.34	0.092
Copper	4.65	0.183	Polyurethane	1.78	0.070
Glass (Plate)	5.77	0.227	PVC	2.39	0.094
Glycerine	1.93	0.076	Quartz	5.74	0.226
Gold	3.25	0.128	Silver	3.61	0.142
Inconel	5.82	0.229	Steel (4340)	5.84	0.230
Iron	5.89	0.232	Steel (303 Stainless)	5.66	0.223
Iron, Cast	4.55	0.179	Teflon	1.52	0.060
Lead	2.16	0.085	Tin	3.33	0.131
Magnesium	5.84	0.230	Titanium	6.10	0.240
Mercury	1.45	0.057	Tungsten	5.18	0.204
Molybdenum	6.25	0.246	Uranium	3.38	0.133
Monel	5.36	0.211	Water	1.47	0.058
Motor Oil (SAE 30)	1.75	0.069	Zinc	4.32	0.170

## Elcometer 204 Steel Ultrasonic Thickness Gauge

Pre-calibrated for ease of use, the Elcometer 204 Steel Ultrasonic Thickness Gauge provides a fast, accurate measurement of the thickness of steel.

Each gauge is supplied with an integrated steel “zero” plate to ensure the greatest accuracy. Supplied with a transducer & ultrasonic couplant, simply switch on the gauge and take readings. The inbuilt backlight allows measurements in low light conditions.



- Supplied with everything required to use straight from the box
- Low cost and easy to use
- Measure material thickness when there is access to only one side

### Technical Specification

**C,A** certificate available

Part Number	Description
<b>C204----1</b>	Elcometer 204 Steel Ultrasonic Thickness Gauge
Range	0.63mm to 199.99mm or 0.025" to 19.999" (switchable)
Resolution	0.01mm (0.001")
Accuracy	±2% of reading or ±0.5mm (0.02"), depending on material and conditions
Weight	295g (10oz) Including batteries
Dimensions	63 x 120 x 31mm (2.5 x 4.5 x 1.24")
Operating Temperature	-30°C to 50°C (-20°F to 120°F) depending on climatic conditions
Case	Extruded aluminium body, nickle plated aluminium end caps
Battery Life	200 hours continuous use (alkaline dry batteries)
Battery Type	2 x LR6 (AA), alkaline dry batteries
Packing List	Elcometer 204 Steel Ultrasonic Gauge, transducer with calibration certificate, ultrasonic couplant, 2 x batteries, carry case and operating instructions

*Can be used in accordance with: (see Standards Explained inside Front Cover)*

**ASTM E 797, EN 15317**

### Accessories

<b>T92015646</b>	Transducer: Potted Right Angle 5.0MHz, 6.4mm (¼") Transducer
<b>T92015701</b>	Ultrasonic Couplant - 120ml (4fl oz) Bottle
<b>T92015874</b>	High Temperature Ultrasonic Couplant - 60ml (2fl oz) Bottle
<b>T92015617</b>	Instrument Carry Case
<b>T9205243-</b>	Test Wedge: 2 - 25mm (0.07 - 0.98") in 6 Steps
<b>T9205270-</b>	Test Wedge: 30 - 100mm (1.18 - 3.93") in 8 Steps

## Elcometer 205, 206 & 206DL Ultrasonic Thickness

A range of 3 robust, hand held gauges allows you to make reliable measurements or scan a length of material for defects or the thinnest point using the scan mode.

Each gauge comes with 3 calibration options: single point, 2 point and speed of sound selection - allowing accurate measurements on a wide range of materials. Compatible with a wide range of measurement transducers (supplied separately, see page 132) these ultrasonic thickness gauges are available with or without memory and all come with a backlight for measuring in darkened environments.



### Technical Specification

**C,A** certificate available

Part Number	C205----1	C206----1	C206DL----1
Model	Elcometer 205	Elcometer 206	Elcometer 206DL
Scan Mode	■	■	■
Differential Mode		■	■
Alarm Mode		■	■
Data Output (Immediate)		■	■
Data Logging			1000 readings
ElcoMaster™ Software			■
Maximum Measurement Range	0.63 - 500mm (0.025 - 20") dependent on transducer and material		
Velocity Range	1250 - 10000m/s (0.0492 - 0.3930 in/μs)		
Accuracy	±0.01mm (0.001") dependent on material and conditions		
Resolution	0.01mm (0.001")		
Units	Millimetres and Inches		
Operating Temperature	-30°C to 50°C (-20°F to 120°F)		
Keypad Type	Sealed Membrane		
Display	114mm (4½") Digit Liquid Crystal Display with backlight		
Transducer	Select from transducer options on page 132		
Power	AA 1.5V Alkaline or 1.2V NiCad cell		
Battery Life	200 hours Alkaline/120 hours NiCad		
Weight	295g (10oz)		
Dimensions	63 x 120 x 31mm (2.5 x 4.75 x 1.25")		
Packing List	Elcometer 205, 206 or 206DL gauge, bottle of couplant, 2 x batteries, carry case, operating instructions. <i>Elcometer 206DL only: CD with ElcoMaster™ software and data transfer cable</i>		

Can be used in accordance with: (see Standards Explained inside Front Cover)

**ASTM E 797, EN 15317**

### Accessories

T92015701	Ultrasonic Couplant 120ml (4fl oz) Bottle
T92015874	High Temperature Ultrasonic Couplant 60ml (2fl oz) Bottle
T9205243-	Test Wedge: 2 - 25mm (0.07 - 0.98") in 6 Steps
T9205270-	Test Wedge: 30 - 100mm (1.18 - 3.93") in 8 Steps

## Elcometer 208 & 208DL Ultrasonic Thickness

Rugged & repeatable hand held gauges designed to non destructively measure the thickness of metal substrates whilst ignoring the thickness of up to 2mm (80mils) of an applied coating (Echo to Echo mode).

Supplied with or without data logging, each gauge can be used with the wide range of measurement transducers (supplied separately, see pages 131-132) and is supplied with a wide range of functionality including Scan mode and Alarm mode.



### Technical Specification



Part Number	C208----1	C208DL----1
Model	Elcometer 208	Elcometer 208DL
Echo-to-Echo Mode	■	■
Scan Mode	■	■
Alarm Mode	■	■
Data Output (Immediate)	■	■
Data Logging (Memory)		1000 readings
ElcoMaster™ Software		■
Maximum Measurement Range	0.63 - 500mm (0.025 - 20"), 2.54 - 25.4mm (0.1 to 1.0") in Echo-to-Echo Mode	
Velocity Range	1250 - 10000m/s (0.0492 - 0.3937 in/μs)	
Accuracy	±0.01mm (0.001")	
Resolution	0.01mm (0.001")	
Units	Millimetres and Inches	
Operating Temperature	-20°C to 50°C (-4°F to 120°F)	
Keypad Type	Sealed Membrane	
Display	114mm (4½") Digit Liquid Crystal Display with backlight	
Power	AA 1.5V Alkaline or 1.2V NiCad cell	
Weight	295g (10oz)	
Dimensions	63.5 x 120.6 x 31.75mm (2.5 x 4.75 x 1.25")	
Packing List	Elcometer 208 or 208DL gauge, bottle of couplant, battery x2, carry case and operating instructions. <i>Elcometer 208DL only: CD with ElcoMaster™ software and data transfer cable</i>	

Can be used in accordance with: (see Standards Explained inside Front Cover)

ASTM E 797, EN 15317

### Accessories

T92016967	5MHz High Damped Transducer - Steel Applications
T92016968	7.5MHz High Damped Transducer - Aluminium, Stainless Steel & Titanium Applications
T92015701	Ultrasonic Couplant, 120ml (4fl oz) Bottle
T92015874	High Temperature Ultrasonic Couplant, 60ml (2fl oz) Bottle
T9205243-	Test Wedge: 2 - 25mm (0.07 - 0.98") in 6 Steps
T9205270-	Test Wedge: 30 - 100mm (1.18 - 3.93") in 8 Steps

## Ultrasonic Transducer Options

Elcometer has a wide range of transducers available for use with the Elcometer 205, 206, 206DL, 208 & 208DL Ultrasonic Thickness Gauges. When selecting a transducer, it is important to choose one which will meet the application, taking the following into consideration:

- The type of material to be tested
- The design of the transducer probe
- The measurement range
- Whether the shape of the substrate is flat or curved or hard to reach

Please note that transducers are consumables and wear out with use. They can be replaced - please refer to the table on page 132.

- A range of frequencies and sizes is available to meet specific needs
- Straight and right angle transducers available as potted or microdot
- Potted Transducers: the transducer cable is fixed to the transducer head. These are more suitable for flatter surfaces and have a larger footprint
- Microdot Transducers: plug-in cables allow the transducer head on the cable to be replaced quickly and easily. These are more suitable for surfaces with a greater curvature and have a smaller footprint
- High Temperature transducers: temperature up to 340°C (650°F)

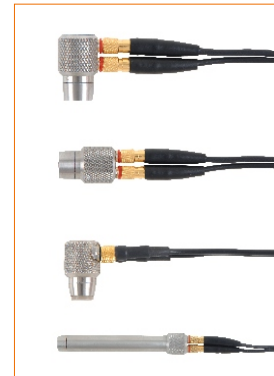

*Microdot Transducers*



*Potted Transducers*

### Definitions:

- **Microdot Transducer:**  
The cable can be unplugged from the transducer and can be easily replaced on site should it become damaged
- **Potted Transducer:**  
Unlike the microdot transducers, the cables are hard wired into the transducer head
- **Exxon Specification:**  
The gauge and transducer combination must hit specified standards without missing the first cycle

# Material Thickness

Part Number	Material											Probe Type						Measurement Range in steel		Frequency MHz (Colour Code)	Crystal Diameter		Wearface Diameter	
	Cast Iron	Plastic	Glass Fibre	Thin glass	Steel	Glass	Thin Plastic	Aluminium	Potted	Straight Probe	Right Angle	Microdot	High Temp	Extra Res	Exxon Spec	mm	inches	mm	inches		mm	inches		
T92015620	.	.	.						.	.						3.8 - 51	0.15 - 2	1.0 b/y*	12.7	0.50	15.9	0.625		
T92015621	.	.	.						.	.						3.8 - 51	0.15 - 2	1.0 b/y*	12.7	0.50	15.9	0.625		
T92015622	.	.	.						.	.						3.8 - 51	0.15 - 2	1.0 b/y*	12.7	0.50	15.9	0.625		
T92015623	.	.	.						.	.						3.8 - 51	0.15 - 2	1.0 b/y*	12.7	0.50	15.9	0.625		
T92015626	.	.	.						.	.						1.5 - 102	0.06 - 4	2.25 red	6.4	0.25	9.5	0.375		
T92015627	.	.	.						.	.						1.5 - 102	0.06 - 4	2.25 red	6.4	0.25	9.5	0.375		
T92015628	.	.	.						.	.						1.5 - 102	0.06 - 4	2.25 red	6.4	0.25	9.5	0.375		
T92015629	.	.	.						.	.						1.5 - 102	0.06 - 4	2.25 red	6.4	0.25	9.5	0.375		
T92015631	.	.	.						.	.			.			1.5 - 102	0.06 - 4	2.25 red	6.4	0.25	9.5	0.375		
T92015632	.	.	.						.	.			.			1.5 - 102	0.06 - 4	2.25 red	6.4	0.25	9.5	0.375		
T92015633	.	.	.						.	.						1.5 - 127	0.06 - 5	2.25 red	12.7	0.50	15.9	0.625		
T92015634	.	.	.						.	.						1.5 - 127	0.06 - 5	2.25 red	12.7	0.50	15.9	0.625		
T92015635	.	.	.						.	.						1.5 - 127	0.06 - 5	2.25 red	12.7	0.50	15.9	0.625		
T92015636	.	.	.						.	.						1.5 - 127	0.06 - 5	2.25 red	12.7	0.50	15.9	0.625		
T92015637	.	.	.						.	.			.			1.5 - 127	0.06 - 5	2.25 red	12.7	0.50	15.9	0.625		
T92015638	.	.	.						.	.			.			1.5 - 127	0.06 - 5	2.25 red	12.7	0.50	15.9	0.625		
T92015641				.	.	.			.	.						1.5 - 51	0.06 - 2	5.0 green	4.8	0.19	6.4	0.250		
T92015642				.	.	.			.	.						1.5 - 51	0.06 - 2	5.0 green	4.8	0.19	6.4	0.250		
T92015644				.	.	.			.	.						1.5 - 51	0.06 - 2	5.0 green	4.8	0.19	6.4	0.250		
T92015645				.	.	.			.	.						1.0 - 152	0.04 - 6	5.0 green	6.4	0.25	9.5	0.375		
T92015646				.	.	.			.	.						1.0 - 152	0.04 - 6	5.0 green	6.4	0.25	9.5	0.375		
T92015647				.	.	.			.	.						1.0 - 152	0.04 - 6	5.0 green	6.4	0.25	9.5	0.375		
T92015648				.	.	.			.	.						1.0 - 152	0.04 - 6	5.0 green	6.4	0.25	9.5	0.375		
T92015655				.	.	.			.	.			.			1.0 - 152	0.04 - 6	5.0 green	6.4	0.25	9.5	0.375		
T92015656				.	.	.			.	.			.			1.0 - 152	0.04 - 6	5.0 green	6.4	0.25	9.5	0.375		
T92015657				.	.	.			.	.						1.3 - 508	0.05 - 20	5.0 green	12.7	0.50	15.9	0.625		
T92015658				.	.	.			.	.						1.3 - 508	0.05 - 20	5.0 green	12.7	0.50	15.9	0.625		
T92015659				.	.	.			.	.						1.3 - 508	0.05 - 20	5.0 green	12.7	0.50	15.9	0.625		
T92015660				.	.	.			.	.						1.3 - 508	0.05 - 20	5.0 green	12.7	0.50	15.9	0.625		
T92015661				.	.	.			.	.			.			1.3 - 508	0.05 - 20	5.0 green	12.7	0.50	15.9	0.625		
T92015662				.	.	.			.	.			.			1.3 - 508	0.05 - 20	5.0 green	12.7	0.50	15.9	0.625		
T92015663				.	.	.	.	.	.	.						1.0 - 152	0.04 - 6	7.5 grey	6.40	0.25	9.5	0.375		
T92015664				.	.	.	.	.	.	.						1.0 - 152	0.04 - 6	7.5 grey	6.40	0.25	9.5	0.375		
T92015665				.	.	.	.	.	.	.						1.0 - 152	0.04 - 6	7.5 grey	6.40	0.25	9.5	0.375		
T92015666				.	.	.	.	.	.	.						1.0 - 152	0.04 - 6	7.5 grey	6.40	0.25	9.5	0.375		
T92015667				.	.	.	.	.	.	.				.		0.6 - 152	0.025 - 6	7.5 blue	6.40	0.25	9.5	0.375		
T92015668				.	.	.	.	.	.	.				.		0.6 - 152	0.025 - 6	7.5 blue	6.40	0.25	9.5	0.375		
T92015669				.	.	.	.	.	.	.				.		0.6 - 152	0.025 - 6	7.5 blue	6.40	0.25	9.5	0.375		
T92015670				.	.	.	.	.	.	.				.		0.6 - 152	0.025 - 6	7.5 blue	6.40	0.25	9.5	0.375		
T92015671				.			.	.	.	.						1.0 - 152	0.04 - 6	10.0 white	6.40	0.25	9.5	0.375		
T92015672				.			.	.	.	.						1.0 - 152	0.04 - 6	10.0 white	6.40	0.25	9.5	0.375		
T92015673				.			.	.	.	.						1.0 - 152	0.04 - 6	10.0 white	6.40	0.25	9.5	0.375		
T92015674				.			.	.	.	.						1.0 - 152	0.04 - 6	10.0 white	6.40	0.25	9.5	0.375		
T92015676				.			.	.	.	.						1.5 - 254	0.06 - 10	10.0 white	12.7	0.50	15.9	0.625		
T92015677				.			.	.	.	.						1.5 - 254	0.06 - 10	10.0 white	12.7	0.50	15.9	0.625		
T92015678				.			.	.	.	.						1.5 - 254	0.06 - 10	10.0 white	12.7	0.50	15.9	0.625		
T92015679				.			.	.	.	.						1.5 - 254	0.06 - 10	10.0 white	12.7	0.50	15.9	0.625		

\* b/y = Brown and Yellow



## Surface Profile

The degree of profile on the surface affects a coating's overall performance. The height of the profile (measured from the peaks to the troughs) determines aspects such as adhesion, coverage and overall volume of coating used.

If the profile is too large the amount of coating required to ensure adequate coverage increases, otherwise there is a danger that the peaks remain uncoated - allowing rust spots to occur. If the profile is too small, there may be an insufficient key to produce adequate adhesion, leading to premature coating failure.

Ensuring the correct surface preparation optimises the performance of the coating and material usage.

There are four different methods available for testing surface profile:

- **Surface Comparators:**

Surface comparators are used to compare freshly blasted profiles to pre-defined profiles. The comparators are available as grit, shot or sand and comparisons can be made visually or by touch. This method is ideal for providing a very quick guide to the profile.

- **Replica Tape :**

A foam backed plastic test piece is pressed into the blasted surface. The tape is measured to establish the surface profile. This test produces a numerical value for the profile and a proof of test, as the tape can be included in manual reports.

- **Surface Profile Gauges:**

Surface profile gauges are available in either analogue or digital versions. Once 'zeroed', the profile measurement is taken and the gauge records the value from the top of the peak to the bottom of the valley. Digital gauges minimise interpretation errors in the readings and are fast and accurate. Memory versions allow readings to be stored and later downloaded to a PC via *Bluetooth*® wireless technology.

- **Surface Roughness Testers:**

These consist of a stylus attached to an arm which moves automatically over the surface to record and measure the profile. The gauges are ideal for inspection as part of quality control during the manufacturing process, where finer profiles are produced.



## Elcometer 125 Surface Comparators

These extremely durable comparators allow the estimation of surface roughness of either grit and shot blasted surfaces. Using the Elcometer 125 surface comparators as a reference the blasted profile can be compared to the four reference profile grades in each comparator. Profiles are recorded in microns.

- 4 Roughness Values per Comparator



### Technical Specification

Part Number	Description	Section Profiles
E125----1	Elcometer Grit Surface Comparator	25, 60, 100, 150µm
E125----2	Elcometer Shot Surface Comparator	25, 40, 70, 100µm

*Can be used in accordance with: (see Standards Explained inside Front Cover)*  
 AS 3894.5, ASTM D 4417 Method A, IMO MSC.215(82), ISO 8503-1, ISO 8503-2

## Elcometer 127 Keane-Tator Surface Comparators & Magnifier

The Elcometer 127 range of Surface Comparators are available in sand, shot or grit surface profiles. Each comparator is supplied with 5 profile grades ranging from 0.5 - 4mils. Designed for use with the Elcometer 127 illuminated magnifier, each comparator has a hole in the centre allowing for clear visual comparisons to be made.

- 5 Roughness Values per Comparator



### Technical Specification

Part Number	Description	Section Profiles
E127----2	Elcometer 127 Sand Surface Comparator	0.5, 1, 2, 3, 4 mils
E127----3	Elcometer 127 Grit Surface Comparator	0.5, 1, 2, 3, 4 mils
E127----4	Elcometer 127 Shot Surface Comparator	0.5, 1, 2, 3, 4 mils
E127----1	Illuminated magnifier (x 5) with integrated surface comparator holder	-

*Can be used in accordance with: (see Standards Explained inside Front Cover)*  
 AS 3894.5, ASTM D 4417 Method A

## Elcometer 129 Rubert & Rugotest Surface Comparators

The Elcometer 129 Surface Comparators are available in two models:

- Elcometer 129 Rubert - available in grit and shot versions
- Elcometer 129 Rugotest - shot and grit profiles on the same block

Roughness is displayed in both “classes” and “roughness averages” for easier identification and are available in Metric units.

- 6 Roughness Values per Comparator



### Technical Specification

Part Number	Description	Section Profiles
E129----1	Elcometer 129/1 Rubert Grit Surface Comparator	0.4, 0.8, 1.6, 3.2, 6.3, and 12.5µm
E129----2	Elcometer 129/2 Rubert Shot Surface Comparator	0.4, 0.8, 1.6, 3.2, 6.3, and 12.5µm
E129----3	Elcometer 129/3 Rugotest Shot & Grit Surface Comparator	N6, N7, N8, N9, N10 and N11 equivalent to 0.8, 1.6, 3.2, 6.3, 12.5, and 25µm roughness averages respectively

Can be used in accordance with: (see Standards Explained inside Front Cover)

AS 3894.5

## Elcometer 133 Ship’s Propeller Comparators

The Elcometer 133 Ship’s Propeller Comparators have been developed with the specific profiles relating to the condition of a ship’s propeller.

Two versions are available; for above water (dry dock) inspection and for inspection work carried out underwater.

- 6 Roughness Values per Comparator



### Technical Specification

Part Number	Description	Section Profiles	
		Ra*	Rz*
H133--15A	Elcometer 133 Surface Comparator	1, 2, 4, 8, 16, 30µm	6, 12, 24, 48, 96, 180µm
H133--16A	Elcometer 133 Underwater Comparator	1, 2, 4, 8, 16, 30µm	6, 12, 24, 48, 96, 180µm

\*Ra = Roughness Average

\*Rz = Peak to Valley Mean Height

## Elcometer 122 Testex<sup>®</sup> Replica Tape

Elcometer 122 Testex Tape consists of foam with a non-compressible backing. The foam side is rubbed into the surface providing a permanent mould of the peak-to-valley profile, which can then be measured using the Elcometer 124 Thickness Gauge.

Elcometer 122 Testex Tape is available in three profile ranges. It is important that the tape grade chosen is reflective of the profile being measured, as using tape grade below the actual value may provide a “false” reading.

There are 50 tests in each roll.



### Technical Specification

Part Number	Description	Profile Range		Test Area Dimensions
		Metric	Imperial	
E122----B	Elcometer 122 Coarse	20 - 50µm	0.8 - 2.0mils	19 x 54mm (0.75 x 2.13")
E122----C	Elcometer 122 X-Coarse	38 - 114µm	1.5 - 4.5mils	19 x 54mm (0.75 x 2.13")
E122----F	Elcometer 122 X-Coarse Plus	115 - 152µm	4.5 - 5.0mils	19 x 54mm (0.75 x 2.13")

Can be used in accordance with: (see Standards Explained inside Front Cover)

ASTM D 4417-C, BS 7079-C5, ISO 8503-5, NACE RP0287, US Navy NSI 009-32, US Navy PPI 63101-000

## Elcometer 124 Thickness Gauge

The Elcometer 124 Thickness Gauge is used to measure the peak-to-valley height of a surface profile moulded in the Elcometer 122 Testex Replica Tape.

- Available in both Metric and Imperial versions
- Quick and easy to use
- Anvil pressure as required in the Standards



### Technical Specification

**C,A** certificate available

Part Number	Description	Range	Dimensions	Weight	Scale Resolution
E124---3M	Elcometer 124 Metric	0.5mm	120 x 95 x 25mm	260g	2µm
E124---3E	Elcometer 124 Imperial	0.2"	4.6 x 3.6 x 1.0"	9oz	0.1mil

Can be used in accordance with: (see Standards Explained inside Front Cover)

ASTM D 4417-C, BS 7079-C5, ISO 8503-5, NACE RP 0287, US Navy NSI 009-32, US Navy PPI 63101-000

## Elcometer 224 Digital Surface Profile Gauge

The Elcometer 224 provides the very latest in surface profile measuring technology. Accurate, fast and very user friendly, this gauge is available with or without memory. The Elcometer 224 Top model is available with *Bluetooth*® wireless technology and can store up to 50,000 readings in 999 batches.



Fast reading rate at 40+ readings per minute.

Cost per test is significantly lower than other test methods.

*Bluetooth*® wireless technology & RS232 data output for cable free data transfer.;

Store up to 50,000 readings in 999 batches.

Readings can be downloaded to a PC and reports created in seconds.

Statistics are calculated and displayed in real time.

Counted average mode stores the average value of a preset number of readings.

Accurate, immediate and repeatable results.

Intuitive menus in multiple languages enables use straight from the box.

Large backlit screen makes viewing readings easy.

Digital display prevents reading interpretation errors.

Measure profiles up to 500µm (20 mils) in a single gauge.

Tough tungsten carbide user replaceable tip, can be used for up to 20,000 readings.



## Elcometer 224 S Digital Surface Profile Gauge

The Elcometer 224 S Digital Surface Profile Gauge provides an accurate way to measure surface profiles in microns and mils and is an ideal gauge for checking the quality of the surface profile.

The gauge displays statistical values as readings are taken, giving rolling statistics.

The intuitive menu system, in over 20 languages, makes this gauge user friendly.

The tungsten carbide tip will last for up to 20,000 readings and can then be easily replaced by the user in the field.



## Elcometer 224 T Digital Surface Profile Gauge

The Elcometer 224 T works in the same way as the Elcometer 224 S, but has the advantage of a large inbuilt memory to accurately record each measurement and offers *Bluetooth*<sup>®</sup> wireless technology for cable free data transfer.

The memory is able to store up to 50,000 readings in 999 batches. This enables readings to be automatically stored - ideal for measuring large surface areas.

A statistical analysis is also displayed on the gauge and stored within each batch.

Data can be downloaded to a PC and, using the ElcoMaster<sup>™</sup> Software (supplied free of charge with this gauge - see page 138), detailed reports can be created in seconds. Data can also be transferred to a spreadsheet. With the supplied ElcoMaster<sup>™</sup> & ElcoMaster<sup>™</sup> Mobile Software, you are able to e-mail data directly to the office from the field with a PDA.

The Elcometer 224 T operates in one of three modes; immediate, batch or counted average.

- **Immediate mode:** Takes readings and calculates statistics but does not store any readings in the memory (this is known as rolling statistics).
- **Batch mode:** Takes measurements and stores the individual readings and the statistical analysis in the memory. Batch mode, or batching, allows data to be collected in groups to allow easier analysis of large or complex structures. The Elcometer 224 T has the memory capacity for a total of 50,000 readings in up to 999 batches.
- **Counted average mode:** Automatically calculates the average value of a pre-determined number of readings. Each of these averages is recorded within the batch and stored in the memory.



## Elcometer 224 Technical Specification

### Technical Specification

**C,A** certificate available

Model	Elcometer 224 S	Elcometer 224 T
Part Number	E224----S	E224----T
Multi Language Menus	▪	▪
Backlit Screen	▪	▪
Field Replaceable Tip	▪	▪
Rolling Statistics	▪	▪
Bluetooth® Wireless Technology		▪
RS232 Data Output	▪ (a)	▪ (b)
Stored Statistics		▪
Memory (50,000 Readings in up to 999 Batches)		▪
High/Low Reading Limits		▪
Batching Mode		▪
Batch Review		▪
ElcoMaster™ Software		▪
Range	0µm - 500µm (0mils - 20mils)	
Accuracy	±5% or ±5µm (±0.2mil)	
Resolution	1µm (0.1mil)	
Measurement Speed	>40 readings per minute	
Operating Temperature	0°C to 50°C (32°F to 120°F)	
Storage Temperature	-10°C to 55°C (14°F to 130°F)	
Dimensions	140 x 75 x 35mm (5.5 x 3 x 1.38")	
Weight	180g (5.7oz)	
Packing List	Elcometer 224 S gauge, zero plate, carry pouch, probe protection cap, batteries and operating instructions	
	Elcometer 224 T gauge, zero plate, carry pouch, probe protection cap, batteries, ElcoMaster™ Software and operating instructions	

Can be used in accordance with: (see Standards Explained inside Front Cover)

ASTM D 4417-B, IMO MSC.215(82), NSI 0009-32, NSTM CH 631, SMS 6310-081-015, SANS 5772, US Navy NSI 009-32, US Navy PPI 63101-000

(a) Data output only available as each reading is taken.

(b) Data output as each reading is taken from memory.

### Accessories

T22420053	Replacement Tip (Pack of 2) with Fixing Tool
T22420054	Replacement Tip (Pack of 2)
T22420095	Replacement Tip (Pack of 5)
T22419793	Probe Tip Protection Cap
T22420072	Glass Zero Plate with Wallet
T99920130	USB PC Bluetooth® Transmitter/Receiver (for Elcometer 224 T)

## ElcoMaster™ Data Management Software

ElcoMaster™ makes it easy for you to collate and use the data you record and is provided free of charge with the Elcometer 224 Top Gauge.

Whether you want to use the data for analysis or to create professional reports for distribution to customers or colleagues, ElcoMaster™ can help. With in-built report templates and easy access of all data, images and other associated files, ElcoMaster™ makes managing your data simple.

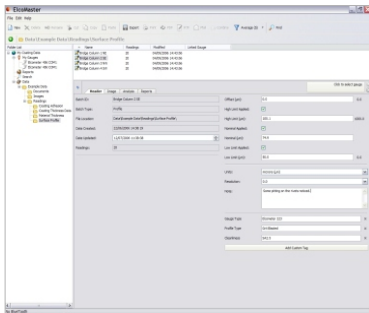

The software has been designed to be familiar and intuitive to any PC user. When the gauge is connected to the PC, individual readings can be sent directly into the software for real time analysis or simply 'drag and drop' a batch from the gauge to the software.

All associated job or inspection files, health and safety reports etc. can be stored within ElcoMaster™. One programme holds all of your inspection information in one place.

Viewing data and producing standard reports is achievable in just a few clicks. Fully customised reports can be produced quickly by using the ElcoMaster™ Report Designer.

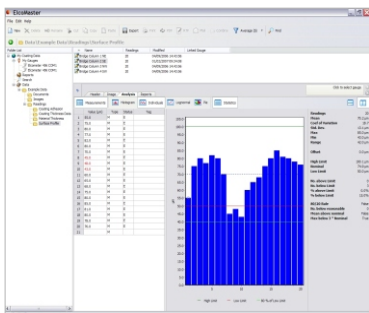

In addition to the readings and charts, a digital photograph may be assigned to an individual batch of data, allowing the visual display of the inspection area in reports. Batches can be combined for immediate comparison of data from various areas of the job site.

ElcoMaster™ features include:

- Create professional reports in seconds
- Export reports to spreadsheets, text files or save as PDF or JPEG files
- Copy and paste reports into other documents
- Reports can be combined in order to clearly compare different batches
- E-mail reports directly from ElcoMaster™
- Supports gauges with *Bluetooth*® wireless technology
- Assign batch identification tags
- Batches can be renamed to clearly identify the inspected work
- Wide range of standard reports include;
  - Individual measurements
  - Statistics
  - Histograms
  - Individual line or bar charts
  - Log normal
  - Pie charts
- Fully customise reports using the ElcoMaster™ Report Designer tool
- Include company graphics and logos on every report
- Combine batches to compare readings or link batches together from different gauges into one comprehensive inspection file
- "Find" feature to quickly locate a specific file or batch

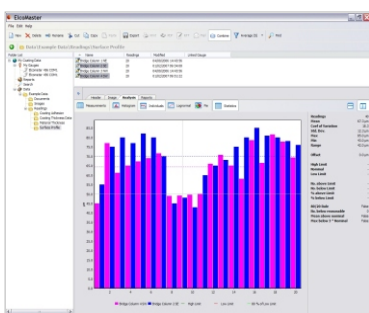
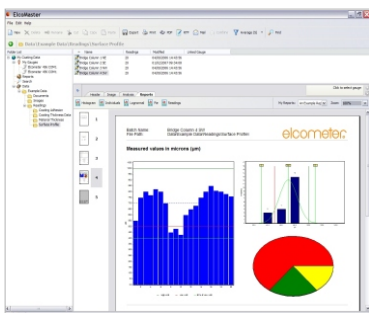



## Elcometer 223 Digital Surface Profile Gauge

A Digital Surface Profile Gauge which measures the peak-to-valley height of a surface in a similar way to the Elcometer 224.

- RS232 output - for direct transfer of readings to a PC, datalogger, miniprinter etc. Provides a permanent record of your test results (no memory in the gauge)
- Metric and Imperial switchable



### Technical Specification

**C,A** certificate available

Part Number	Description
<b>E223---2</b>	Elcometer 223 Digital Surface Profile Gauge
Range	0 - 1000µm (0 - 40mils)
Scale	1µm (0.1mil)
Power Supply	3V Lithium CR2032 Battery
Dimensions	105 x 55 x 25mm (4.1 x 2.2 x 1")
Weight	365g (9oz)
Packing List	Elcometer 223 Digital Surface Profile Gauge, glass slide, 2mm allen key, carry case and operating instructions

Can be used in accordance with: (see Standards Explained inside Front Cover)

ASTM D 4417-B, IMO MSC.215(82), NSTM 009-32, SANS 5772, US Navy NSI 009-32, US Navy PPI 63101-000

## Elcometer 123 Surface Profile Gauge

This easy to use gauge measures the peak-to-valley height of a blast cleaned surface.

The average of a series of measurements provides an indication of the surface roughness and allows the surfaces to be compared as blasting proceeds.

- Metric and Imperial versions



### Technical Specification

**C,A** certificate available

Part Number	Description
<b>E123A--M-</b>	Elcometer 123 Surface Profile Gauge, Metric Version
<b>E123A--E-</b>	Elcometer 123 Surface Profile Gauge, Imperial Version
Range	0 - 1000µm (0 - 40mils)
Scale	2µm (0.1 mil)
Dimensions	105 x 55 x 25mm (4.1 x 2.2 x 1")
Weight	335g (8oz)
Packing List	Elcometer 123 Surface Profile Gauge, glass slide, 2mm allen key, carry case and operating instructions

Can be used in accordance with: (see Standards Explained inside Front Cover)

ASTM D 4417-B, IMO MSC.215(82), NSTM 009-32, SANS 5772, US Navy NSI 009-32, US Navy PPI 63101-000

## Elcometer 7060 SURFTEST SJ-201P Roughness Tester

A portable device operating on the inductive principle to measure the roughness of a variety of surfaces. This instrument consists of a processing unit with a digital display of the current parameters and a mobile measurement head which is fitted with a retractable diamond stylus sensor (5µm /0.2mils radius) and has a working load of 4mN. The roughness profiles are determined by motorised travel of the sensor over the surface to be tested.

Each unit is supplied with a roughness reference standard, case, tools and mains adaptor.

### Features:

- Sampling lengths: 0.25, 0.8, 2.5mm (0.01, 0.03, 0.1")
- Number of sampling spans: x1, x3, x5



### Technical Specification



Part Number	Description
<b>K0UK7060M003</b>	Elcometer 7060 SURFTEST SJ-201P Roughness Tester, UK 240V
<b>K0007060M003</b>	Elcometer 7060 SURFTEST SJ-201P Roughness Tester, EUR 220V
Roughness Parameters	A1, A2, Mr, Mr1, Mr2, Pc, R3z, Ra, Rk, Rp, Rpk, Rq, Rt, Rvk, Ry, Rz, S, Sm, Vo.
Measurement Range	Ra 0.01 to 100µm (0 to 4mils), Ry/Rz 0.02 to 300µm (0 to 12mils)
Measurement Length	0.25, 0.8, 2.5mm (0.01, 0.03, 0.1")
Data Output	RS232
Power Supply	Internal rechargeable battery NiCad providing approximately 500 measurements
Weight	0.5kg (1.1lb)
Dimensions	50 x 62 x 157mm (2 x 2.4 x 6.2")
Packing List	Elcometer 7060 SURFTEST SJ-201P Roughness Tester, adaptor, connection cable, screwdriver, stylus, precision roughness specimens, carry case and operating instructions

Can be used in accordance with: (see Standards Explained inside Front Cover)

**ISO 3274**

## Elcometer 7060/4 SURFTEST SJ-301 Roughness Tester

The new generation, high performance, roughness unit works on the same principle as the Elcometer 7060 but is fitted with an inbuilt printer and a large LCD touch panel for numeric/graphic display and settings.

Each unit is supplied with standard sensor and accessories, AC adaptor and roughness specimen.

Features:

- Analysis graphs: BAC1, BAC 2, ADC
- Statistics: minimum, maximum, standard deviation, pass ratio, frequency distribution
- Adjustable limits

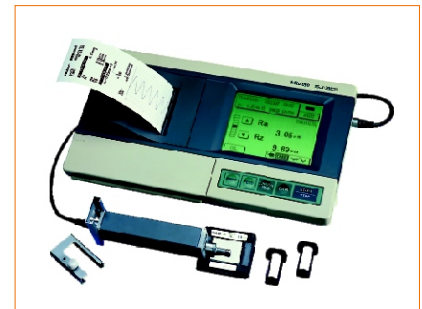

### Technical Specification

**C** certificate available

Part Number	Description
K0UK7060M002	Elcometer 7060/4 SURFTEST SJ-301 Roughness Tester, UK 240V
K0007060M002	Elcometer 7060/4 SURFTEST SJ-301 Roughness Tester, EUR 220V
Roughness Parameters	Ra, Ry, Rz, Rt, Rq, Rv, Sm, S, Pc, R3z, mr, Rpk, Rvk, Rk, Mr1, Mr2, Lo, Ppi, R, AR, Rx, A1, A2.
Measurement Range	Ra 0.01 to 75µm (0 to 3mils) Ry/Rz 0.02 to 30µm (0 to 12mils)
Measurement Length	0.08, 0.25, 0.8, 2.5, 8mm (0.003, 0.01, 0.03, 0.1, 0.31")
Data Output	RS232
Power Supply	Internal rechargeable NiCad battery providing approximately 500 measurements
Weight	1.4kg (3.1lb)
Dimensions	156 x 62 x 52mm (61 x 24 x 20")
Packing List	Elcometer 7060 SURFTEST SJ-301 Roughness Tester, adaptor, connection cable, touch pen, precision roughness specimens, AC adaptor, power cable, screwdriver, carry case and operating instructions

Can be used in accordance with: (see Standards Explained inside Front Cover)

ISO 3274

## Elcometer 119 Pipe Pit Gauge

The Elcometer 119 Pipe Pit Gauge is a pocket sized gauge designed to identify the condition of a pipe.

The gauge is placed horizontally on the surface of the pipe and the stylus is positioned into the base of the corrosion pit.

The gauge shows the pit depth compared to the nominal pipe wall thickness. Imperial units only.



### Technical Specification

Part Number	Description
<b>E119-----</b>	Elcometer 119 Pipe Pit Gauge
Range	0 - 500mils (0 - 0.5")
Graduation	10mils and 1/16"
Dimensions	68 x 133 x 4mm (21 x 5.25 x 0.18")
Weight	227g (8oz)

Customers who purchased the Pipe Pit Gauge also purchased:



◀ Elcometer 204 Steel Ultrasonic Gauge, page 128

Elcometer 266 Pinhole & Porosity Gauge, page 231 - 235



## Surface Cleanliness

During the initial surface preparation, in addition to brushing or grinding, a coated surface can be blasted, high pressure water-jetted or simply washed down. In many cases, the abrasive media or water is recycled. In these instances, it is important that the level of contaminants in the recycled material is carefully monitored to avoid the re-contamination of the surface being cleaned.

Surface contamination from salt ions such as chlorides, sulphates and nitrates has been shown to lead to delamination, blistering and premature coating failure. The measurement of the cleanliness of a surface prior to the application of a coating is, therefore, necessary to ensure the substrate, or coated surface in multi-layer systems, is clean of all contaminants prior to the application of the next coating.

A range of field tests is available to ensure surface cleanliness:

- Dust Test Kits
- Chloride Ion Specific Test Kits for Abrasives and Water
- Chloride Ion Specific Test Kits for Surface Cleanliness
- Soluble Salt Testing Kits - using the Bresle Patch Method
- Soluble Salt Test - using the Salt Contamination Meter
- Surface Contamination Test Kits
  - for testing levels of chloride, sulphate and nitrate ions
  - for testing levels of pH, iron, chlorides and soluble salts

The visual inspection of a surface is also required and a range of Pictorial Standards has been produced to aid both operators and inspectors.



## Elcometer 142 ISO 8502-3 Dust Tape Test Kit

The Elcometer 142 Dust Tape Test kit allows assessment of the quantity and size of dust particles on surfaces prepared for painting. Dust on blast cleaned surfaces can reduce coating adhesion, leading to premature coating failure and sub-standard coating finish.

The kit can be used in accordance with the recommendations of BS EN ISO 8502-3 either as a pass/fail test or as a permanent record of the presence of dust. Supplied in a carry case for use in the field to assess surface cleanliness.



### Technical Specification

Part Number	Description
<b>E142----</b> 1	Elcometer 142 ISO 8502-3 Dust Tape Test Kit
Measuring Range	Chart with dust classes ranging from 0 - 5 with descriptions for accurate class placement
Dimensions	210 x 297mm
Weight	250g (9oz)
Packing List	Microscope with 10x magnifier, 2 batteries (LR14), graticule, adhesive tape to specification ISO 8502-3, comparator display board, dust assessment plate, test record sheets (pack of 25) and operating instructions

## Elcometer 134A Chloride Ion Test Kit for

Chlorides deposited on a surface by contaminated abrasives during blasting can cause a coating to fail prematurely.

Contamination can build up, particularly if the blast media is recycled several times. Using the Elcometer 134A Chloride Ion Test in the field will accurately identify contamination and prevent costly surface-related failures.



### Technical Specification

Part Number	Description
<b>E134----</b> 2	Elcometer 134A Chloride Ion Test Kit for Abrasives
Measuring Range	0 - 50µg/cm <sup>2</sup> (0 - 50ppm)
Scale Resolution	1µg/cm <sup>2</sup> (1ppm)
Sample Time	1.5 minutes (approx)
Tests per Kit	4
Storage Conditions	Not exceeding 25°C (77°F)
Dimensions	185 x 125 x 110mm (7 x 5 x 4.5")
Weight	367g (13oz)
Packing List	4 x test kits, containing: abrasive sample container, mixing container with a pre-measured quantity of solution, titration tube, titration tube snapper, strap and operating instructions

## Elcometer 134W Chloride Ion Test Kit for Water

If the chloride levels in the wash water are too high, this will promote premature corrosion, shortening the life of both steel and concrete structures.

Used to monitor recycled water (after it has been applied) to establish effectiveness of salt removal, this test is ideal when mixing concrete and when washing steel.



### Technical Specification

Part Number	Description
<b>E134----3</b>	Elcometer 134W Chloride Ion Test Kit for Liquids
Measuring Range	10 - 2000µg/cm <sup>2</sup> (10 - 2000ppm)
Scale Resolution	10µg/cm <sup>2</sup> (10ppm)
Sample Time	1.5 - 4 minutes (approx)
Test per Kit	5
Storage Conditions	Not exceeding 25°C (77°F)
Dimensions	185 x 125 x 110mm (7 x 5 x 4.5")
Weight	208g (7oz)
Packing List	5 x test kits each containing: sample container bottle with dropper in lid, titration tube, titration tube snapper and operating instructions

## Elcometer 134S Chloride Ion Test Kit for Surfaces

Chloride salts left on the surface before the first coat is applied can result in the coating system being forced off the surface by corrosion or blistering before the full life of the coating has been reached. To ensure that the chloride has been removed it is essential that the surface is tested before the coating is applied.

Elcometer 134S test method: a latex sleeve is filled with a Chlor\*Rid extract solution and stuck to the test surface where the solution is worked against the surface to extract the salts. The titration tube is inserted and the results can be recorded.



### Technical Specification

Part Number	Description
<b>E134----1</b>	Elcometer 134S Salt Detection Kit for Blast Cleaned Surfaces
Measuring Range	0 - 500µg/cm <sup>2</sup> (0 - 500ppm)
Scale Resolution	1µg/cm <sup>2</sup> (1ppm)
Tests per Kit	4
Dimensions	185 x 125 x 110 mm (7 x 5 x 4.5")
Weight	250g (9oz)
Packing List	5 x test kits each containing: titration tube snapper, strap, clip, pre-measured bottle of Chlor*Rid extract solution, sleeve, titration tube and operating instructions

*Can be used in accordance with: (see Standards Explained inside Front Cover)*

**ISO 8502-5, SSPC Guide 15**

## Elcometer 138 Conductivity Meter

Incorporating a flat sensor, the Elcometer 138 Conductivity Meter can measure the conductivity of a solution from a single drop of a sample.

Users can either place a sample on the meter's flat sensor or immerse the meter directly in the solution being tested, giving the meter a broad range of applications, for example, measuring rainwater pollution levels or the electric conductivity (EC) of solutions used in agricultural operations.

Also, the Elcometer 138 Conductivity Meter includes a convenient salinity conversion indicator. The meter can be directly immersed in solutions to take measurements, enabling convenient testing of such solutions as river water.

Features:

- Highly precise measurements can be obtained from a single-drop sample
- Waterproof flat sensor
- Automatic range switching gives a wide measurement range of 1µs/cm to 19.9mS
- When the conductivity value is above 20 mS/cm or the salinity is above 1.1%, the display will flash
- Battery Alarm when the battery is low
- The "°C" indicator light appears when the sample is below 5°C (41°F) or above 35°C (95°F)
- Displays Conductivity (mS/cm) and/or Salinity (%)



### Technical Specification

Part Number	Description
<b>T13818515</b>	Elcometer 138 Conductivity Meter
Measuring Range	2% full scale ±1 digit. At a depth of more than 10ms/cm, the range is 3% full scale ±1 digit
Repeatability	±1% full scale
Ambient Temperature	5°C - 35°C
Accuracy	±2% full scale ±1 digit (over 10 mS/cm: ±3% full scale ±1 digit)
Dimensions	150 x 27 x 16mm (6 x 1 x 0.6")
Weight	47g (1.7oz)
Packing List	2 x bottles of standard solution (1.41mS/cm), bottle of de-ionised water, 2 x CR-2032 lithium batteries, pipette, storage pouch and operating instructions

*Can be used in accordance with: (see Standards Explained inside Front Cover)*

**ISO 8502-6, ISO 8502-9, ISO 8502-11, AS 3894.6-A, SSPC Guide 15, US Navy NSI 009-32, US Navy PPI 63101-000**



## Elcometer 138 Bresle Salt Kit

It is essential that the level of contaminants on a surface is measured prior to application of the coating to ensure the quality of the coating and that its optimum lifetime is achieved.

If the coating is applied to a contaminated surface, which is not properly prepared, it could fail prematurely resulting in costly re-coating and high maintenance costs.

The Elcometer 138 Bresle Kit includes the Elcometer 138 Conductivity Meter. This lightweight, portable conductivity meter accurately measures the salinity of the test samples.

The cartridge type sensor can be easily replaced when necessary and displays conductivity (mS/cm) and salinity (%) on the digital display.

Features of the meter include indication of stability of reading indication, temperature warning and simple calibration.



### Technical Specification

Part Number	Description
<b>E138----</b> 1	Elcometer 138 Bresle Salt Kit
Tests per Kit	25
Dimensions	300 x 220 x 75mm (11 x 8.6 x 3")
Weight	2.1kg (4.62lb)
Measuring Range	2% full scale $\pm 1$ digit. At a depth of more than 10ms/cm, the range is 3% full scale $\pm 1$ digit
Packing List	Box of 25 x Elcometer Bresle patches, 250ml pure water in clear plastic bottle, 3 x 5ml (0.1fl oz) syringes, 3 x blunt needles, 30ml (1fl oz) plastic beaker, Elcometer 138 Conductivity Meter, 2 x CR2032 lithium batteries, 2 x standard solution (1.41 mS/cm), moistening solution, purified water, pipette, conductivity meter storage pouch, carry case and operating instructions

*Can be used in accordance with: (see Standards Explained inside Front Cover)*

ISO 8502-6, ISO 8502-9, ISO 8502-11, AS 3894.6-A, SSPC Guide 15, US Navy NSI 009-32, US Navy PPI 63101-000

### Accessories

<b>E135----</b> B	Bresle Patches (Box of 25)
<b>T13818517</b>	3 x 5ml (0.1fl oz) Syringes
<b>T13818518</b>	3 x Needles
<b>T13818519</b>	Plastic Beaker 30ml (1fl oz)
<b>T13818516</b>	4 x Calibration Standards Solution
<b>T99911344</b>	Pure Water 250ml (8.5fl oz)

## Elcometer 135A Bresle Sampler

The Elcometer 135A Bresle Sampler is a self-adhesive rubber film patch with a sealed compartment for sampling of soluble impurities from steel surfaces with our extraction liquid. The Elcometer 135A Bresle Samplers are also part of the Elcometer 138/2 Surface Contamination Kit, see page 153.



### Technical Specification

Part Number	Description
<b>E135----A</b>	Elcometer 135 Bresle Sampler
Tests per Kit	50
Test Area	1250mm <sup>2</sup> , 12.5cm <sup>2</sup> (1.93sq inches)
Dimensions	52 x 52cm (2.0 x 2.0")
<i>Can be used in accordance with: (see Standards Explained inside Front Cover)</i>	
ISO 8502-6	

## Elcometer 135B Bresle Patches

The Elcometer 135B Bresle Patches are required to determine the surface chloride contamination. The Elcometer Bresle Patches are also available as part of the Elcometer 138 Bresle Salt Kit, see page 149.



### Technical Specification

Part Number	Description
<b>E135----B</b>	Elcometer 135 Bresle Patches
Tests per Kit	25
Test Area	1250mm <sup>2</sup> , 12.5cm <sup>2</sup> (1.93sq inches)
Sample Volume	1.5ml to 2.0ml
Dimensions	52 x 52mm (2.0 x 2.0")

## Elcometer 130 Salt Contamination Meter

Soluble salts on a surface are absorbed into a special filter paper soaked with distilled water. The Elcometer 130 measures the conductivity of the wet paper, calculates the salt level and displays it in  $\mu\text{g}/\text{cm}^2$ .

- Suitable for a wide range of shapes, orientations, surfaces and finishes
- Quick and simple to use
- Battery operated and portable
- Confirms adequate cleaning of surfaces before coating, aiding the prevention of premature coating failure
- Shows salt build-up on vulnerable surfaces, which can be cleaned to increase the lifetime of a coating
- Test papers can be re-moistened and a similar test result can be achieved;; ideal for proof and ISO requirements
- Accurate
- Repeatable
- Reproducible



### Technical Specification



Part Number	Description
<b>E130----1</b>	Elcometer 130 Salt Contamination Meter
Range	0.1 - 20 $\mu\text{g}/\text{cm}^2$
Resolution	0.1 $\mu\text{g}/\text{cm}^2$
Accuracy	$\pm 10\%$
Operating Range	5°C - 40°C (41°F - 104°F) <80% RH
Power Supply	9V Battery 6LR61 (MN1604)
Number of Tests	Approximately 500 measurements before recharge
Sample Time	2 minutes
Sampling Size	110mm (4.3") circle, or part of
Dimensions	200 x 190 x 60 mm (7.9 x 7.5 x 2.4")
Weight	1.5kg (3.3lb)
Packing List	Elcometer 130 Salt Contamination Meter, 100 x high purity test papers, 250ml (8.5fl oz) pure water, 8 x replacement plate support pads, 20 x PVC storage bags, disposable gloves, tissues, 3 x 2ml (0.06fl oz) syringes, plastic tweezers, plastic sample bottle, carry case and operating instructions

Can be used in accordance with: (see Standards Explained inside Front Cover)

**SSPC Guide 15**

### Accessories

<b>T99911344</b>	Pure Water - 250ml (8.5fl oz) Bottle
<b>T1304469-</b>	100 High Purity Test Papers
<b>T1304472-</b>	Medical Wipes (1 Pack)

## Elcometer 134 CSN Chloride, Sulphate & Nitrate Kit

Designed to accurately, measure surface chloride, sulphate and nitrate ions in minutes, the Elcometer 134 CSN Salt kit offers a single kit solution for testing in the field.

All the components of the Elcometer CSN Test Kits are pre-measured and pre-dosed for trouble free testing.

Results are recorded in parts per million (ppm) requiring no complicated calculations. Elcometer 134 CSN tests are all designed to use a ratio of 1:1 for easy conversion to  $\mu\text{g}/\text{cm}^2$ .

Supplied in an ABS plastic carry case for easy portability around the site, each field kit is supplied with full instructions attached to the inside lid, together with:

- 5 x Chloride tests
- 5 x Sulphate tests, together with 1 x colorimeter, for sulphate testing
- 5 x Nitrate test strips
- 5 x Syringes (without needles)

Refill kits are available for all consumables.



### Technical Specification

Part Number	Description
<b>E134-CSN</b>	Elcometer 134 CSN Chloride, Sulphate & Nitrate Test Kit
Measuring Range	0 - 100 $\mu\text{g}/\text{cm}^2$ (0 - 100ppm)
Scale Resolution	1 $\mu\text{g}/\text{cm}^2$ (1ppm)
Sample Time	1 - 5 minutes (approximately)
Storage Temperature	Not exceeding 25°C (77°F)
Dimensions	360 x 320 x 140mm (14.2 x 12.6 x 5.5")
Weight	1.76kg (3.8lb)
Packing List	5 x tests (containing: 5 x chloride tests, 5 x nitrate test strips, 5 x sulphate tests, 5 x syringes), 1 x colorimeter, carry case and operating instructions

*Can be used in accordance with: (see Standards Explained inside Front Cover)*

**ISO 8502-5, NACE 6G186, NACE 6,SSPC SP13, SSPC Guide 15**

### Accessories

<b>T134---C</b>	1 set of 5 Nitrate Tests
<b>T134-KIT</b>	Refill Kit for Elcometer 134 CSN

## Elcometer 138/2 Surface Contamination Kit

The Elcometer 138/2 Surface Contamination Kit provides the user with a means for testing invisible surface contaminants including:

- pH
- chloride ions
- iron
- salts



### Technical Specification

Part Number	Description
<b>E138----2</b>	Elcometer 138/2 Surface Contamination Kit
Measuring Range	pH: 0pH to 14pH Iron: 3 - 10 - 25 - 50 - 100 - 250 - 500mg/l Fe <sup>2</sup> Chloride: 30µg/cm <sup>2</sup> (30ppm) Cl to 600µg/cm <sup>2</sup> (600ppm) Cl
Dimensions	300 x 220 x 75mm (11 x 8.6 x 3")
Weight	2.1kg (4.62lb)
Packing List	100 x pH test strips, 100 x Iron test strips, 40 x Chloride test strips, 50 x Bresle samplers, 3 x 5ml (0.2fl oz) syringes, 3 x needles, 30ml (1fl oz) plastic beaker, carry case and operating instructions
<i>Can be used in accordance with: (see Standards Explained inside Front Cover)</i>	
ISO 8502-6, SSPC Guide 15	

### Accessories

<b>E135----A</b>	Bresle Sampler (Box of 50)
<b>T13818517</b>	3 x 5ml (0.1fl oz) Syringes
<b>T13818518</b>	3 x Needles
<b>T13818519</b>	Plastic Beaker, 30ml (1fl oz)
<b>T99911344</b>	Pure Water, 250ml (8.5fl oz)
<b>T13820562</b>	100 x pH Test Strips
<b>T13820563</b>	100 x Iron Test Strips
<b>T13820564</b>	40 x Chloride Test Strips

## Elcometer 128 Pictorial Surface Standards

Elcometer’s range of Surface Standards covers most of those required for surface cleanliness.

Surface Standards include:

- The Swedish Standard - ISO 8501, SIS 055900
- The SSPC Standard - VIS 1-01
- The SSPC Standard - VIS 2
- The SSPC Standard - VIS-3
- The SSPC Standard - VIS 4
- The SSPC Standard - VIS 5
- BS EN ISO 8501-4:2006



### Technical Specification

Part Number	Description
E128----1	Swedish standard (ISO 8501-1, SIS 055900) - the original visual standard. It shows the degree of cleanliness of different levels of rusted steel cleaned by blasting, hand and power tools and flame, specified by ASTM D2200 Method A
E128----3	SSPC (steel structures painting council) VIS 1-01 - similar to the Swedish and British standards, but the pictures of the required final appearances match the written descriptions in the USA standards. VISI 1-89 includes photographs of surfaces cleaned using metallic and non-metallic abrasives. Specified by ASTM D2200 Method B
E128----5	SSPC VIS-3 - contains 44 photographs to supplement the written SSPC specifications for hand and power tool cleaning
E128----6	SSPC VIS2 Standard method of evaluating the degree of rusting on painted steel surfaces
E128----7	SSPC VIS4 Guide and reference photographs for steel surfaces prepared by waterjetting
E128----8	SSPC VIS5 Guide and reference photographs for steel surfaces prepared by wet abrasive
E128----9	BS EN ISO 8501-4:2006 - preparation of steel substrates before application of paints and related products. Visual assessment of surface cleanliness. Initial surface conditions, preparation grades and flash rust grades in connection with high-pressure water jetting

Can be used in accordance with: (see Standards Explained inside Front Cover)

ASTM D 2200, BS EN ISO 8501-4 2006, IMO MSC.215(82), ISO 8501-1, SIS 055900, SSPC VIS 1, SSPC VIS 2, SSPC VIS 3, SSPC VIS 4, SSPC VIS 5, US Navy NSI 009-32

Customers who purchased the Elcometer 128 have also purchased:

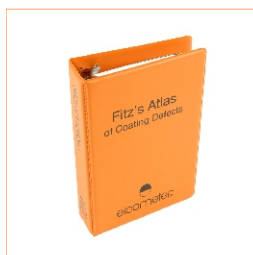

◀ Elcometer Fitz Atlas, page 243  
Elcometer 224 Surface Profile Gauge, page 137 - 140 ▶



## Climatic Testing

The monitoring of climatic conditions such as temperature, relative humidity, dewpoint and moisture in industry is often vital to the success of the application of a coating. These parameters determine both the conditions for the application of the coating, and the resulting quality and performance of the coated product.

In the protective coatings industry, moisture can form on the surface when the surface temperature is low enough to cause condensation from the atmosphere. The Dewpoint temperature ( $T_d$ ) is the point at which this occurs.

Monitoring the surface temperature ( $T_s$ ) relative to the air temperature ( $T_a$ ) and its relative humidity (%RH) allows the dewpoint temperature to be calculated and compared to the surface temperature. This difference in temperature ( $T\Delta$ ) is the key parameter dictating when it is safe to apply the coating.

The temperature of the coating material is also important as temperature affects the coating's shelf life, viscosity and its application characteristics.

The continuous monitoring of the climatic conditions during the cure process (drying) is also required. If the temperature is too high, the coating can dry too quickly, leading to surface defects. If the temperature is too low, the cure time is extended, leading to delays in applying a further coat, other types of surface defects may affect the further coat, such as amine blush.

The cure process for powder coating requires a specific temperature to be achieved for a specific period. Monitoring the oven profile allows the user to ensure that the product is brought to the appropriate temperature and held at that temperature for the specified time. If the oven or product is too hot, the coating can burn, if it is too cold, the coating does not cure, leading to poor adhesion and appearance.

The presence of moisture within a material will result in poor adhesion, premature coating failure and poor appearance. For example, applying a powder coating to a damp wooden panel will cause steam to be created when the panel passes through the curing oven, thus causing damage to the coating.



## Elcometer 319/2 Dewpoint Meter

The Elcometer 319/2 is an extremely versatile digital Dewpoint Meter for measuring and recording the climate parameters required to ensure good quality coating applications.

Ideal for use in construction and building maintenance, coatings and paint, galvanised and steel protection industries.

Measure and record climatic parameters including: Relative humidity, Air temperature, Surface temperature, Dewpoint and the difference between surface temperature and dewpoint,  $T\Delta$

Evaluate digital data on screen or export to a PC using the optional Docking Unit

Integrated flash light to illuminate the surface being measured

Hi/Low audio and visual alarms for when limits are exceeded

Large, illuminated digital display with easy to use menu

Single handed operation

Store up to 12,000 records in up to 8 batches

Data can be date and time stamped

Battery life of up to 400 hours continuous use



The Docking Unit acts as a magnetic holder on ferrous substrates, ideal for continuous data logging





### **Simple**

- Single handed operation
- Easy menu-driven user interface in multiple languages
- Clear, illuminated display shows battery status and all five parameters; Ts: Surface Temperature, RH%: Relative Humidity, Ta: Ambient Air Temperature, Td: Dewpoint, and TΔ: the difference between the Dewpoint and Surface Temperatures



### **Durable**

- Durable industrial sensors are combined with calibration procedures
- Rugged gauge for harsh environments
- Rubber injected case for protection and firm grip
- Surface probe supported by thermal conductive rubber



### **Flexible**

- Visual and audible alarms whenever a limit is exceeded
- Hold/freeze function allows the readings to be taken and reviewed before being logged to memory
- Celsius/Fahrenheit switchable
- Readings can be time & date stamped



### **Versatile**

- The Elcometer 319/2 can either be a hand held gauge or, using the docking unit, a stand-alone data logger
- Data can be downloaded to a PC and evaluated using ElcoMaster™ Software
- Manually or automatically stores data\*
- Inbuilt LED backup-torch



### **Accurate**

- Conforms to, and exceeds, ISO 8502-4
- Arrow indicators show temperature trends
- 3 AA batteries for up to 400 hours of use
- RH-probe has an integrated filter which protects it from airborne contaminations

\*Data can be stored manually or readings can be automatically stored by the Elcometer 319/2 to a user defined time period

## ElcoMaster™ Data Management Software

ElcoMaster™ makes it easy to collate and use the data recorded and is provided on a CD free with the Elcometer 319 Top Model and as an optional accessory for the Standard Model. It is the cornerstone of Elcometer's digital paperless data management systems and can be used with a range of gauges including the Elcometer 456 Digital Coating Thickness gauge, the Elcometer 224 Surface Profile Gauge, the Elcometer 319/2 Dewpoint meter and the Elcometer Ultrasonic Thickness gauges making it simple to produce complete, integrated reports. Whether the data is for analysis or to create professional reports for distribution to customers or colleagues, ElcoMaster™ can help. With inbuilt report templates and easy access to all data, images and other associated files, ElcoMaster™ makes managing data simple.

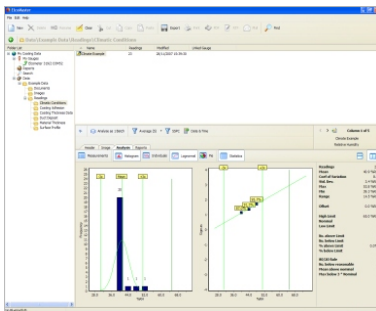

The software has been designed to be familiar and intuitive to any PC user. When the gauge is connected to the PC, individual readings can be sent directly to the software for real time analysis or simply 'drag and drop' a batch from the gauge to the software.

The associated job or inspection files, health and safety reports etc. can be stored within ElcoMaster™ - providing one programme that holds all the inspection information in one place.

Viewing data and producing standard reports is achievable in just a few clicks. Fully customised reports can be produced quickly by using the ElcoMaster™ Report Designer. Standard forms can be scanned into the system and the intelligent software has the ability to autofill.

In addition to the readings and charts, a digital photograph can be assigned to an individual batch of data, allowing the visual display of the inspection area in reports. Batches can be combined for immediate comparison of data from various areas of the job site.

ElcoMaster™ features:

- Create professional reports in seconds.
- Export reports to spreadsheets, text files or save as PDF or JPEG files.
- Copy and paste reports into other documents.
- Reports can be combined in order to clearly compare different batches.
- E-mail reports directly from ElcoMaster™
- Assign batch identification tags.
- Batches can be renamed to clearly identify the inspection batch.
- Wide range of standard reports include;
  - Individual measurements
  - Statistics
  - Histograms
  - Individual line or bar charts.
  - Log normal
  - Pie charts
- Fully customise reports using ElcoMaster™ Report Designer.
- Include company graphics and logos in every report.
- Combine batches to compare readings or link batches together from different gauges into one comprehensive inspection file.
- "Find" feature to quickly locate a specific file or batch.
- Integrated, Paperless Data Management has arrived!

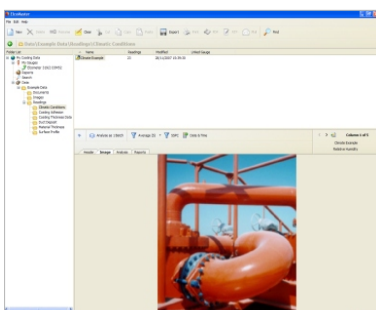
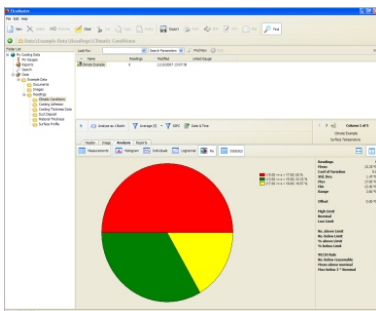

## Elcometer 319/2 Dewpoint Meter

### Technical Specification

Part Number	Description
<b>G319----S</b>	Elcometer 319/2 Standard Dewpoint Meter
<b>G319----T</b>	Elcometer 319/2 Top Dewpoint Meter, Docking Unit and ElcoMaster™
Air Temperature Range	-20°C to +80°C (-4°F to +176°F)
Air Temperature Accuracy	±0.5°C (±1°F)
Air Measurement Resolution	0.1°C (0.1°F)
Surface Temperature Range	-30°C to +60°C (-22°F to +140°F)
Surface Temperature Accuracy	±0.5°C (±1°F)
Surface Temperature Resolution	0.1°C (0.1°F)
External Surface Temperature Range	-30°C to +60°C (-22°F to +140°F)
External Surface Temperature Accuracy	±0.5°C (±1°F)
External Surface Temperature Resolution	0.1°C (0.1°F)
Relative Humidity Range	0 to 100%RH
Relative Humidity Accuracy at 23°C (73°F)	±3%RH
Relative Humidity Resolution	0.5%RH
Operating Temperature Range	-20°C to 60°C (-4°F to +140°F)
Memory - Manual Logging	6,000 records in a maximum of 8 batches
Memory - Interval Logging	12,000 records in a maximum of 8 batches
Limits	Limits adjustable for each parameter
Battery Type	3 x AA 1.5V batteries
Battery Life	400+ hours continuous (without backlight)
Dimensions	195 x 75 x 35mm (6.9 x 3 x 1.4")
Weight (including batteries)	300g (0.66lb)
Packing List	Standard Model: Elcometer 319/2 Dewpoint Meter, 3 x AA batteries, wrist strap, carry case, calibration certificate and operating instructions
	Top Model: Elcometer 319/2 Dewpoint Meter, 3 x AA batteries, wrist strap, docking unit, magnetic surface temperature probe, hexagonal wrench, USB cable and ElcoMaster™ Software, carry case, calibration certificate and operating instructions

Can be used in accordance with: (see Standards Explained inside Front Cover)

BS 7079-B4, ISO 8502-4, NSTM 009-32, US Navy PPI 63101-000

### Accessories

<b>T31920289</b>	Docking Unit - includes docking unit, hexagonal wrench, magnetic surface temperature probe, USB cable, ElcoMaster™ software (supplied as standard with Elcometer 319/2 Top Models)
<b>T31920162</b>	Magnetic Surface Temperature Probe
<b>T31920253</b>	Instrument Pouch
<b>T31920167</b>	Docking Unit to PC USB Cable

## Elcometer 116 Whirling & Sling Hygrometers

These instruments are designed to determine the dewpoint and relative humidity at any given time.

The Elcometer 116A Whirling Hygrometer is available in Celsius scale. A guide for Relative Humidity (RH) determination is supplied with each instrument and the dewpoint can accurately be obtained using the Elcometer 114 Dewpoint Calculator.

The Elcometer 116C Sling Hygrometer, shown as the black unit in the photograph, is a convenient, self contained instrument with an inbuilt slide rule for the calculation of %RH and dewpoint. It has spirit filled thermometers and is available in °C or °F scales.



- Manual operation, no power supply required
- Spirit filled thermometers

### Technical Specification

Part Number	Description
G116A---1	Elcometer 116A Whirling Hygrometer - Metric °C
G116C---1	Elcometer 116C Sling Hygrometer - Metric °C
G116C---2	Elcometer 116C Sling Hygrometer - Imperial °F
Dimensions	17 x 22mm (6.9 x 10")
Weight	300g (0.6lb)
Measuring range:	-5°C to 50°C (23°F to 122°F)
Packing list	Elcometer 116 Whirling Hygrometer or Elcometer 116 Sling Hygrometer, slide rule table and operating instructions

### Accessories

T1164441-	Elcometer 116A Spare Thermometer - °C	T1164442-	Elcometer 116A Spare Thermometer - °F
T1164478-	Elcometer 116C Spare Thermometer - °C	T1164479-	Elcometer 116C Spare Thermometer - °F
T1164487-	Elcometer 116A Wicks (Pack of 5)	T11600212	Elcometer 116A Replacement Slide Rule
T1164480-	Elcometer 116C Wicks (Pack of 4)		

## Elcometer 114 Dewpoint Calculator

This provides accurate values of Dewpoint and Relative Humidity (RH) from the wet and dry bulb temperatures measured by a Whirling or Sling Hygrometer.

The range of the Elcometer 114 is -10°C to 50°C (14°F to 122°F) and has an accuracy of ±1% with respect to standard tables.



### Technical Specification

Part Number	Description
G114----2	Elcometer 114 Dewpoint Calculator

### Elcometer 113 Magnetic Thermometers

The Elcometer 113 Magnetic Thermometer continuously indicates the surface temperature of steel and other magnetic material.

The thermometers are based on a bimetallic strip and therefore do not require batteries but do require time to adjust to the temperature.

Available in a number of scale ranges, the Elcometer 113 is also available as an economy version.



#### Technical Specification

Part Number	Description	Scale Range
G113----1	Elcometer 113 Magnetic Thermometer - Scale 1	-35°C to 55°C
G113----2	Elcometer 113 Magnetic Thermometer - Scale 2	0°C to 120°C
G113----3	Elcometer 113 Magnetic Thermometer - Scale 3	-20°C to 250°C
G113----4	Elcometer 113 Magnetic Thermometer - Imperial	0°F to 500°F
G113----1B	Elcometer 113 Economy Magnetic Thermometer - Scale 1	-35°C to 55°C
G113----2B	Elcometer 113 Economy Magnetic Thermometer - Scale 2	0°C to 120°C
Dimensions	15 x 19 mm (0.5 x 0.7")	
Weight	56g (0.12oz)	
Packing List	Elcometer 113 Magnetic Thermometer, protective pouch and operating instructions	

Customers who purchased the Elcometer 113 also purchased:



◀ Elcometer 112 Wet Film Combs, page 178 - 180

Elcometer 456 Digital Coating Thickness Gauge, page 177 - 188 ▶



## Elcometer 212 Digital Pocket Thermometer

Designed to cope with routine day to day use, the Elcometer 212 takes fast, accurate measurements. Incorporating auto-power On/Off functionality, by simply unfolding the probe, the instrument switches on.

- Large easy to read display
- Surface or Needle/Liquid probe options available
- Auto power On/Off
- °C or °F versions available



### Technical Specification

Part Number	Description	
G212----1	Digital Pocket Thermometer (°C) with Needle/Liquid Probe	
G212----3	Digital Pocket Thermometer (°F) with Needle/Liquid Probe	
G212----2	Digital Pocket Thermometer (°C) with Surface Probe	
G212----4	Digital Pocket Thermometer (°F) with Surface Probe	
	°C Models	°F Models
Temperature Range	-50°C to 300°C	-58°F to 572°F
Resolution	1°C	1°F
Accuracy	±1% of the reading ±1°C	±1% of the reading ±2°F
Ambient Temperature Range	0°C to 50°C	32°F to 122°F
Display	12.7mm Liquid Crystal Display	0.5" Liquid Crystal Display
Battery Type	12V MN21 Battery	12V MN21 Battery
Battery Life	Approximately 200 hours	Approximately 200 hours
Auto Switch Off Time	Approximately 5 minutes	Approximately 5 minutes
Case Dimensions	47 x 156 x 19mm	1.9 x 6.2 x 0.7"
Probe Length	110mm	4.3"
Weight	100g	3.5oz
Packing List	Elcometer 212 Digital Pocket Thermometer with battery fitted and operating instructions	

## Elcometer 213/2 Digital Waterproof Thermometer

The Elcometer 213/2 Digital waterproof thermometer offers the latest microprocessor technology, superior durability and is designed for reliability and ease of use.

### Features:

- Rubber bumper seals for impact resistance
- Waterproof case (IP66 & IP67 protection)
- Extruded aluminium case for superior durability
- °C/°F switchable
- Easy to read LCD display



Probes are available to purchase separately.

### Technical Specification

**C.A** certificate available

Part Number	Description
<b>G213----</b> 2	Elcometer 213/2 Digital Thermometer*
Operating Range <sup>†</sup>	-49°C to +1372°C (-56°F to 2500°F)
Accuracy	±1% of the reading ±1 digit
Resolution	0.1°C (0.1°F) up to 299.9°C (572°F), 1°C (1°F) above 299.9°C (599.9°F)
Battery Life	5,000 hours
Power Supply	1 x MN1604/PP3 (9V) battery
Dimensions	35 x 60 x 115mm (1.4 x 2.4 x 4.5")
Weight	194g (0.42lb)
Packing List	Elcometer 213/2 Digital Waterproof Thermometer, fitted battery, carry case and operating instructions

\*Probes are not supplied as standard with the Elcometer 213/2; please select from the list below

<sup>†</sup> Operating range is dependent on probe used

### Accessories

<b>T21311728</b>	Magnetic Surface Probe, 13mm Diameter (0.51")	Range: -50°C to 150°C (-58°F to 302°F)
<b>T2136069-</b>	Surface Probe, 130 x 4.2mm Diameter (5.11 x 0.17")	Range: -50°C to 600°C (-58°F to 1112°F)
<b>T2136390-</b>	Liquid Probe, 130 x 3mm Diameter (5.11 x 0.12")	Range: -50°C to 850°C (-58°F to 1562°F)
<b>T2136391-</b>	Needle Probe, 130 x 3mm Diameter (5.11 x 0.12")	Range: -50°C to 400°C (-58°F to 752°F)

Other probes available on request. Contact Elcometer for further information.



T21311728



T2136390-



T2136069-



T2136391-

## Elcometer 213 Digital Thermometer

The Elcometer 213 Digital Thermometer allows quick and easy measurement for a wide range of applications using the K-type thermocouple and gives readings in °C.

- Measures temperature in the range of -50°C to 850°C, (the maximum temperature is dependent on probe type), with high accuracy and resolution.
- Quick temperature response.



Probes are available to purchase separately.

### Technical Specification

**C,A** certificate available

Part Number	Description
<b>G213----</b> 1	Elcometer 213 Digital Thermometer*
Operating Range <sup>†</sup>	-50°C to 1370°C
Accuracy	±1% of the reading ±1 digit
Resolution	1°C across the range
Time Constant	Approximately 1 second
Ambient Temperature	0°C to 50°C
Instrument Display Range	-50°C to 850°C
Power Supply	1 x 6F22 (9V) Battery
Dimensions	36 x 80 x 147mm (1.4 x 3.2 x 5.8")
Weight	210g (0.46lb)
Packing List	Elcometer 213 Digital Thermometer, battery, carry case and operating instructions

\*Probes are not supplied as standard with the Elcometer 213; please select from the list below

<sup>†</sup>Operating range is dependent on probe used

### Accessories

<b>T21311728</b>	Magnetic Surface Probe, 13mm Diameter (0.51")	Range: -50°C to 150°C (-58°F to 302°F)
<b>T2136069-</b>	Surface Probe, 130 x 4.2mm Diameter (5.11 x 0.17")	Range: -50°C to 600°C (-58°F to 1112°F)
<b>T2136390-</b>	Liquid Probe, 130 x 3mm Diameter (5.11 x 0.12")	Range: -50°C to 850°C (-58°F to 1562°F)
<b>T2136391-</b>	Needle Probe, 130 x 3mm Diameter (5.11 x 0.12")	Range: -50°C to 400°C (-58°F to 752°F)

Other probes available on request. Contact Elcometer for further information.



T21311728



T2136390-



T2136069-



T2136391-



## Elcometer 214L Infrared Digital Thermometer

This Infrared Laser Thermometer has a wide temperature range of -32°C to 420°C (-25.6°F to 788°F) and an optical resolution of 20:1 allowing accurate, non-contact surface temperature measurements to be taken.

The Elcometer 214L can measure objects as small as 13mm (0.51"): simply aim and press the trigger to display the temperature measurement.

### Features:

- Precision glass optics for accurate, non-contact temperature measurement
- Temperature measurement from -32°C to 420°C (-25.6°F to 788°F)
- Fast, 0.3 second, scanning of cold and hot spots
- Laser sighting with narrow beam for accurate readings
- Exact readings on objects as small as 13mm (0.51")



### Technical Specification

Part Number	Description
G214L----2	Elcometer 214L IR Digital Thermometer (Laser)
Temperature Range	-32°C to 420°C (-25.6°F to 788°F)
Resolution	0.2°C (0.5°F)
Accuracy	±1% of reading or ±1°C (±1.8°F): 0° to 420°C (-25.6°F to 788°F) ±1% of reading or ±0.07°C (±0.1°F): 0°C to -32°C (32°F to -25.6°F)
Optical Resolution	20:1, 13mm (0.51") spot size
Emissivity	Fixed at 0.95
Response Time	300ms
Battery Type	9V MN1604/PP3 alkaline battery
Dimensions	190 x 38 x 45mm (7.5 x 1.5 x 1.8")
Weight	150g (5.3oz) without battery
Packing List	Elcometer 214L Digital Thermometer (Laser), battery and operating instructions

Customers who purchased the Elcometer 214L also purchased:



- ◀ Elcometer 215 Oven Temperature Data Logger, page 168 - 172
- Elcometer 107 Cross Hatch Adhesion Tester, page 217 ▶



## Elcometer 214 Infrared Digital Thermometer

The Elcometer 214 Infrared Digital Thermometer is a hand held, battery operated instrument. It safely and accurately measures surface temperature of non reflective materials using infrared technology which allows fast, non-contact temperature measurement, thereby avoiding surface contamination.

The Elcometer 214 Infrared Digital Thermometer has a spot ratio of 3:1 with a 25mm (1") minimum target diameter. The closer you get to the object under inspection, the smaller the spot size and hence the more precise the targeting of the measurement.



### Technical Specification

Part Number	Description
G214----1	Elcometer 214 IR Digital Thermometer
Temperature Range	-18°C to 315°C (0°F to 600°F)
Resolution	1°C (°1F)
Accuracy	±2% of reading or ±2°C (±3°F)
Optical Resolution	3:1, 25mm (1") spot size
Emissivity	Fixed at 0.95
Response Time	Approximately 1 second
Battery Type	9V MN1604/PP3 alkaline battery
Dimensions	184 x 43 x 19mm (7.3 x 1.7 x 0.75")
Weight	77g (2.72oz) without battery
Packing List	Elcometer 214 IR Digital Thermometer, battery and operating instructions

Customers who purchased the Elcometer 214 also purchased:



◀ Elcometer 456 Coating Thickness Gauge, page 188 - 193

Elcometer 406L Gloss Meter page 109 ▶



## Elcometer 6700 Electronic Thermo-Hygrograph

The Elcometer 6700 is a portable laboratory instrument which records the ambient temperature from  $-15^{\circ}\text{C}$  to  $40^{\circ}\text{C}$  ( $5^{\circ}\text{F}$  to  $104^{\circ}\text{F}$ ) and relative humidity (0 to 100% RH) using the hair hygrometer principle.

- Indication recorded on a paper diagram
- Push-button selection of five time periods: 1, 7, 31, 62 and 93 days
- Quartz movement
- Battery operated



### Technical Specification

Part Number	Description
<b>K0006700M001</b>	Electronic Thermo-Hygrograph
Dimensions	325 x 145 x 282mm (12.7 x 5.7 x 11")
Weight	Approximately 3kg (6.6lb)
Packing List	Electronic Thermo-Hygrograph, reading chart and operating instructions

### Accessories

<b>KT006700N001</b>	1 Day Reading Chart Diagrams - 400 Sheets
<b>KT006700N003</b>	7 Day Reading Chart Diagrams - 55 Sheets
<b>KT006700N005</b>	31 Day Reading Chart Diagrams - 15 Sheets
<b>KT006700P001</b>	Spare Pen for Thermo Hygrograph

Customers who purchased the Elcometer 6700 also purchased:



◀ Elcometer 1542 Cross Hatch Adhesion Cutter, page 218

Elcometer 407 Gloss Meter, page 109



## Elcometer 215 Oven Data Logger

The Elcometer 215 is an easy to use oven data logger, used to measure and record the oven temperature profile. By logging both the product's surface and air temperatures in a cure oven, the Elcometer 215 records the temperature profile. The temperature of the sample must be cooler at the thinner section and hotter at the thicker section. If the temperature was uniform, the coating on the thin substrate would burn, while the coating on the thicker section might not have time to cure. The Elcometer 215 probes have been specifically designed to produce accurate readings and feature:

- Perfect probe to surface contact
- Low mass and optimised shape to avoid influence on temperature behaviour
- Extremely strong, highly flexible and easy to clean Teflon® coated cables

Measure temperature horizontally and vertically as it is passed through the cure process

Specifically designed for powder coating cure ovens, wet coating ovens, batch ovens and conveyor ovens

Large menu-driven display for easy operation

Optional add-on to convert the 6 channel data logger into a 12-channel system

Ideal in situations where powder coated thickness is inconsistent

Generate tailor-made information about the coating process using five different data-evaluation methods

Menus in five languages: English, French, German, Italian and Spanish

Display the results of every stored batch, including Cure-index



## Flexible evaluation of data

- *Quick display* - the logger display shows maximum temperature and Cure-index figure, percentage and pass/fail sign, or graphic representation for each probe
- *Wireless print* - the optional portable infrared printer can produce brief reports which include: Cure-index, maximum temperature and graphs for immediate information review
- *Logger to printer* - a complete, full-colour report can be printed directly to any PCL3 compatible printer using the optional link. No computer required!
- *Extensive analysis* - comprehensive calculations and fully customisable reports are easily produced as each system is supplied with the powerful "Ideal Finish" data analysis software. See page 168 for details.
- *Expandable* - the number of channels available can be expanded from the basic 6 to 12 channels with the addition of an optional expansion unit.

## Simple 3-step operation for basic features:

1. Connect the probes to the product and switch on
2. Place the logger in the box and send it through the oven
3. Read the results from the display or send them to a printer or PC

## A wide range of temperature probes

- **Magnetic Surface probe** - this probe is fitted with an ultra strong magnet, but still has a very low mass and size. The actual sensor is thermally isolated from the magnet so as not to affect the part's temperature. This sensor is suited for use on round parts such as tubes
- **Clamp surface probe** - small, elegant surface probe for any type of material. The silver tipped sensor is thermally isolated from the clamp by a ceramic isolator
- **Ring surface probe** - a universal probe with an aluminium ring at the tip for fast response
- **Air temperature probe** - available with either a clamp or magnet
- **Probe cable** - most of our standard probes are equipped with our special probe cable which is easy to clean due to the Teflon outer shield

Each logger comes with a set of metal probe-tags to help match each probe to its assigned channel

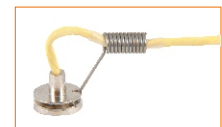

Magnetic surface



Clamp surface probe



Ring surface probe



Clamp air probe



Magnetic air probe



Wire probe

Start and stop logging at a pre-set temperature

Extended memory stores 10 batches of 25,000 measurements in each

Variable measurement interval, date, time, °C / °F

## Elcometer 215 Ideal Finish Software

The Elcometer 215 Oven-Logger is supplied with Ideal Finish software which has been designed specifically for the powder cure and paint cure processes.

The graphical user interface is based on standard Windows terminology and, as a result, making it highly user friendly.

Features include:

- The Elcometer 15 will inform you immediately after the process whether the paint is sufficiently cured or if the process has failed
- Important information, such as the thermostat settings, track speed, type of paint, client data etc. can be added to print a complete quality report
- The “SMART” option in the Ideal Finish Software allows the user to insert the cure specifications of the powder supplier
- Connects to an IR printer for immediate results
- Saves on re-work costs
- Improves quality

A User Settings Wizard is incorporated, making it easy for the user to add the required fields, such as sample rate, paint type, temperature units, cure specification, probe names, date and time. It is easy to create your own paint library, complete with cure specifications.

The Download Logger Wizard makes downloading data as easy as clicking a button.

The Elcometer 215 Oven Logger is connected to a PC by a cable direct to a communications port on the PC. The Language, Temperature and Distance units can all be individually configured.

There is also an outgoing Mail configuration, enabling any report to be quickly emailed. The reports produced can be personalised to show, the name, address, logo and website of your company automatically.

Advanced calculation functions and enhanced process files make it possible to evaluate every part of the cure process and quickly judge the oven performance, allowing adjustments to the process, such as line speed or oven temperature, to be made.

The data batches can be viewed in various formats and analysed. The default setting is a 2D graph which can be changed to suit almost any application including a 3D surface graph which graphically displays the performance of the oven as a whole or in sections.

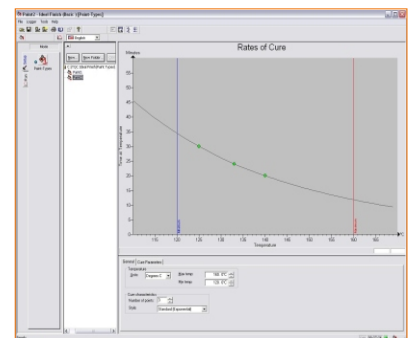
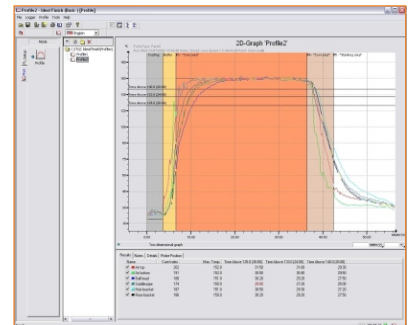

Ideal Finish, with its two user levels, “Basic” and “Advanced”, is one of the most user friendly and advanced temperature monitoring software packages.

The Basic Mode features:

- ability to download data from the logger
- ability to create new paint types and profiles
- draw curing graphs which plot temperature against time
- draw graphs which provide details to set the optimum cure temperature
- calculates the cure index

The Advanced Mode provides users with a variety of enhanced tools including a tool for customising the reports generated so that the style can be refined to meet individual requirements, enhanced data tabs, allowing data to be viewed in columns, modification of probe properties and the use of reference curves to compare previous with current measurements.

The Elcometer 215 Ideal Finish software provides all the information necessary to make the right decisions to optimise the production line.

## Technical Specification

**C** certificate available

Part Number	Description
<b>G215----1</b>	Elcometer 215 Oven Data Logger Kit
Accuracy	±1.0°C (0°C - 300°C), ±3°C (>300°C) ±2.0°F (32°F - 572°F), ±5°F (>572°F)
Resolution	0.1°C (0.2°F)
Temperature Range	-50°C to 1200°C (-58°F to 2190°F)
Operating Temperature	0°C to 60°C (32°F to 140°F)
Probe Type	K type Thermocouple
Probe Range	-50°C to 300°C (-58°F to 572°F)
Display	LCD Display 126 x 64 pixels
Memory	254,000 readings
Measuring Intervals	2 seconds to 1 hour, user selectable
Power Supply	3 x AA batteries
Channels	6 (or 12 with expansion unit)
Printing Output	Infrared (HPSIR) or direct (PCL3)
Data Output	RS 232 at 115,200 baud
Dimensions	105 x 86 x 30mm (4.1 x 3.4 x 1.2")
Weight	300g (10.6oz)
Packing List	Elcometer 215 Oven Data Logger, Ideal Finish software, 3 x AA batteries, data cable, insulation box, heat sink, wheeled carry case and operating instructions

For the full range of Probes and Accessories, see page 172



## Accessories

T21513852	1.5m Clamp Surface Probe (300°C/572°F)
T21513765	1.5m Clamp Surface Probe (480°C/896°F)
T21518776	1.5m Clamp IR Surface Probe (1000°/1832°F)
T21513855	3m Clamp Surface Probe (300°C/572°F)
T21518769	3m Clamp Surface Probe (480°C/896°F)
T21518760	5m Clamp Surface Probe (300°C/572°F)
T21513853	1.5m Clamp Air Probe (300°C/572°F)
T21513768	1.5m Clamp Air Probe (480°C/896°F)
T21518757	3m Clamp Air Probe (300°C/572°F)
T21518772	3m Clamp Air Probe (480°C/896°F)
T21518763	5m Clamp Air Probe (300°C/572°F)
T21518854	1.5m Magnetic Surface Probe (300°C/572°F)
T21518766	1.5m Magnetic Surface Probe (480°C/896°F)
T21518777	1.5m Magnetic IR Surface Probe (1000°/1832°F)
T21518856	3m Magnetic Surface Probe (300°C/572°F)
T21518770	3m Magnetic Surface Probe (480°C/896°F)
T21518761	5m Magnetic Surface Probe (300°C/572°F)
T21518755	1.5m Magnetic Air Probe (300°C/572°F)
T21518758	3m Magnetic Air Probe (300°C/572°F)
T21518555	1.5m Ring Surface Probe (300°C/572°F)
T21518767	1.5m Ring Surface Probe (480°C/896°F)
T21518557	3m Ring Surface Probe (300°C/572°F)
T21518771	3m Ring Surface Probe (480°C/896°F)
T21518762	5m Ring Surface Probe (300°C/572°F)
T21518756	1.5m Wire Air Probe (300°C/572°F)
T21518759	3m Wire Probe (300°C/572°F)
T21518764	5m Wire Probe (300°C/572°F)
T21518773	1.5 ring Iconel Bendable Probe (1000°/1832°F)
T21518774	3m ring Iconel Bendable Probe (1000°/1832°F)
T21518775	5m ring Iconel Bendable Probe (1000°/1832°F)
T21518778	1.5m Ball IR Air Probe (1000°/1832°F)
T21518566	Logger to PC Interface Cable
T99918561	PCL3 Printer-Link Converter with Cable
X99913877	IR Printer
T21513859	Steel box, Lid and Gasket 250 x 200 x 140mm (9.8 x 7.9 x 5.5")
T21513862	Gasket - small 255 x 205 mm (10 x 8")
T21513861	Heat Absorber
T21513863	Ideal Finish Software
T21518780	Additional Data Logger
T21518559	6 Channel Expansion Unit
T21518560	6 Channel Expansion Unit Heat Absorber

*Additional probe lengths, probe temperature ranges and probe types are available.  
Please contact Elcometer for further information*



Clamp surface probe



Clamp air probe



Magnetic surface



Magnetic air probe



Ring surface probe



Wire probe



## Elcometer 118/2 Surface Moisture Meter

The Elcometer 118/2 Surface Moisture Meter is a hand held instrument which instantly and accurately measures moisture content in wood by-products, wood and building materials such as roofing, insulation, plaster and brick.

The Elcometer 118/2 features:

- Inbuilt electrodes allowing the gauge to be used immediately, saving time
- Quick, accurate results using conductivity measurement method
- Lightweight aluminum moisture meter which can easily be carried on site

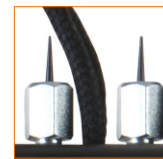

### Technical Specification

**T** certificate available

Part Number	Description
G118----2	Elcometer 118/2 Surface Moisture Meter
Measuring Range	Up to 42% wood moisture content <sup>1</sup>
Accuracy	±1.5%
Dimensions	190 x 75 x 30mm (7.4 x 3 x 1")
Weight	250g (8.8oz)
Battery Supply	9V alkaline battery (6F22 [PP3] type)
Battery Life	72 hours continuous
Packing List	Elcometer 118/2 Moisture Meter, 9V PP3 battery, fabric carry case, calibration certificate and operating instructions

<sup>1</sup> Readings above 27% (normal value of the fibre saturation point) are indicative only

### Accessories

T11820064	Probe Pins (Pack of 10)
T11820063	Calibration Plugs (Set of 3)

## Elcometer 7400 Compact Moisture Meter

The natural feel of the Elcometer 7400 makes it easy to use, allowing the pins on the end of the instrument to be pressed into the material to be measured.

The thin pins allow easy measurement of the moisture content of sawn timber, chipboard and fibreboard materials up to a maximum thickness of 25mm (0.98") as well as normal gypsum and mixed plaster.

- Completely automatic instrument setting
- No separate electrodes or leads required
- Handy, quick and pocket-sized for fast measurements
- Correction for two groups of wood species
- Measurement of plaster moisture content with a direct readout in percentage of dry weight
- Uses the conductivity measurement method

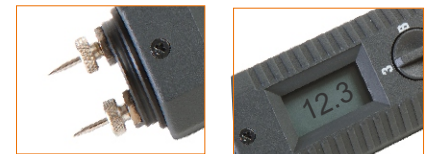

### Technical Specification

Part Number	Description
<b>K0007400M018</b>	Elcometer 7400 Compact Moisture Meter
Measuring Range	Large 3-digit LCD readout Wood 5 to 20% moisture content for wood with correction for two groups of wood species. Plaster 0.3 to 3.5% moisture content for plaster
Substrate Type	Sawn timber, chipboard, fibreboard, gypsum, plaster
Dimensions	190 x 75 x 30mm (7.4 x 3.0 x 1.0")
Weight	180g (6.35oz)
Power Supply	9V dry cell or rechargeable battery (6F22 (PP3) type)
Packing List	Elcometer 7400 Compact Moisture Meter, 9V PP3 battery, spare pins, protective cap and operating instructions

## Elcometer 7400 Compact “A” Moisture Meter

The measuring principle of the Compact “A” is based on the dielectric constant, or high frequency, method.

The meter is placed on the material to be tested and the moisture content can be read immediately. No need to drive pins into the wood.

- Handy and pinless for fast measurements
- No separate measuring electrodes or cables required
- Fully automatic adjustment of the indicator
- Setting device for automatic correction of the readings depending on the species of wood



### Technical Specification

Part Number	Description
K0007400M021	Elcometer 7400 Compact 'A' Moisture Meter
Measuring Range	Digital LCD readout, 5 to 45% moisture content and wood species selector switch (10 settings) Suitable for timber up to 40mm (1.57") thick
Substrate Type	Sawn timber, chipboard, fibreboard, gypsum, plaster
Dimensions	170 x 35 x 35mm (6.7 x 1.38 x 1.38")
Weight	130g (4.6oz)
Power Supply	9V dry cell or rechargeable battery (6F22 (PP3) type)
Packing List	Elcometer 7400 Compact "A" Moisture Meter, 9V PP3 battery and operating instructions

## Elcometer 7400 Compact “B” Moisture Meter

The Elcometer 7400 Compact “B” is an electronic moisture indicator using a patented technique based on the dielectric constant/high frequency method. It has a LCD display with universally applicable ball sensor for non-destructive location of moisture in all kinds of building materials and is also suitable for assessment of moisture distribution in walls, floors and ceilings.

- Handy rapid-action moisture indicator for fast response
- No separate measuring electrodes or cables required
- Ideal pre-tester for use with all moisture analysers using the carbide method
- Fully automatic adjustment of the indicator



### Technical Specification

Part Number	Description
K0007400M023	Elcometer 7400 Compact 'B' Moisture Meter
Measuring Range	Wood 5 - 45%, 0 to 100 digits
Dimensions	200 x 35 x 35mm (7.87 x 1.38 x 1.38")
Weight	190g (6.7oz)
Power Supply	9V dry cell or rechargeable battery (6F22 (PP3) type)
Packing List	Elcometer 7400 Compact "B" Moisture Meter, 9V PP3 battery and operating instructions

## Elcometer 7410 Concrete Moisture Meter

The Elcometer 7410 is an accurate and easy to use non-invasive instrument for non-destructive measurement of moisture content of concrete.

The electrodes transmit parallel low frequency signals, calibrated to give average moisture content by comparing the change in impedance between damp and acceptably dry concrete.

- Calibrated ready for use on concrete
- Instant readings on a clear, easy to read scale
- Fully portable, battery operated and non-destructive



### Technical Specification

Part Number	Description
<b>K0007410M001</b>	Elcometer 7410 Concrete Moisture Meter
Measuring Range	Concrete 0 - 6%, Floor screed 0-10%
Substrate Type	Concrete, gypsum floor screed
Measurement Depth	125mm (5")
Dimensions	155 x 85 x 43mm (6.1 x 3.3 x 1.7")
Weight	298g (10.5oz)
Power Supply	9V PP3 battery (6F22 (PP3) type)
Packing List	Elcometer 7410 Concrete Moisture Meter, battery, carry case and operating instructions

## Elcometer 7420 Digital Moisture Meter

Handy and easy to use, the Elcometer 7420 does not use pins and therefore does not damage the substrate under test.

The gauge is placed on to the material to be evaluated and quickly indicates the degree of moisture in concrete, fibreglass or wood, to a depth of 300mm (1.2")

- Uses high frequency methods
- Digital display with moisture/dry comparison scale
- No damage to the surface



### Technical Specification

Part Number	Description
<b>K0007420M001</b>	Elcometer 7420 Digital Moisture Meter
Dimensions	150 x 80 x 30mm (6 x 3.1 x 1.4")
Weight	298g (10.5oz)
Power Supply	9V PP3 battery (6F22 [PP3] type)
Packing List	Elcometer 7420 Digital Moisture Meter, carry case, battery and operating instructions

## Wet Film and Powder Thickness

Whether you are applying a liquid or powder coating, by measuring the uncured film thickness, it is possible to determine the eventual dry film thickness.

Applying too much coating not only wastes time and materials, it can also affect the performance and finish of the product. Too much wet film can cause the coating to crack as it cures; too little coating increases the risk that the substrate will not be sufficiently protected, leading to rust spots.

In the powder coating industry, ensuring the end product has the correct levels of adhesion and appearance is dependent on the thickness of the powder prior to the curing process. Too much powder can lead to poor adhesion, too little can lead to a discolouration and loss in gloss of the coating.

The three methods for measuring wet film thickness are:

- Wet Film Combs
- Pfund Thickness Gauges
- Wet Film Wheels

In each case, the thickness of the coating is measured and the dry film thickness can be estimated using the coating's *solid : wet ratio*.

Whereas wet film measurement is non-destructive, the measurement of powder thickness using any form of contact with the uncured coating, causes the powder to compress, altering its thickness. The revolutionary Elcometer 550 determines the cured powder thickness by the non-contact measurement of the uncured coating, making it an ideal solution to powder coating measurement on the production line.

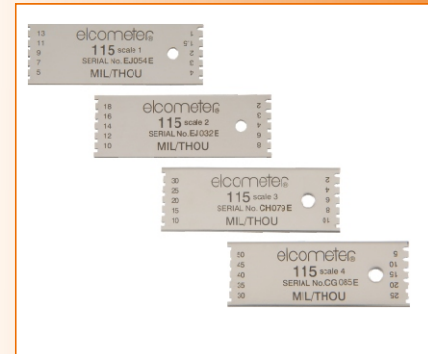

### Using a wet film comb



Place a comb perpendicular to and touching the substrate. Hold the comb in position and wait a few seconds until the teeth are wet. Remove the comb from the film.

The wet film thickness lies between the biggest value 'coated' or 'wet' tooth and the smallest value 'uncoated' or 'dry' tooth.

### Using a wet film wheel

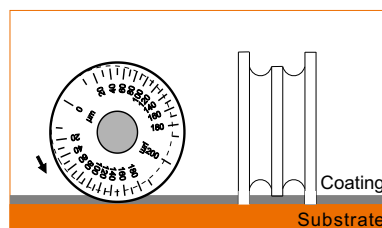

Roll the wheel through a wet coating, the centre wheel eventually touches the film. This point on the scale indicates the thickness.

When the volume to solids ratio of the coating is known, generally found on a product data sheet, the wet film thickness can be used to predict the dry film thickness.

## Elcometer 115 Wet Film Combs

These reusable precision stainless steel combs are made to be long lasting and are supplied with Metric and Imperial values on the same comb.

Four separate thickness ranges are available up to a maximum of 1270µm (50mils) and manufactured to an accuracy of ±5% or 2.5µm (0.01mil), whichever is the greater.

Each comb has 10 measurement steps (teeth).

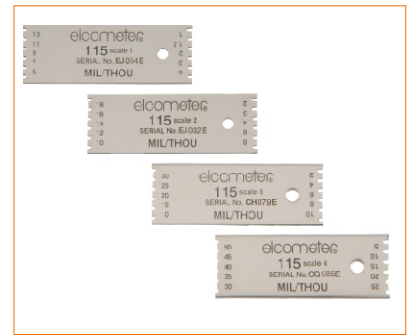

### Technical Specification

**CA** certificate available

Part Number	Description	Range	
<b>B11529451</b>	Elcometer 115/1 Wet Film Comb	25 - 330µm	1 - 13mils
<b>B11529452</b>	Elcometer 115/2 Wet Film Comb	51 - 457µm	2 - 18mils
<b>B11529453</b>	Elcometer 115/3 Wet Film Comb	51 - 762µm	2 - 30mils
<b>B11529454</b>	Elcometer 115/4 Wet Film Comb	127 - 1270µm	5 - 50mils
<b>B11529459W</b>	Elcometer 115/W Set of 4 Wet Film Combs*		
Dimensions	73 x 25 x 2mm (2.87 x 1 x 0.08")		
Weight	21g (0.74oz) per Comb		
Packing List	Wet Film Comb, storage case and operating instructions		
<i>Can be used in accordance with: (see Standards Explained inside Front Cover)</i>			
<b>ASTM D 4414-A, AS/NZS 1580.107.3, BS 3900-C5-7B, ISO 2808-1A, NFT 30-125</b>			

\* Please specify the ranges required when ordering.

## Elcometer 3238 Long Edge Wet Film Combs

These stainless steel combs are wire eroded to provide an accuracy of ±2.5µm (0.01mil) and are supplied with either Metric or Imperial measurements.

Each comb has 24 measurement stages (teeth) providing a more accurate wet film thickness value.

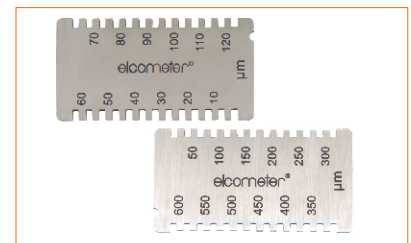

### Technical Specification

**CA** certificate available

Part Number			Metric		Imperial	
Metric	Imperial	Model	Range	Steps	Range	Steps
<b>K0003238M001</b>	<b>K0US3238M001</b>	Elcometer 3238/1	5 - 120µm	5µm	0.5 - 6mils	0.5mil
<b>K0003238M002</b>	<b>K0US3238M002</b>	Elcometer 3238/2	25 - 600µm	25µm	1 - 24mils	2mils
<b>K0003238M003</b>	<b>K0US3238M003</b>	Elcometer 3238/3	50 - 1200µm	50µm	2 - 48mils	4mils
<b>K0003238M004</b>	<b>K0US3238M004</b>	Elcometer 3238/4 Set of 3 Wet Film Combs*				
Dimensions	60 x 30 x 2mm (2.36 x 1.18 x 0.08")					
Weight	27g (0.95oz) per comb					
Packing List	Wet Film Comb, storage case and operating instructions					
<i>Can be used in accordance with: (see Standards Explained inside Front Cover)</i>						
<b>ASTM D 4414-A, AS/NZS 1580.107.3, BS 3900-C5-7B, ISO 2808-1A, NFT 30-125</b>						

\*Set comprises of one of each scale 1, 2 and 3

## Elcometer 112 & 3236 Hexagonal Wet Film Combs

These hexagonal precision formed stainless steel wet film combs are long lasting and reusable and are supplied in a range of thicknesses measuring up to 3000µm (120mils).

These six sided combs vary in size, giving either 24 or 36 measurement steps, depending on the comb, providing increased accuracy.



### Technical Specification

**CA** certificate available

Part Number	Model	Range	Values
K0003236M001	Elcometer 3236/1	20 - 370µm	20, 30, 40, 50, 60, 70, 80, 90, 100, 110, 120, 130, 150, 170, 190, 210, 230, 250, 270, 290, 310, 330, 350, 370µm
K0003236M002	Elcometer 3236/2	25 - 2000µm	25, 50, 75, 100, 125, 150, 175, 200, 225, 250, 275, 300, 350, 400, 450, 500, 550, 600, 650, 700, 750, 800, 850, 900, 950, 1000, 1100, 1200, 1300, 1400, 1500, 1600, 1700, 1800, 1900, 2000µm
B112----1	Elcometer 112	25 - 3000µm	25, 50, 75, 100, 125, 150, 175, 200, 225, 250, 275, 300, 350, 400, 450, 500, 550, 600, 650, 700, 750, 800, 850, 900, 1000, 1100, 1200, 1400, 1600, 1800, 2000, 2200, 2400, 2600, 2800, 3000µm
B112----2	Elcometer 112	1 - 120mils	1, 2, 3, 4, 5, 6, 7, 8, 9, 10, 11, 12, 14, 16, 18, 20, 22, 24, 26, 28, 30, 32, 34, 36, 38, 40, 45, 50, 55, 60, 70, 80, 90, 100, 110, 120mils
Dimensions and Weight	Elcometer 3236/1		53 x 50 x 2mm (2.09 x 1.97 x 0.08"), 19g (0.67oz)
	Elcometer 3236/2		77 x 90 x 2mm (2.95 x 3.54 x 0.08"), 43g (1.52oz)
	Elcometer 112		75 x 65 x 2mm (2.95 x 2.54 x 0.08"), 41g (1.4oz)
Packing List	Wet Film Comb, storage case and operating instructions		

Can be used in accordance with: (see Standards Explained inside Front Cover)

ASTM D 4414-A, AS/NZS 1580.107.3, BS 3900-C5-7B, ISO 2808-1A, NFT 30-125

## Elcometer 112AL Punched Aluminium Wet Film Combs

These punched aluminium combs offer the user a low cost method of measuring the wet film thickness.

The Elcometer 112AL, being punched from aluminium, is not as accurate as precision formed, stainless steel wet film combs and has a shorter lifespan.

Supplied in a pack of 10 combs, they have Metric units (25 - 3000µm) on one side and Imperial values (1 - 118mils) on the other.



### Technical Specification

Part Number	Description
B112AL12473-3	Elcometer 112AL Aluminium Wet Film Comb* (Pack of 10)
Dimensions	75 x 65 x 1mm (2.95 x 2.56 x 0.04")
Weight	90g (3.17oz)
Packing List	Elcometer 112AL (Pack of 10) and operating instructions

Can be used in accordance with: (see Standards Explained inside Front Cover)

ASTM D 4414-A, AS/NZS 1580.107.3, BS 3900-C5-7B, ISO 2808-1A, NFT 30-125

\* The Elcometer 112AL can be customised with your logo. Please contact Elcometer for further details.

## Elcometer 154 Plastic Wet Film Combs

The Elcometer 154 Wet Film Combs are made from ABS plastic and are designed to be used once and kept as a record of wet film thickness measurement for quality assurance or customer requirements.

Metric and Imperial values are on the same comb, 50 to 800µm on one side, 2 to 32mils on the other.

Supplied in a pack containing 500 combs. Each comb has 16 measurement steps.



### Technical Specification

Part Number	Description
<b>B154----1</b>	Elcometer 154 Plastic Wet Film Combs (Pack of 500)
Dimensions	40 x 40mm (1.57 x 1.57")
Weight	900g (2lb)
Packing List	Elcometer 154 Wet Film Combs (Pack of 500) and operating instructions

*Can be used in accordance with: (see Standards Explained inside Front Cover)*  
**AS/NZS 1580.107.3, BS 3900-C5-7B, ISO 2808-1A, NFT 30-125**

## Elcometer 3233 Pfund Thickness Gauge

This instrument consists of two concentric cylinders, one sliding inside the other. A spherical glass lens, which has engraved measurements, is fitted to the end of the central cylinder and when pressed into the wet film, leaves a circular trace.

The diameter of the mark on the lens is measured and, using the supplied conversion table, the thickness of the coating can be easily assessed.

- Ideal for measuring the thickness of wet translucent products such as varnish, oils etc
- Measurement range of 2.25 - 360µm (0.09 - 14.17mils)



### Technical Specification

Part Number	Description
<b>K0003233M001</b>	Elcometer 3233 Aluminium Pfund Thickness Gauge
<b>K0003233M002</b>	Elcometer 3233 Stainless Steel Pfund Thickness Gauge
Dimensions	60 x 80mm (2.36 x 3.15")
Weight	113g (4oz)
Packing List	Pfund Thickness Gauge, stainless steel rule, conversion table, storage case and operating instructions

*Can be used in accordance with: (see Standards Explained inside Front Cover)*

**ASTM D 1212-B, NFT 30-125**



## Elcometer 3230 Wet Film Wheels

The Elcometer 3230 Wet Film Wheel is a high precision, accurate and easy to use instrument which consists of a set of three wheels. The central wheel is of a smaller diameter and is eccentric relative to the two outer wheels. By rolling the gauge through a wet coating, the centre wheel eventually touches the film. This point on the scale indicates the thickness.

A convenient mounting handle for the wheel is available in two lengths; 15cm (6") & 50cm (19"); please order separately.

When the volume to solids ratio of the coating is known (generally found on the product data sheet supplied by the manufacturer), the wet film thickness can be used to predict the dry film thickness.

Several measurement ranges between 0 to 25µm and 0 to 3000µm (0 to 1mil and 0 to 40mils) are available.

- Continuous scale produces ±5% measurement accuracy
- Suitable for flat and curved surfaces

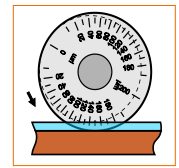

### Technical Specification

**C.A** certificate available

Part Number	Metric		Part Number	Imperial	
	Scale Range	Graduations		Scale Range	Graduations
K0003230M001	0 - 25µm	1.25µm	K0US3230M001	0 - 1mil	0.05mil
K0003230M016	0 - 40µm	2.0µm	-	-	-
K0003230M002	0 - 50µm	2.5µm	K0US3230M002	0 - 2mils	0.10mil
K0003230M003	0 - 100µm	5.0µm	K0US3230M003	0 - 4mils	0.20mil
K0003230M004	0 - 150µm	7.5µm	K0US3230M004	0 - 6mils	0.25mil
K0003230M005	0 - 200µm	10.0µm	-	-	-
K0003230M006	0 - 250µm	12.5µm	-	-	-
K0003230M007	0 - 300µm	15.0µm	K0US3230M005	0 - 12mils	0.50mil
K0003230M008	0 - 400µm	20.0µm	-	-	-
K0003230M009	0 - 500µm	25.0µm	K0US3230M006	0 - 20mils	1.0mil
K0003230M010	0 - 1000µm	50.0µm	K0US3230M007	0 - 40mils	2.0mils
K0003230M015	0 - 1500µm	75.0µm	-	-	-
K0003230M011	0 - 2000µm	100µm	-	-	-
K0003230M012	0 - 3000µm	150µm	-	-	-
Dimensions	50 x 30mm (1.97 x 1.18")				
Weight	220g (7.76oz)				
Packing List	Wet Film Wheel, storage case and operating instructions				
<i>Can be used in accordance with: (see Standards Explained inside Front Cover)</i>					
ASTM D 1212-A, AS/NZS 1580.107.3, BS 3900-C5-1B, ISO 2802-1B, NFT 30-125					

### Accessories

KT003230N003	15cm (6") Wet Film Wheel Handle
KT003230N002	50cm (19") Wet Film Wheel Handle

## Elcometer 3230 Coil Coating Wet Film Wheels

This instrument is similar to the Elcometer 3230 Wet Film Wheel, but is designed for use in the coil coating process. The outer wheels are knurled to allow measurements to be taken on slippery coatings or on fast moving substrates.

By rolling the gauge through a wet coating, the centre wheel eventually touches the film. This point on the scale indicates the thickness.

A convenient mounting handle for the wheel is available in two lengths; 15cm (6") & 50cm (19"); please order separately.

When the volume to solids ratio of the coating is known (generally found on the product data sheet supplied by the manufacturer), the wet film thickness can be used to predict the dry film thickness.



### Technical Specification

	Metric		Imperial		
Part Number	Scale Range	Graduations	Part Number	Scale Range	Graduations
<a href="#">K0003230M017</a>	0 - 50µm	2.5µm	<a href="#">K0US3230M017</a>	0 - 2mils	0.1mils
<a href="#">K0003230M018</a>	0 - 100µm	5.0µm	<a href="#">K0US3230M018</a>	0 - 4mils	0.2mils
<a href="#">K0003230M019</a>	0 - 300µm	15.0µm	<a href="#">K0US3230M019</a>	0 - 12mils	0.5mils
Dimensions	50 x 30mm (1.97 x 1.18")				
Weight	220g (7.76oz)				
Packing List	Wet Film Wheel, storage case and operating instructions				
<i>Can be used in accordance with: (see Standards Explained inside Front Cover)</i>					
<a href="#">ASTM D 1212-A</a> , <a href="#">BS 3900-C5-1B</a> , <a href="#">ISO 2808-1B</a> , <a href="#">NFT 30-125</a>					

### Accessories

- [KT003230N003](#) 15cm (6") Wet Film Wheel Handle
- [KT003230N002](#) 50cm (19") Wet Film Wheel Handle

Customers who purchased Elcometer Wet Film Wheels also purchased:



◀ Elcometer Adhesion Testers, page 216 - 226

Elcometer Pinhole Gauges, page 227 - 238



## Powder Thickness Measurement - uncured

A powder coating has many advantages over a wet coating system. Ensuring that the end product has the correct levels of adhesion and appearance - in particular gloss and colour - is dependent upon the thickness of the powder prior to the curing process and the temperature profile within the oven.

Measuring the thickness of the powder, however, is difficult as touching it changes the powder thickness by compressing it under the force. The solution is an Uncured Powder Film Comb or Gauge.

- Little or no waste - excess or over-sprayed powder may be recycled and reused.
- No solvents - tighter environmental controls of VOC emissions and legislation increases the need to use less or no solvents.

### Elcometer 155 Uncured Powder Film Comb

Available in four scale ranges, the Elcometer 155 is designed to measure uncured powder coating film thickness. This enables the application system to be set up and fine tuned prior to the curing process. In turn, this will reduce the amount of scrap and over-spray.

Place the comb into the powder and slide the comb along the surface. The measurement points (or teeth) are pointed and allow the powder to flow around them. The thickness of the powder lies between the highest value where a drag mark is visible and the lowest value where a drag mark has not been produced.

Note: The thickness of a coating prior to cure is not the same value after curing but there is a correlation. The powder comb is suitable as a guide only.

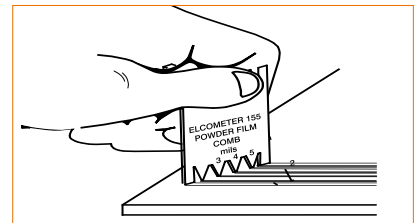
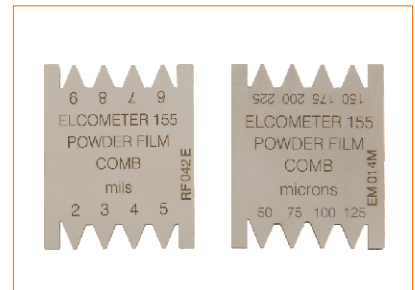

#### Technical Specification

**C.A** certificate available

Part Number	Description	Range
B15513573-5	Elcometer 155 Metric Powder Film Comb	50 - 255µm
B15513573-6	Elcometer 155 Metric Powder Film Comb	225 - 1250µm
B15513573-1	Elcometer 155 Imperial Powder Film Comb	2 - 9 mils
B15513573-2	Elcometer 155 Imperial Powder Film Comb	9 - 50mils
B15513573-10	Metric Comb Set (2 combs)	50 - 225µm and 225 - 1250µm
B15513573-9	Imperial Comb Set (2 combs)	2 - 9mils and 9 - 50mils
Accuracy	±5µm (±0.2mil)	
Dimensions	38mm x 46mm (1.5" x 1.8")	
Weight	18g (0.6oz)	
Packing List	Elcometer 155 Powder Comb and powder comb wallet for two combs	

Can be used in accordance with: (see Standards Explained inside Front Cover)

**ASTM D7378-A**

The Elcometer 155 is not available for sale in the USA

## Elcometer 550 Non-Contact Uncured Powder Gauge

The Elcometer 550 offers the user an unrivalled approach to measuring uncured powder thickness using unique ultrasonic technology - without touching the powder.

This gauge is designed to show the value of the cured film thickness by the measurement of the uncured powder coating on smooth flat or curved metallic surfaces such as steel and aluminium and flat, rigid materials such as MDF. The shrinkage that occurs when the powder cures in the oven is taken into account in the calibration of the gauge and the thickness displayed is the final coating thickness after cure.

### Features:

- Use of ultrasonic technology to measure the thickness of the uncured powder coating - without touching the surface
- Fast and easy to use
- Improves quality and saves time and money
- Can be used on all metallic and rigid non-metallic surfaces
- Helps to avoid edge runs and orange peel effect by improved monitoring and control
- Optimises powder application process for maximum efficiency



### Technical Specification

Part Number	Description
A550----1	Elcometer 550 Non-Contact Powder Gauge (UK 240V)
A550----2	Elcometer 550 Non-Contact Powder Gauge (EUR 220V)
A550----3	Elcometer 550 Non-Contact Powder Gauge (US 110V)
Display	Graphic LCD, 128 x 64 pixels with backlight
Power Supply	Rechargeable battery (NiMh 2100mAh)
Measurement Range	30 - 110µm (1.2 - 4.3mils)
Measurement Accuracy	±5µm (±0.2mil)
Measurement Offset Distance	Approximately 18mm (0.7")
Measurement Area	1mm <sup>2</sup> (0.04sq in)
Operating Temperature	5°C to 45°C (40°F to 113°F)
Resolution	1µm (0.1mil)
Dimensions	230 x 105 x 355mm (9 x 4.1 x 14")
Weight	1186g (2.6lb)
Packing List	Elcometer 550 Gauge with rechargeable battery, battery charger unit with separate mains power supply, ultrasonic probe and lead, calibration standard, carry case and operating instructions

*Can be used in accordance with: (see Standards Explained inside Front Cover)*

**ASTM D7378-C**

### Accessories

T55016863	Calibration Block
-----------	-------------------

USA Patent Number 6250159 B1

## Dry Film Thickness

Dry Film Thickness is probably the most critical measurement in the coatings industry. It provides vital information as to the expected life of the substrate, the product's fitness for purpose, its appearance and ensures compliance with a host of International Standards.

Quality systems, such as those described in ISO 9000, ISO 17025 and Guide 25, require that gauges be properly controlled, logged and in calibration. Increasingly, users are specifying that the readings taken by gauges are traceable to National Standards.

Calibration foils or 'shims' are the most convenient way of creating a coating thickness standard on the substrate material, surface finish or form. This is the ideal method for adjusting the calibration of the coating thickness gauge to ensure the greatest possible accuracy.

In some cases, it may be difficult or impractical to obtain an uncoated substrate. Pre-coated thickness standards or Zero Test Plates, used in conjunction with a set of foils, are ideal to test a coating thickness gauge's functionality and calibration.

In 1947, before the introduction of consumer electronics, Elcometer launched one of the world's first non-destructive coating thickness gauges, the Elcometer 101.

For more than 6 decades, the design and production qualities of this rugged and reliable instrument have been the watchwords of all our products and these philosophies are still held today.

Dry Film Coating Thickness is a critical measurement in all industry sectors and can be categorised as follows:

- **Digital:**

The most widely used as it is generally the most accurate and can be used to measure the coating on almost any substrate, whether ferrous or non-ferrous

- **Mechanical:**

Still widely used, particularly in areas where no electrical instruments are permitted or high temperatures prevail

- **Destructive:**

Used primarily in multi-coat procedures and non-metallic substrates



## Elcometer 311 Automotive Refinishing Gauge

The Elcometer 311 has been specifically designed to meet the requirements of today's automotive refinishing market and is available in two models.

The Ferrous instrument is ideal for measuring coatings on steel body panels. The FNF instrument enables the user to measure on both steel and aluminium panels using one gauge with automatic switching.

Pre-calibrated on steel and aluminium car body panels, the Elcometer 311 is very easy to use. Checkpieces are supplied with each instrument to verify accuracy.

- Designed specifically to meet the requirements of the automotive industry
- Ferrous (F) and Ferrous/Non Ferrous (FNF) gauges available
- Pre-calibrated on automotive steel and aluminium
- Big Foot™ integral probe for stable, repeatable readings
- Scale range of 0-500µm (0-20mils)
- Auto On/Off
- Ferrous (F) checkpiece included to verify performance - the FNF gauge is also supplied with a non-ferrous (N) checkpiece
- Available in Metric or Imperial versions



### Technical Specification



Part Number		Description
Metric	Imperial	
<b>A311FM</b>	<b>A311FE</b>	Elcometer 311 Automotive Refinishing Gauge (Ferrous)
<b>A311FNFM</b>	<b>A311FNFE</b>	Elcometer 311 Automotive Refinishing Gauge (FNF)
Scale Range		0 - 500µm (0 - 20mils)
Resolution		10µm (0.5mil)
Accuracy		±5% or ±20µm (±5% or ±1.0mil)
Probe Type		Integral with auto On/Off
Operating Temperature		0° to 50°C (32°F to 120°F)
Speed of Readings		30 per minute
Weight		115g (4.05oz)
Battery Type		2 x LR03 (AAA) Alkaline Batteries. Battery life: 20 hours
Dimensions		120 x 56 x 24mm (4.75 x 2.2 x 0.95")
Packing List		Elcometer 311F or Elcometer 311FNF Automotive Refinishing Gauge, 2 x LR03 (AAA) alkaline batteries, steel checkpiece, aluminium checkpiece (FNF model) with foil, carry case and operating instructions

### Accessories

<b>T99916925</b>	Steel (F) Checkpiece	<b>T99916901</b>	Aluminium (N) Checkpiece
<b>T99016898</b>	Calibration Foil (Metric) 125µm	<b>T99016897</b>	Calibration Foil (Imperial) 5mils

## Elcometer 415 Paint and Powder Gauge

The Elcometer 415 Paint and Powder Coating Thickness Gauge provides a simple, accurate and reliable way to measure coatings on all smooth ferrous and non-ferrous metal surfaces. The gauge auto-switches to read on either ferrous or non-ferrous substrates. This is ideal for measuring paint or powder on both steel and aluminium surfaces such as car body panels or in a powder shop.

The gauge features a large, easy-to-read screen and is capable of taking more than 60 readings per minute. The central Bigfoot™ internal probe, with the integrated V-groove, allows repeatable readings on both flat and curved surfaces. On screen instructions, in over 20 languages, make the gauge useable straight from the box.

### Features:

- Angled, large display for viewing from all angles
- Metric or Imperial measurements - displays readings in mils or microns
- Fast and accurate with more than 60 readings per minute
- Factory calibrated for use straight from the box, with 4 calibration foils supplied
- Simple “Zero Cal” feature with fixed calibration setting if access to the uncoated substrate is not available
- Ergonomic design for maximum comfort
- Bigfoot™ probe for repeatable results
- On screen instructions in over 20 languages



### Technical Specification

**T** certificate available

Part Number	Description
<b>A415FNFI1</b>	Elcometer 415 Paint and Powder Coating Thickness Gauge
<b>A415FNFI1AUTO</b>	Elcometer 415 Automotive Gauge (complete with F & N calibration plates)
Range	0 to 1000µm (0 to 40mils)
Resolution	1µm (0.1mil)
Accuracy	±3% or ±3µm (±0.12mil)
Measurement Speed	Greater than 60 readings per minute
Operating Temperature (ambient)	0°C to 50°C (32°F to 120°F)
Maximum Operating Temperature (probe)	80°C (176°F)
Storage Temperature	-10°C to 55°C (14°F to 130°F)
Case	High impact ABS plastic
Batteries	2 x LR03 (AAA) alkaline dry batteries or rechargeable equivalents
Weight	130g (4.1oz)
Dimensions	110 x 75 x 35mm (4.3 x 3 x 1.38")
Packing List	Elcometer 415 gauge, 4 x calibration foils, soft carry case, 2 x LR03 batteries & operating instructions. The Elcometer 415AUTO has 2 calibration zero plates

*Can be used in accordance with: (see Standards Explained inside Front Cover)*

ASTM B 244, **ASTM B 499**, **ASTM D 1400**, **ASTM D 1186-B**, BS 5411-(3) (11), BS 3900 C5, DIN 50984, DIN 50981, **ISO 1461**, **ISO 2178**, **ISO 2360**, **ISO 2808**, SSPC-PA2 2004

## Elcometer 456 Coating Thickness Gauge

This flagship product is available in any combination of Basic, Standard and Top functionality, and as either Integral (inbuilt), Separate or Plug in integral PINIP™ probes to meet your specifications.

With its enhanced menu screens and the introduction of *Bluetooth*® wireless technology, the Elcometer 456 remains the most advanced, hand held coating thickness gauge available.



*Bluetooth*® wireless technology  
for cable free data transfer

Fast reading rate of more  
than 60 readings per minute



Readings can be downloaded  
to a PC or PDA and reports  
created in seconds

Intuitive menus in multiple languages  
enables use straight from the box





IMO PSPC ready

Accurate and repeatable results

Each model is available with or without memory

A wide range of integral or separate probe versions

Gauges can measure on steel (ferrous - F) or aluminium and other non-ferrous metals (non-ferrous - N) or both

Large backlit screen for easy viewing in dark environments

Rugged and ergonomic, each gauge is designed to withstand the harshest environments



Elcometer 456 gauges have either an inbuilt probe (Integral gauge) or a separate probe (Separate gauge).

Memory versions are capable of storing up to 40,000 readings in up to 999 batches.



The Integral Gauge features an inbuilt Bigfoot™ probe for stable placement, allowing for consistent and repeatable results.

Available with or without memory and as ferrous (F), non-ferrous (N) or both ferrous/non-ferrous (FNF).



Separate probe versions have an extensive range of plug in probes for measurements of a diverse range of coating thicknesses, metal substrates and shapes. Available as F, N or FNF. Waterproof probes are also available.



The PINIP™ probe can be screwed into the base of any separate probe version converting it into an integral gauge for single handed operations. PINIP™ versions are also available for high temperature substrates.



The Elcometer 456 Standard and Top models now come with *Bluetooth*® wireless technology. Instant transmission to your PC or hand held data device is now possible - no more cables required. RS232 data output is available on all models.



Provides the user with continuous monitoring of the 90/10 rule against the NDFT value, including pass/fail confirmation, as required by IMO PSPC for dedicated seawater ballast tanks.

# Dry Film Thickness

elcometer®

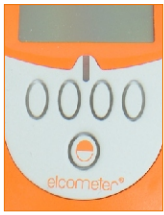

Hi/Low limit settings allow use as a simple pass/fail gauge as indicated by a green/red LED, ideal for poor visibility areas.



Ferrous (F) gauges can be used with any ferrous probe. Non-Ferrous (N) gauges can be used with any non-ferrous probe. FNF gauges can be used with Ferrous, Non-Ferrous and Dual FNF probes.

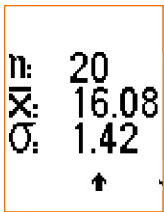

The on screen statistics include: maximum and minimum value, average, total number of readings, coefficient of variation and standard deviation.



Backlit screen and large fonts allow clear viewing of readings in any environment.

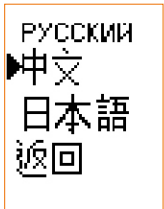

The intuitive menu system in over 25 languages makes this a truly international gauge.



ElcoMaster™ Software data management system for data analysis and reporting.

ElcoMaster™ also stores data from other Elcometer gauges.

See pages 200 - 201 for details.

## Technical Specification

**T** certificate available

Measurement Speed	Greater than 60 readings per minute
Display	STN Graphics (LCD), 128 x 64 pixels; 19.8 x 39.6mm (0.78" x 4.56")
Battery Type	2 x AAA (LR03). Rechargeable batteries can be used
Battery Life	30 - 40 hours continuous use with alkaline batteries. (Enough for 15,000 - 20,000 readings at an average of 8 readings per minute)
Minimum Substrate Thickness	Ferrous: 0.3mm (12mils); Non-Ferrous: 0.1mm (4mils) unless special calibration adjustment is made
Measurement Options	Ferrous (F), Non-Ferrous (N) or Dual (FNF)
Operating Temperature	0°C - 50°C (32°F - 120°F)
Dimensions	128 x 68 x 28mm (5.0 x 2.7 x 1.1")
Weight (including batteries)	130g (4.58oz)
Packing List	Elcometer 456 Integral Gauge (supplied with a range of calibration foils appropriate for the gauge) or Separate Gauge, carry pouch, wrist harness, 2 x LR03 batteries, ElcoMaster™ and ElcoMaster™ Mobile Software (Standard and Top models only) and operating instructions

## Features

	Basic	Standard	Top
Fast, accurate reading rate - >60 readings per minute	■	■	■
Auto substrate recognition on FNF models	■	■	■
Integral and separate probe models available	■	■	■
Switchable Metric / Imperial units - mm, µm, mils, inches	■	■	■
Backlight - user selectable, ideal for dark environments	■	■	■
Intuitive menu driven display with adjustable text size	■	■	■
Maximised gauge reading display	■	■	■
Languages - menus in over 25 languages	■	■	■
User definable limits - Green/Red LEDs for Pass/Fail inspection		■	■
User definable on-screen statistics - number of readings, mean, standard deviation, coefficient of variation, minimum, maximum	■	■	■
On-screen calibration instructions	■	■	■
Calibration options for:			
Smooth, rough and special substrates	■	■	■
Single and 2-point calibration	■	■	■
Zero Offset*	■	■	■
90/10 rule with autocheck feature - to meet IMO MSC.215 (82) and MSC.216(82) Performance Standard for Protective Coatings	■	■	■
Predefined calibration routines to meet:		■	■
ISO, SSPC, Swedish & Australian Standards			
Memory		250 readings in one batch	50,000 readings in up to 999 batches
Memory size			
Individual reading mode		■	■
Counted average mode		■	■
Individual readings review		■	■
Date and time stamp with clock and alarm functions - readings can be stamped including the last calibration date and time			■
Batch calibrations - each batch can be programmed with a different calibration			■
Batch calibration cloning - copy calibrations between batches			■
Data Output			
RS232	■	■	■
Bluetooth®		■	■
Data output modes			
Immediate Output - each reading is transmitted as it is taken	■	■	■
Batch Output - send data by batches on command		■	■
ElcoMaster™ Software and ElcoMaster™ Mobile Software		■	■

\* Zero Offset, USA Patent Number 6243661 Zero Offset subtracts a user defined value from the reading. Ideal for ISO19840

## Elcometer 456 Integral Gauge

The Elcometer 456 Integral Gauge with integrated V-groove, is ideal for single handed operation. The wide footprint of the Bigfoot™ probe provides greater stability when taking readings on flat and curved surfaces.

Standard and Top models are supplied with *Bluetooth*® wireless technology for easy and simple connectivity to a PC or *Bluetooth*® enabled PDA†. RS232 data output is available on all models using an optional gauge-to-PC cable.

For PCs or laptops without a *Bluetooth*® interface, a USB-to-*Bluetooth*® adaptor is available as an optional accessory.

For a full list of features and technical specifications, see pages 188 - 191.



### Integral Gauge Options

**T** certificate\* available

Part Number	Description	Metric	Imperial
A456FBI1	Basic Ferrous Integral Scale 1	0 - 1500µm	0 - 60mils
A456FSI1	Standard Ferrous Integral Scale 1 with <i>Bluetooth</i> ®	0 - 1500µm	0 - 60mils
A456FTI1	Top Ferrous Integral Scale 1 with <i>Bluetooth</i> ®	0 - 1500µm	0 - 60mils
A456FBI12	Basic Ferrous Integral Scale 1 2 - High Resolution	0 - 5mm	0 - 200mils
A456FSI12	Standard Ferrous Integral Scale 1 2 - High Resolution with <i>Bluetooth</i> ®	0 - 5mm	0 - 200mils
A456FTI12	Top Ferrous Integral Scale 1 2 - High Resolution with <i>Bluetooth</i> ®	0 - 5mm	0 - 200mils
A456FBI3	Basic Ferrous Integral Scale 3	0 - 13mm	0 - 500mils
A456FSI3	Standard Ferrous Integral Scale 3 with <i>Bluetooth</i> ®	0 - 13mm	0 - 500mils
A456FTI3	Top Ferrous Integral Scale 3 with <i>Bluetooth</i> ®	0 - 13mm	0 - 500mils
A456NBI1	Basic Non-Ferrous Integral Scale 1	0 - 1500µm	0 - 60mils
A456NSI1	Standard Non-Ferrous Integral Scale 1 with <i>Bluetooth</i> ®	0 - 1500µm	0 - 60mils
A456NTI1	Top Non-Ferrous Integral Scale 1 with <i>Bluetooth</i> ®	0 - 1500µm	0 - 60mils
A456FNFB11	Basic Dual Basic Integral FNF Scale 1	0 - 1500µm	0 - 60mils
A456FNFSI1	Standard Dual Standard Integral FNF Scale 1 with <i>Bluetooth</i> ®	0 - 1500µm	0 - 60mils
A456FNFTI1	Top Dual Top Integral FNF Scale 1 with <i>Bluetooth</i> ®	0 - 1500µm	0 - 60mils

Can be used in accordance with: (see Standards Explained inside Front Cover)

AS 2331.1.4, AS 3894.3-B, AS/NZS 1580.108.1, ASTM B 499, ASTM D 1186-B, ASTM D 1400, ASTM D 7091, ASTM E 376, ASTM G 12, BS 3900-C5, BS 3900-C5-6Aa, BS 5411-11, BS 5411-3, BS 5599, DIN 50981, DIN 50984, EN 13523-1, IMO MSC.215(82), IMO MSC.216 (82), ISO 1461, ISO 19840, ISO 2063, ISO 2360, ISO 2808-7C, ISO 2808-7D, NF T30-124, NSI 0009-32, NSTM CH 631, SMS 6310-081-015, SS 184160, SSPC PA 2, US Navy PPI 63101-000

† PDAs require Windows® Mobile 5.0 or Windows® Mobile 6 Professional or later

\* As the gauge is calibrated by the user, calibration certificates are available with the foils only

A comprehensive range of both nominal and certified foils together with zero test plates is available to ensure the accuracy of the gauges, see pages 208 - 210 for full details.

### Accessories

**T99920130** USB *Bluetooth*® Transmitter/Receiver for PC    **T99916716** USB Serial RS232 Cable Adaptor for PC

## Elcometer 456 Separate Gauge

The Elcometer 456 Separate Gauge is the most versatile gauge for the measurement of a wide range of coatings on metal substrates. The probes are fully interchangeable; any ferrous gauge accepts any ferrous probe, any non-ferrous gauge accepts any non-ferrous probe and FNF models will accept all Elcometer 456 probes. Using the unique plug-in integral probe (PINIP™) the user has all the versatility of a separate and integral probe in a single gauge.

Standard and Top models are supplied with *Bluetooth*® wireless technology for easy connectivity to a PC or *Bluetooth*® enabled PDA†. For PCs or laptops without a *Bluetooth*® interface, a USB-to-*Bluetooth*® adaptor is available as an optional accessory. Data output via RS232 is available on all models using an optional gauge-to-PC cable.

A wide range of probes is available to meet your specific application, see pages 194 - 198 for information.

For a full list of features and technical specifications, see pages 188 - 191.



### Separate Gauge Options

**T** certificate\* available

Part Number	Description
A456FBS	Basic Ferrous Separate Gauge
A456FSS	Standard Ferrous Separate Gauge with <i>Bluetooth</i> ®
A456FTS	Top Ferrous Separate Gauge with <i>Bluetooth</i> ®
A456NBS	Basic Non-Ferrous Separate Gauge
A456NSS	Standard Non-Ferrous Separate Gauge with <i>Bluetooth</i> ®
A456NTS	Top Non-Ferrous Separate Gauge with <i>Bluetooth</i> ®
A456FNFBS	Basic Dual FNF Separate Gauge
A456FNFSS	Standard Dual FNF Separate Gauge with <i>Bluetooth</i> ®
A456FNFTS	Top Dual FNF Separate Gauge with <i>Bluetooth</i> ®

Can be used in accordance with: (see Standards Explained inside Front Cover)

AS 2331.1.4, AS 3894.3-B, AS/NZS 1580.108.1, ASTM B 499, ASTM D 1186-B, ASTM D 1400, ASTM D 7091, ASTM E 376, ASTM G 12, BS 3900-C5, BS 3900-C5-6Aa, BS 5411-11, BS 5411-3, BS 5599, DIN 50981, DIN 50984, EN 13523-1, IMO MSC.215(82), IMO MSC.216 (82), ISO 1461, ISO 19840, ISO 2063, ISO 2360, ISO 2808-7C, ISO 2808-7D, NF T30-124, NSI 0009-32, NSTM CH 631, SMS 6310-081-015, SS 184160, SSPC PA 2, US Navy PPI 63101-000

† PDAs require Windows® Mobile 5.0 or Windows® Mobile 6 Professional or later

\* As the gauge is calibrated by the user, calibration certificates are available with the probe only

A comprehensive range of both nominal and certified foils together with zero test plates is available to ensure the accuracy of the gauges, see pages 208 - 210 for full details.

### Accessories

T99920130 USB *Bluetooth*® Transmitter/Receiver for PC      T99916716 USB Serial RS232 Cable Adaptor for PC

## Elcometer 456 Separate Probe Range

A variety of probes and scale ranges is available for the Elcometer 456 Separate gauge. Probes are supplied complete with an appropriate set of calibration foils.



### STANDARD PROBES (F, N and FNF)

Available in Straight, Right Angle or Telescopic options and are suitable for most coating thickness requirements. Probe cables are also available in 5m (16.4ft) and 15m (49.2ft) lengths for the F1S and F1R probes. Telescopic probes extend from 410mm (16") to 1100mm (43"). Waterproof probes are also available.



### MINIATURE PROBES (F and N)

Ideal for taking measurements in hard to reach places, on small surface areas and on concrete reinforcement bars. Miniature probes are available in Straight, Right Angled, and 45° options with either 45mm (1.77") or 150mm (5.90") probe lengths.



### PINIP™ PROBES (F, N and FNF)

The Plug-In Integral Probe (PINIP™) has been designed to screw into the base of any Separate Elcometer 456 gauge to transform it into an integral unit for single handed operation. Its Bigfoot™ probe gives greater stability on large surface areas.

A High Temperature version for measuring coatings on hot ferrous substrates up to 250°C (480°F) is available and is supplied with high temperature calibration standards.

## Elcometer 456 Ferrous Probes











### Ferrous Probe Specifications

Max Operating Temperature	150°C (300°F) PINIP™ 80°C (176°F)
Storage Temperature	High Temperature PINIP™ 250°C (480°F)
Minimum Substrate Thickness	-10°C to 60°C (14°F to 140°F)

Part Number	Probe Type	Measuring Range	Accuracy	Resolution	Convex Surface Diameter	Concave Surface Radius	Headroom	Minimum Sample Diameter
T456F1S	Standard F1 S	0-1500µm (0-60mils)	±1-3% or ±2.5µm (±0.1mil)	0.1µm up to 100µm; 1µm 100-500µm (0.01mil up to 5mils; 0.1mil 5-60mils)	4mm (0.16")	25mm (0.98")	85mm (3.35")	4mm (0.16")
T456F12S	Standard F1 2 S Set as F1	0-1500µm (0-60mils)	±1-3% or ±2.5µm (±0.1mil)	0.1µm up to 100µm; 1µm 100-500µm (0.01mil up to 5mils; 0.1mil 5-60mils)	4mm (0.16")	25mm (0.98")	85mm (3.35")	4mm (0.16")
	Set as F2	0-5mm (0-200mils)	±1-3% or ±0.02mm (±1.0mil)	0.1µm up to 1mm; 10µm 1-5mm (0.1mil up to 50mils; 1mil 50-200mils)	4mm (0.16")	25mm (0.98")	89mm (3.50")	8mm (0.32")

S = Standard Probe RA = Right Angle Probe T = Telescopic Probe A = Anodising Probe

## Elcometer 456 Ferrous Probes (continued)

Part Number	Probe Type	Measuring Range	Accuracy	Resolution	Convex Surface Diameter	Concave Surface Radius	Headroom	Minimum Sample Diameter
<b>T456F1R</b> 	Standard F1 RA	0-1500µm (0-60mils)	±1-3% or ±2.5µm (±0.1mil)	0.1µm up to 100µm; 1µm 100-1500µm (0.01mil up to 5mils; 0.1mil 5-60mils)	4mm (0.16")	25mm (0.98")	28mm (1.10")	4mm (0.16")
<b>T456F12R</b> 	Standard F1 2 RA Set as F1	0-1500µm (0-60mils)	±1-3% or ±2.5µm (±0.1mil)	0.1µm up to 100µm; 1µm 100-1500µm (0.01mil up to 5mils; 0.1mil 5-60mils)	4mm (0.16")	25mm (0.98")	28mm (1.10")	4mm (0.16")
	Set as F2	0-5mm (0-200mils)	±1-3% or ±0.02mm (±1.0mil)	1µm up to 1mm; 10µm 1-5mm (0.1mil up to 50mils; 1mils 50-200mils)	4mm (0.16")	25mm (0.98")	32mm (1.26")	8mm (0.32")
<b>T456F1T</b> 	Standard F1 T	0-1500µm (0-60mils)	±1-3% or ±2.5µm (±0.1mil)	0.1µm up to 100µm; 1µm 100-1500µm (0.01mil up to 5mils; 0.1mil 5-60mils)	4mm (0.16")	25mm (0.98")	32mm (1.26")	4mm (0.16")
<b>T456F2T</b> 	Standard F2 T	0-5mm (0-200mils)	±1-3% or ±0.02mm (±1.0mil)	1µm up to 1mm; 10µm 1-5mm (0.1mil up to 50mils; 1mil 50-200mils)	4mm (0.16")	25mm (0.98")	36mm (1.42")	8mm (0.32")
<b>T456F3S</b> 	Standard F3 S	0-13mm (0-500mils)	±1-3% or ±0.05mm (±2.0mils)	1µm up to 2mm; 10µm 2-13mm (0.1mil to 100mils; 1mil 100-500mils)	15mm (0.59")	40mm (1.57")	102mm (4.02")	14mm (0.55")
<b>T456F6S</b> 	Standard F6 S	0-25mm (0-980mils)	±1-3% or ±0.1mm (±2.0mils)	10µm up to 2mm; 100µm 2-25mm (1mil to 100mils; 10mils 100-980mils)	35mm (1.38")	170mm (6.70")	150mm (5.9")	51mm (2.0")
<b>T456F1P</b> 	PINIP™ F1	0-1500µm (0-60mils)	±1-3% or ±2.5µm (±0.1mil)	0.1µm up to 100µm; 1µm 100-1500µm (0.01mil to 5mils; 0.1mil 5-60mils)	4mm (0.16")	60mm (2.36")	155mm (6.09")	4mm (0.16")
<b>T456F12P</b> 	PINIP™ F1 2 Set as F1	0-1500µm (0-60mils)	±1-3% or ±2.5µm (±0.1mil)	0.1µm up to 100µm; 1µm 100-1500µm (0.01mil to 5mils; 0.1mil 5-60mils)	4mm (0.16")	60mm (2.36")	159mm (6.25")	4mm (0.16")
	Set as F2	0-5mm (0-200mils)	±1-3% or ±0.02mm (±1mil)	1µm up to 1mm; 10µm 1-5mm (0.1mil to 50mils; 1mil 50-200mils)	4mm (0.16")	60mm (2.36")	159mm (6.25")	8mm (0.32")
<b>T456F12PHT</b> 	PINIP™ F1 2 Hi Temp Set as F1	250°C (480°F) 0-1500µm (0-60mils)	±1-3% or ±2.5µm (±0.1mil)	0.1µm up to 100µm; 1µm 100-1500µm (0.01mil to 5mils; 0.1mil 5-60mils)	4mm (0.16")	60mm (2.36")	155mm (6.09")	4mm (0.16")
	Set as F2	0-5mm (0-200mils)	±1-3% or ±0.02mm (±1mil)	1µm up to 1mm; 10µm 1-5mm (0.1mil to 50mils; 1mil 50-200mils)	4mm (0.16")	60mm (2.36")	159mm (6.25")	8mm (0.32")
<b>T456F3P</b> 	PINIP™ F3	0-13mm (0-500mils)	±1-3% or ±0.05mm (±2mils)	1µm up to 2mm; 10µm 2-13mm (0.1mil to 100mils; 1mil 100-500mils)	15mm (0.59")	45mm (1.77")	169mm (6.65")	14mm (0.55")

## Elcometer 456 Ferrous Probes (continued)

Part Number	Probe Type	Measuring Range	Accuracy	Resolution	Convex Surface Diameter	Concave Surface Radius	Headroom	Minimum Sample Diameter
<b>T456FM3---A</b>	Mini Straight Probe 45mm (1.77") <sup>†</sup>	0-500µm (0-20mils)	±1-3% or ±2.5µm (±0.1mil)	0.1µm up to 100µm; 1µm 100-500µm (0.01mil up to 5mils; 0.1mil 5-20mils)	1.5mm (0.06")	6.5mm (0.26")	6mm (0.24")	3mm (0.12")
<b>T456FM3---C</b>	Mini Straight Probe 150mm (5.90") <sup>†</sup>	0-500µm (0-200mils)	±1-3% or ±2.5µm (±0.1mil)	0.1µm up to 100µm; 1µm 100-500µm (0.01mil up to 5 mils; 0.1mil 5-20mils)	1.5mm (0.06")	6.5mm (0.26")	6mm (0.24")	3mm (0.12")
<b>T456FM3R45A</b>	Mini 45° Probe 45mm (1.77") <sup>†</sup>	0-500µm (0-20mils)	±1-3% or ±2.5µm (±0.1mil)	0.1µm up to 100µm; 1µm 100-500µm (0.01mil up to 5mils; 0.1mil 5-20mils)	1.5mm (0.06")	6.5mm (0.26")	18mm (0.71")	3mm (0.12")
<b>T456FM3R45C</b>	Mini 45° Probe 150mm (5.90") <sup>†</sup>	0-500µm (0-20mils)	±1-3% or ±2.5µm (±0.1mil)	0.1µm up to 100µm; 1µm 100-500µm (0.01mil up to 5mils; 0.1mil 5-20mils)	1.5mm (0.06")	6.5mm (0.26")	18mm (0.71")	3mm (0.12")
<b>T456FM3R90A</b>	Mini 90° Probe 45mm (1.77") <sup>†</sup>	0-500µm (0-20mils)	±1-3% or ±2.5µm (±0.1mil)	0.1µm up to 100µm; 1µm 100-500µm (0.01mil up to 5mils; 5-0.1mil 20mils )	1.5mm (0.06")	6.5mm (0.26")	16mm (0.63")	3mm (0.12")
<b>T456FM3R90C</b>	Mini 90° Probe 150mm (5.90") <sup>†</sup>	0-500µm (0-20mils)	±1-3% or ±2.5µm (±0.1mil)	0.1µm up to 100µm; 1µm 100-500µm (0.01mil up to 5mils; 0.1mil 5-20mils )	1.5mm (0.06")	6.5mm (0.26")	16mm (0.63")	3mm (0.12")

<sup>†</sup>Additional probe lengths are available upon request. For further information please contact Elcometer.

F12 Probe Patents GB 2367135, US 6762603

## Elcometer 456 Ferrous Waterproof Probes\*

Part Number	Probe Type	Measuring Range	Accuracy	Resolution	Convex Surface Diameter	Concave Surface Radius	Headroom	Minimum Sample Diameter
<b>T456F1SW</b>	1m length	Standard F1 S or F12S set as F1	±1-3% or ±2.5µm (±0.1mil)	0.1µm up to 100µm; 1µm 100-1500µm (0.01mil to 5mils; 0.1mil 5-60mils)	4mm (0.16")	40mm (0.98")	130mm (5.12")	4mm (0.16")
<b>T456F1SW-5</b>	5m length							
<b>T456F1SW-15</b>	15m length							
<b>T456F12SW</b>	1m length	Standard F12 S set as F2	±1-3% or ±0.02mm (±1.0mil)	1µm up to 1mm; 10µm 1-5mm (0.1mil to 50mils; 1mil 50-200mils)	4mm (0.16")	40mm (0.98")	130mm (5.12")	8mm (0.32")
<b>T456F12SW-5</b>	5m length							
<b>T456F12SW-15</b>	15m length							
<b>T456F3SW</b>	1m length	0-13mm (0-500mils)	±1-3% or ±0.05mm (±2.0mils)	1µm up to 2mm; 10µm 2-13mm (0.1mil to 100mils; 1mil 100-500mils)	15mm (0.6")	40mm (0.98")	130mm (5.12")	14mm (1.55")
<b>T456F3SW-5</b>	5m length							
<b>T456F3SW-15</b>	15m length							

\*Although the waterproof probes and cables are waterproof to a rating of IP68, the gauge should remain above water at all times.









S = Standard Probe RA = Right Angle Probe T = Telescopic Probe A = Anodising Probe



## Elcometer 456 Non-Ferrous Probes

### Non-Ferrous Probe Specifications

Max Operating Temperature	Standard and Mini Probes: 150°C (300°F) PINIP: 80°C (176°F)
Storage Temperature	-10°C to 60°C (14°F to 140°F)
Minimum Substrate Thickness	0.1mm (4mils)

Part Number	Probe Type	Measuring Range	Accuracy	Resolution	Convex Surface Diameter	Concave Surface Radius	Headroom	Minimum Sample Diameter
 T456N1S	Standard N1 S	0-1500µm (0-60mils)	±1-3% or ±2.5µm (±0.1mil)	0.1µm up to 100µm; 1µm 100-1500µm (0.01mil up to 5mils; 0.1mil 5-60mils)	35mm (1.38")	25mm (0.98")	85mm (3.35")	6mm (0.24")
 T456N1R	Standard N1 RA	0-1500µm (0-60mils)	±1-3% or ±2.5µm (±0.1mil)	0.1µm up to 100µm; 1µm 100-1500µm (0.01mil up to 5mils; 0.1mil 5-60mils)	35mm (1.38")	25mm (0.98")	28mm (1.10")	6mm (0.24")
 T456N1AS	Standard N1 A	0-1500µm (0-60mils)	±1-3% or ±2.5µm (±0.1mil)	0.1µm up to 100µm; 1µm 100-1500µm (0.01mil up to 5mils; 0.1mil 5-60mils)	35mm (1.38")	25mm (0.98")	85mm (3.35")	6mm (0.24")
 T456N2S	Standard N2 S	0-5mm (0-200mils)	±1-3% or ±0.02mm (±1.0mil)	1µm up to 1mm; 10µm 1-5mm (0.1mil up to 50mils; 1mil 50-200mils)	100mm (3.97")	150mm (5.90")	85mm (3.35")	14mm (0.55")
 T456N6S	Standard N6 S	0-30mm (0-1200mils)	±1-3% or ±0.05mm (±2.0mils)	10µm up to 2mm; 100µm 2-30mm (1mil up to 100mils; 10mils 100-1200mils)	-	400mm (15.8")	160mm (6.3")	58mm (2.3")
 T456N1P	PINIP™ N1	0-1500µm (0-60mils)	±1-3% or ±2.5µm (±0.1mil)	0.1µm up to 100µm; 1µm 100-1500µm (0.01mil up to 5mils; 0.1mil 5-60mils)	35mm (1.38")	50mm (1.97")	155mm (6.09")	6mm (0.24")
 T456NM3---A	Mini Straight Probe 45mm (1.77") <sup>†</sup>	0-500µm (0-20mils)	±1-3% or ±2.5µm (±0.1mil)	0.1µm up to 100µm; 1µm 100-500µm (0.01mil up to 5mils; 0.1mil 5-20mils)	3mm (0.12")	25mm (0.98")	6mm (0.24")	4mm (0.16")
 T456NM3---C	Mini Straight Probe 150mm (5.90") <sup>†</sup>	0-500µm (0-20mils)	±1-3% or ±2.5µm (±0.1mil)	0.1µm up to 100µm; 1µm 100-500µm (0.01mil up to 5mils; 0.1mil 5-20mils)	3mm (0.12")	25mm (0.98")	6mm (0.24")	4mm (0.16")
 T456NM3R45A	Mini 45° Probe 45mm (1.77") <sup>†</sup>	0-500µm (0-20mils)	±1-3% or ±2.5µm (±0.1mil)	0.1µm up to 100µm; 1µm 100-500µm (0.01mil up to 5mils; 0.1mil 5-20mils)	3mm (0.12")	25mm (0.98")	18mm (0.71")	4mm (0.16")

<sup>†</sup>Additional probe lengths are available on request. For further information please contact Elcometer.

S = Standard Probe RA = Right Angle Probe T = Telescopic Probe A = Anodising Probe

FNF Probe Patents GB 2306009, US 5886522

## Elcometer 456 Non-Ferrous Probes (continued)

Part Number	Probe Type	Measuring Range	Accuracy	Resolution	Convex Surface Diameter	Concave Surface Radius	Headroom	Minimum Sample Diameter
<b>T456NM3R45C</b>	Mini 45° Probe 150mm (5.90") <sup>†</sup>	0-500µm (0-20mils)	±1-3% or ±2.5µm (±0.1mil)	0.1µm up to 100µm; 1µm 100-500µm (0.01mils up to 5mils; 0.1mils 5-20mils)	3mm (0.12")	25mm (0.98")	18mm (0.71")	4mm (0.16")
<b>T456NM3R90A</b>	Mini 90° Probe 45mm (1.77") <sup>†</sup>	0-500µm (0-20mils)	±1-3% or ±2.5µm (±0.1mil)	0.1µm up to 100µm; 1µm 100-500µm (0.01mils up to 5mils; 0.1mils 5-20mils)	3mm (0.12")	25mm (0.98")	16mm (0.63")	4mm (0.16")
<b>T456NM3R90C</b>	Mini 90° Probe 150mm (5.90") <sup>†</sup>	0-500µm (0-20mils)	±1-3% or ±2.5µm (±0.1mil)	0.1µm up to 100µm; 1µm 100-500µm (0.01mils up to 5mils; 0.1mils 5-20mils)	3mm (0.12")	25mm (0.98")	16mm (0.63")	4mm (0.16")

<sup>†</sup>Additional probe lengths are available upon request. For further information please contact Elcometer.

## Elcometer 456 Dual Ferrous / Non-Ferrous

### FNF Probe Specifications

Max Operating Temperature	Standard Probes: 150°C (300°F)    PINIP: 80°C (176°F)
Storage Temperature	-10°C to 60°C (14°F to 140°F)
Minimum Substrate Thickness	Ferrous: 0.3mm (12mils)    Non-Ferrous: 0.1mm (4mils)

Part Number	Probe Type	Measuring Range	Accuracy	Resolution	Convex Surface Diameter	Concave Surface Radius	Headroom	Minimum Sample Diameter
<b>T456FNF1S</b>	N Mode	0-1500µm (0-60mils)	±1-3% or ±2.5µm (±0.1mil)	0.1µm up to 100µm; 1µm 100-1500µm	38mm (1.50")	25mm (0.98")	88mm (3.46")	8mm (0.32")
	F Mode			(0.01mil up to 5mils; 0.1mil 5-60mils)	4mm (0.16")	25mm (0.98")	88mm (3.46")	4mm (0.16")
<b>T456FNF1R</b>	N Mode	0-1500µm (0-60mils)	±1-3% or ±2.5µm (±0.1mil)	0.1µm up to 100µm; 1µm 100-1500µm	38mm (1.50")	25mm (0.98")	34mm (1.34")	8mm (0.32")
	F Mode			(0.01mil up to 5mils; 0.1mil 5-60mils)	4mm (0.16")	25mm (0.98")	34mm (1.34")	4mm (0.16")
<b>T456FNF1P</b>	PINIP™ N Mode	0-1500µm (0-60mils)	±1-3% or ±2.5µm (±0.1mil)	0.1µm up to 100µm; 1µm 100-1500µm	38mm (1.50")	55mm (2.17")	156mm (6.15")	8mm (0.32")
	PINIP™ F Mode			(0.01mil up to 5mils; 0.1mil 5-60mils)	4mm (0.16")	55mm (2.17")	156mm (6.15")	4mm (0.16")

## Elcometer 456 Probe Accessories



### JUMBO HAND GRIP

Ideal for precision placement for the most accurate results on flat and curved surfaces. Place the probe inside the Jumbo Hand Grip and take measurements - ideal when wearing gloves.

T9997766- Jumbo Hand Grip - F and N Probes

T99913225 Jumbo Hand Grip - FNF Probe

Use with the following Elcometer 456 Probes:  
F1 Standard, F12 Standard, N1 Standard, FNF Standard



### V-PROBE ADAPTOR

Ideal for precision placement for the most accurate results on medium and large diameter curved surfaces such as pipes and cylinders.

T9997381- V-Probe Adaptor - F and N Probes

T99913133 V-Probe Adaptor - FNF Probe

Use with the following Elcometer 456 Probes:  
F1 Standard, F12 Standard, N1 Standard, FNF Standard



### SOFT MATERIAL/BLANKET PROBE

Ideal for taking precision readings on soft coatings or printing blankets. The wide, flat base design acts as a load spreader, reducing the total force at a single point.

T456F2B Soft Material/Blanket Probe for Elcometer 456



### PROBE PLACEMENT JIG

For the most reliable and repeatable coating thickness measurements, making the gauge score highly in repeatability and reproducibility studies. Ideal for small and large components alike. The probe placement jig is supplied with a probe housing to suit standard F1, F12 and N1 probes. Housings to suit other probes are available as optional accessories.

T95012880 Probe Placement Jig

T95013028 Component Hand Vice - a simple vice to hold small components

T95012888 Cable Release Assembly - ideal for remote measurements

T95015961 Adaptor for FNF Probes

T95016896 Adaptor Kit for Miniature Probes - includes special adaptor for 45mm Straight Probes

Use with the following probes:  
F1 Standard, F12 Standard, N1 Standard, FNF Standard and all Miniature Probes

A comprehensive range of both nominal and certified foils together with zero test plates is available to ensure the accuracy of the gauges. See pages 208 - 210 for full details.

## ElcoMaster™ Data Management Software

Supplied free of charge with Elcometer 456\* and Elcometer 355 gauges, ElcoMaster™ makes it easy to collate and use the data recorded.

Whether the data is to be used for analysis, to create professional reports for distribution, print reports or to archive for future use, ElcoMaster™ can help. With inbuilt report templates and easy access to all data, images and other associated files, ElcoMaster™ makes managing data simple.

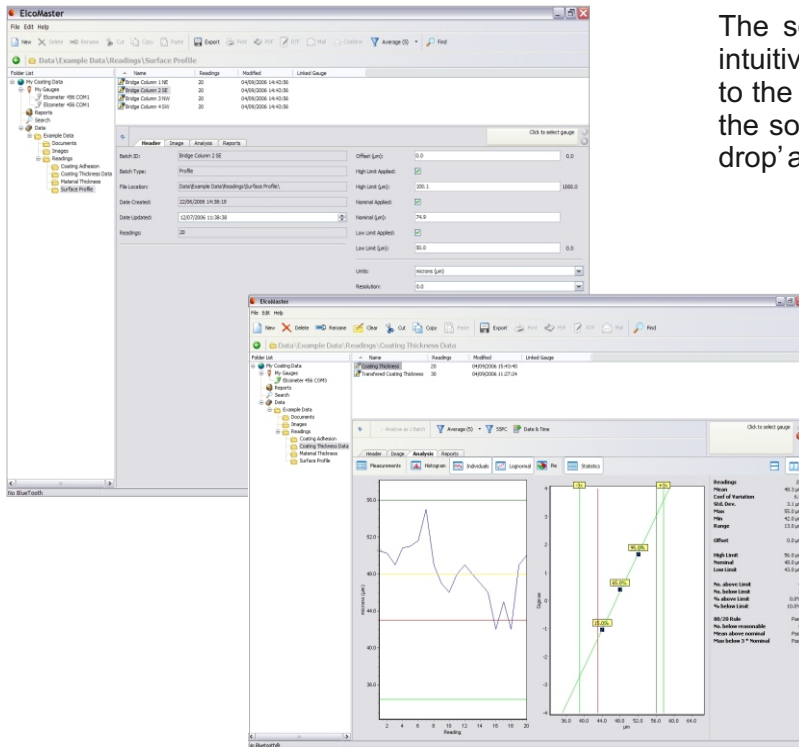

The software has been designed to be familiar and intuitive to any PC user. When the gauge is connected to the PC, individual readings can be sent directly into the software for real time analysis or simply 'drag and drop' a batch from the gauge to the software.

You can store all of your associated job or inspection files, health and safety reports etc. within ElcoMaster™ one programme holds all of your inspection information in one place. Data can also be transferred directly from the gauge to a PDA or mobile phone for instant reporting in the field, using ElcoMaster™ Mobile.\*\*

Viewing data and producing standard reports is achievable in just a few clicks. Fully customised reports can be produced quickly by using the ElcoMaster™ Report Designer.

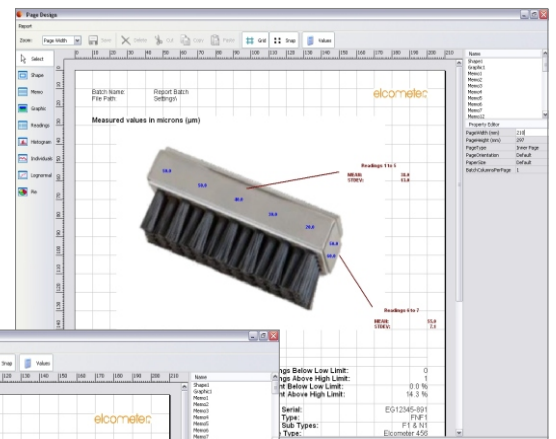

In addition to the readings and charts, you can also assign a digital photograph or drawing to an individual batch of data, allowing you to visually display the inspection area in your reports. Values can be stored on templates as can averages and statistics in certain zones, e.g. car doors. Batches can be combined for immediate comparison of data from various areas of the job site.

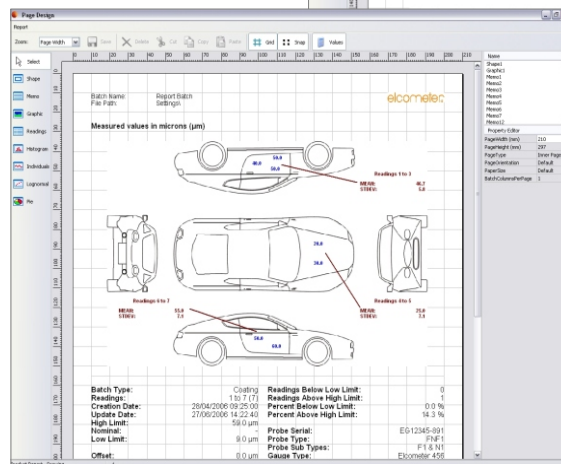

\* Supplied with Standard and Top Models only. Free software upgrades available via the website  
\*\* ElcoMaster™ Mobile compatible with Windows Mobile 5 or Windows Mobile 6 Professional or later..

## ElcoMaster™ Data Management Software

ElcoMaster™ features:

- Create professional reports in seconds
- Export reports to spreadsheets, text files or save as PDF or JPEG files
- Copy and paste reports into other documents
- Reports can be combined in order to clearly compare different batches
- E-mail reports directly from ElcoMaster™ or ElcoMaster™ Mobile\*\* for ultimate flexibility
- Assign batch identification tags
- Batches can be renamed to clearly identify the area inspected or job name
- Combine batches to compare readings or link batches together from different gauges into one comprehensive inspection file
- 'Find' feature quickly locates a specific file or batch
- Supports gauges with *Bluetooth*® wireless technology

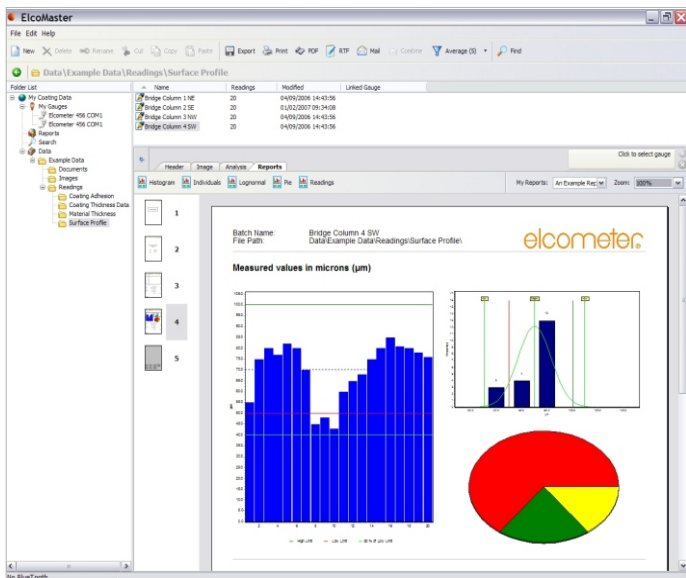
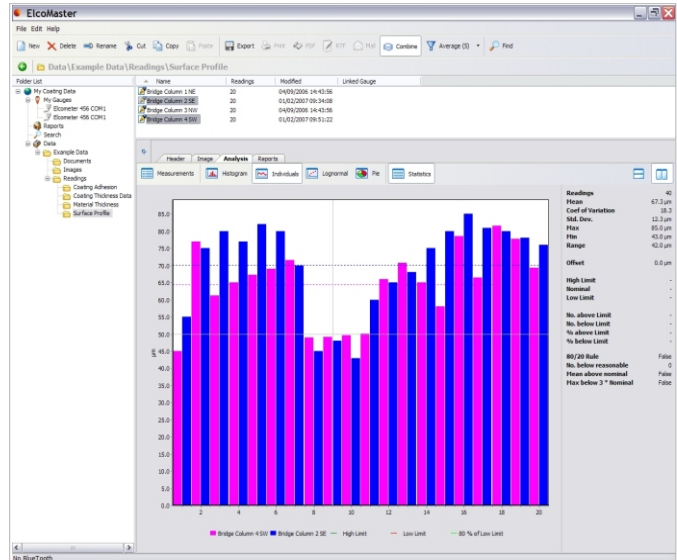

- The wide range of standard reports includes;
  - Individual measurements
  - Statistics
  - Histograms
  - Individual line or bar charts
  - Log normal
  - Pie charts
- Fully customise reports using the ElcoMaster™ Report Designer tool
- Include company graphics and logos in every report

ElcoMaster™ is the ultimate digital job file software™ solution. It allows users to store all their readings for coatings including dry film thickness, adhesion, cleanliness, climate, surface profile etc. and links to many Elcometer product groups. This ensures full details of the entire coatings process are easy to compare and monitor, resulting in less waste, better accuracy and lower costs.

## Elcometer 355 Coating Thickness Gauge

The Elcometer 355's watchwords are accuracy, simplicity, versatility and durability making this a true state of the art hand held measuring system packed with time-saving and cost-cutting features.

Available as a standard and top model, the unit's large memory stores up to 10,000 readings in batches and data can be output to PC, datalogger or printer as required.

With a comprehensive range of Probe Modules available, simply select the most appropriate for the application. All modules are supplied with calibration foils.

- $\pm 1\%$  or  $1\mu\text{m}$ , whichever is the greater, accuracy
- Rugged aluminium case designed for the toughest environments
- ElcoMaster™ software supplied (see pages 200 - 201)
- Full statistical analysis - mean standard deviation, number of readings, highest and lowest value
- RS232 output
- Date and time stamp

Each gauge is supplied without a probe allowing the choice of the correct probe for the relevant applications.

For a full list of probes and accessories, see pages 203 - 204.



### Technical Specification

**T** certificate available

Part Number	Description
A355----S	Elcometer 355 Standard Coating Thickness Gauge
A355----T	Elcometer 355 Top Coating Thickness Gauge
Operating Temperature	0°C to 50°C (32°F to 120°F)
Storage Temperature	-10°C to 60°C (14°F to 140°F)
Dimensions	175 x 83 x 42mm (6.9 x 3.3 x 1.6")
Weight	650g (1.43lb)
Reading Speed	40 readings per minute
Data Output	RS232C Serial or Parallel Output via D25 Type Connector (Female)
Memory	Standard: 5,000 reading memory in 25 pre-set batches Top: 10,000 reading memory in up to 200 batches (individually calibrated)
Battery Type	3 x 1.5V AA Cells (Alkaline) or 3 x 1.5V Nickel Metal Hydride rechargeable cells
Battery Life	Minimum: 40 hours with alkaline batteries, 20 hours with rechargeable batteries
Packing List	Elcometer 355 Top or Standard Gauge, leather carry case, 3 x AA batteries, ElcoMaster™ software, PC cable and operating instructions

Can be used in accordance with: (see Standards Explained inside Front Cover)

AS 2331.1.4, AS 3894.3-B, ASTM B 499, ASTM D 1186-B, ASTM D 1400, ASTM D 7091, ASTM E 376, ASTM G 12, AS/NZS 1580.108.1, BS 3900-C5, BS 3900-C5-6Aa, BS 5411-11, BS 5599, DIN 50981, ECCA T1, EN 13523-1, IMO MSC.215(82), ISO 1461, ISO 2063, ISO 2360, ISO 2808-5, ISO 2808-7C, ISO 2808-7D, ISO 19840, NF T30-124, SSPC PA 2, US Navy NSI 009-32, US Navy PPI 63101-000, SS 184160

## Elcometer 355 Ferrous and Non-Ferrous Probes

Unique probe modules allow the Elcometer 355 Coating Thickness Gauges to be versatile and flexible for any measurement application.

Probe modules can be freely interchanged as required for both ferrous (F) and non-ferrous (N) metal substrates.

Most probe modules are capable of an accuracy of  $\pm 1\%$  of the reading on a variety of coatings and surfaces.

Telescopic probes extend from 410mm (16") to 1100mm (43").



### Technical Specification

Part Number	Description	Measuring Range	Accuracy	Resolution	Range Steps	
T35511952	F1 Standard					
T35511953	F1 Right Angle		0-1500 $\mu$ m (0 - 60mils)	$\pm 1\%$ or $\pm 1\mu$ m ( $\pm 0.04$ mil)	0-200 $\mu$ m (0-8mils) 200-500 $\mu$ m (8-20mils) 500-1500 $\mu$ m (20-60mils)	
T35511959	F1 Telescopic					0.1 $\mu$ m (0.005mil) 0.5 $\mu$ m (0.02mil) 1.0 $\mu$ m (0.05mil)
T35512400	F1A (Automotive)					
T35511954	F2 Standard					
T35511955	F2 Right Angle		0-5mm (0-200mils)	$\pm 1\%$ or $\pm 5\mu$ m ( $\pm 0.2$ mil)	0-500 $\mu$ m (0-20mils) 500-5000 $\mu$ m (20-200mils)	
T35511960	F2 Telescopic					2 $\mu$ m (0.1mil) 5 $\mu$ m (0.2mil)
T35511956	F3 Standard		0-13mm (0-500mils)	$\pm 2\%$ or $\pm 30\mu$ m ( $\pm 1$ mil)	0-1000 $\mu$ m (0-40mils) 1-13000 $\mu$ m (40-1500mils)	5 $\mu$ m (0.2mil) 10 $\mu$ m (0.5mil)
T35511950	F4 Standard		0-250 $\mu$ m (0-10mils)	$\pm 1\%$ or $\pm 1\mu$ m ( $\pm 0.04$ mil)	0-250 $\mu$ m (0-10mils)	0.1 $\mu$ m (0.005mil)
T35511951	F4 Right Angle					
T35511962	F5 (Rebar)		0-800 $\mu$ m (0-32mils)	$\pm 1\%$ or $\pm 2\mu$ m ( $\pm 0.08$ mil)	0-800 $\mu$ m (0-32mils)	1 $\mu$ m (0.1mil)
T35511964	F6 Standard		0-25mm (0-1000mil)	$\pm 2\%$ or $\pm 100\mu$ m ( $\pm 4$ mils)	0-500 $\mu$ m (0-200mils) 5000-25000 $\mu$ m (200-1000mils)	10 $\mu$ m (0.5mil) 50 $\mu$ m (2mil)
T35511982	N1 Standard		0-1500 (0-60mils)	$\pm 1\%$ or $\pm 1\mu$ m ( $\pm 0.04$ mil)	0-200 $\mu$ m (0-8mils) 200-500 $\mu$ m (8-20mils) 500-1500 $\mu$ m (20-60mils)	
T35511983	N1 Right Angle					0.1 $\mu$ m (0.005mil) 0.5 $\mu$ m (0.02mil) 1.0 $\mu$ m (0.05mil)
T35511984	N2 Standard					
T35511980	N4 (Anodisers)		0-250 $\mu$ m (0-10mils)	$\pm 1\%$ or $\pm 1\mu$ m ( $\pm 0.04$ mil)	0-250 $\mu$ m (0-10mils)	0.1 $\mu$ m (0.005mil)

## Elcometer 355 Probe Accessories



### JUMBO HAND GRIP

Ideal for precision placement for the most accurate results on flat and curved surfaces. Place the probe inside the Jumbo Hand Grip and take measurements - ideal when wearing gloves.

**T9997766-** Jumbo Hand Grip - F and N Probes

Use with the following Elcometer 355 probes:  
F1 Standard, F2 Standard, F4 Standard, F5 Rebar, N1 Standard



### V-PROBE ADAPTOR

Ideal for precision placement for the most accurate results on medium and large diameter curved surfaces such as pipes and cylinders.

**T9997381-** V-Probe Adaptor - F and N Probes

Use with the following Elcometer 355 probes:  
F1 Standard, F2 Standard, F4 Standard, F5 Rebar, N1 Standard



### SOFT MATERIAL/BLANKET PROBE

Ideal for taking precision readings on soft coatings or printing blankets. The wide, flat base design acts as a load spreader, reducing the total force at a single point.

**T35511963** Soft Material/Blanket Probe for Elcometer 355



### PROBE PLACEMENT JIG

For the most reliable and repeatable coating thickness measurements, making the gauge score highly in repeatability and reproducibility studies. Ideal for small and large components alike. The probe placement jig is supplied with a probe housing to suit standard F1, F2, F4, F5 and N1 probes. Housings to suit other probes are available as optional accessories.

**T95012880** Probe Placement Jig

**T95013028** Component Hand Vice - a simple vice to hold small components

**T95012888** Cable Release Assembly - ideal for remote measurements

**T95015589** N4 Probe Adaptor - must be purchased for use with N4 Probes

Use with the following probes:

F1 Standard, F2 Standard, F4 Standard, F5 Rebar, N1 Standard and N4 Standard

A comprehensive range of both nominal and certified foils together with zero test plates is available to ensure the accuracy of the gauges. Please see pages 208 - 210 for full details.



## Elcometer 101 Coating Thickness Gauge

The original non - destructive dry film thickness gauge, the Elcometer 101 was the world's first portable coating thickness gauge with the original being produced in 1947.

- Insensitive to hot and cold surfaces - ideal for hot sprayed metal coatings
- Incorporates reading hold feature
- Accuracy of  $\pm 10\%$
- Ideal for hazardous areas



### Technical Specification

**C** certificate available

Part Number	Description	Range
A101A-05A	Elcometer 101 Mechanical Coating Thickness Gauge	0 - 250 $\mu$ m (0 - 10mils)
A101A-01A	Elcometer 101 Mechanical Coating Thickness Gauge	0 - 600 $\mu$ m (0 - 25mils)
Operating Plane	90° to substrate	
Minimum Measurement Area	38 x 15mm (1.5 x 0.6")	
Minimum Measurement Diameter	25mm (1") (on bar material)	
Accuracy	$\pm 10\%$ of the reading or 2.5 $\mu$ m (0.1mil) which ever is the greater	
Packing List	Elcometer 101, calibration foils, carry case, wrist harness and operating instructions	

Can be used in accordance with: (see Standards Explained inside Front Cover)

AS 2331.1.3, ASTM B 499, ASTM D 1186-B, ASTM G 12, BS 5411-11, ISO 2178, SSPC PA2

## Elcometer 157 Coating Thickness Gauge

This simple, pull-off gauge is a top-pocket, lightweight, foreman's type gauge for spot check indications of coating thicknesses.

- Insensitive to hot and cold coatings or surfaces - ideal for hot sprayed metal coatings for immediate results
- Easy to use and lightweight
- 3 scales on the instrument body: mils, microns and linear
- Pre-calibrated with no adjustment required



### Technical Specification

Part Number	Description
A157----A	Elcometer 157 Coating Thickness Gauge
Ranges	Three scales printed on the body: 0 - 600 $\mu$ m, 0 - 25mils, linear (0 - 10 equally spaced divisions)
Accuracy	$\pm 15\%$ of the reading
Packing List	Elcometer 157, protective case, graph card and operating instructions

## Elcometer 211 Coating Thickness Gauge

The Elcometer 211, commonly referred to as the “Banana Gauge”, has proven to be a successful coating thickness gauge where the use of electronic instruments is difficult, e.g. inflammable atmospheres in oil and gas production.

The “V” grooved base, rubber feet and clear scale, with its ranges for thicker coatings, make this one of the most popular mechanical gauges in the world.

- Factory calibrated - with user calibration adjustment
- Foils supplied to check calibration on site
- Ideal for cold surfaces and underwater use
- Small and portable with an accuracy  $\pm 5\%$



### Technical Specification

certificate available

Part Number	Description	Range
A211F--1M	Elcometer 211 Coating Thickness Gauge	0 - 1000 $\mu$ m
A211F--8M	Elcometer 211 Coating Thickness Gauge	0.65 - 6mm
A211F--1E	Elcometer 211 Coating Thickness Gauge	0 - 40mils
A211F--8E	Elcometer 211 Coating Thickness Gauge	25 - 250mils
Accuracy	$\pm 5\%$ of the reading or $\pm 2.5\mu\text{m}/0.1\text{mil}$ (whichever is the greater)	
Substrate Thickness	0.4mm (16mils) minimum	
Measurement Area	30mm (1.18") Diameter minimum	
Measurement Diameter	20mm (0.8") minimum	
Edge Effects	Must be at least 6mm (0.24") from edge	
Dimensions	200 x 60 x 30mm (7.8 x 2.4 x 1.2")	
Packing List	Elcometer 211, calibration foil set, carry pouch, neck harness and operating instructions	

Can be used in accordance with: (see Standards Explained inside Front Cover)

AS 2331.1.3, AS 3894.3-A, ASTM D 1186-A, ASTM G 12, ASTM B 499, AS/NZS 1580.108.1, BS 5411-11, BS 3900-C5, DIN 50981, ISO 2178, ISO 2808-7A, SSPC-PA2

Customers who have purchased the Elcometer 211 Coating Thickness Gauge also purchased:



◀ Elcometer 456 Coating Thickness Gauge, pages 188 - 193

Elcometer Traceable Coating Standards, page 210 ▶



## Calibration Foils & Standards

Formal quality systems, such as those described in ISO 9000, ISO 17025 and Guide 25, require that gauges be properly controlled, logged and in calibration. Increasingly, users are specifying that the readings taken by gauges are traceable to National Standards. There are three types of coating thickness standards available from Elcometer: coated standards, calibration foils and zero test plates.

## Elcometer 990 Calibration Foils & Zero Test

The Elcometer 990 Calibration Foils and Zero Test plates are ideal for use in the laboratory, on the production line or on site. Calibration foils or 'shims' are the most convenient way of creating a coating thickness standard on the substrate material, surface finish or form. This is the ideal method for adjusting the calibration of the coating thickness gauge to ensure the greatest possible accuracy.

In some cases, it may be difficult or impractical to obtain an uncoated substrate. For this reason Elcometer provides a range of Zero Test Plates. These Test Plates, when used in conjunction with a set of foils, are ideal to test a coating thickness gauge's functionality and calibration.

Features:

- Metric and Imperial values displayed on each foil
- Available individually or in foil sets - with or without Zero Plate
- Available as either a precision foil ( $\pm 1\%$  accuracy) or as a nominal foil ( $\pm 2\%$  accuracy)
- Each foil has unique serial number for traceability
- Available in thicknesses from 12.5 $\mu\text{m}$  to 20mm (0.5 to 790mils)

For a list of standards, foils and foil sets, see pages 208 - 210.



### Technical Specification

**C,A** certificate available

Part Number	Description	Part Number	Description
T3459529-	2% Ferrous Zero Test Plate	T3459530-	2% Non Ferrous Zero Test Plate
T3554910-	1% Ferrous Zero Test Plate	T3554911-	1% Non Ferrous Zero Test Plate
T9994054-	Large Ferrous Zero Test Plate	T9994055-	Large Non Ferrous Zero Test Plate

### Using calibration foils



- ◀ Each foil has been independently measured at the centre point  
For the greatest accuracy, place the probe in the centre of the foil

Up to 4 foils can be combined to create a wider range of thickness values. ▶



## Individual Nominal Foils

Technical Specification			C,A certificate available	
Part Number	Colour	Values* (µm)	Values* (mils)	
T9904169-	Silver	12.5	0.5	
T9904170-	Purple	25	1.0	
T9904171-	Dark Blue	50	2.0	
T99011411	Green	75	3.0	
T9904172-	Brown	125	5.0	
T9904173-	Peacock Blue	175	7.0	
T9904174-	White	250	10	
T9904175-	Black	500	20	
T9904191-	Grey/Blue	1020	40	
T9904190-	Clear	2000	80	
T9904180-	Clear	3000	120	
T9904181-	Clear	4000	160	
T99011674	Slate	8000	315	
T45618978-2	Grey <sup>†</sup>	1500	59	
T45618978-3	Grey <sup>†</sup>	5000	197	



Nominal foils have a  $\pm 2\%$  accuracy

<sup>†</sup>For use with the high temperature PINIP<sup>™</sup> probes only due to the potential high temperature of the sample. Foils supplied in a cap which fits over the PINIP<sup>™</sup> probe.

## Nominal Foil Sets

Technical Specification			C,A certificate available	
Part Number	Description	Values* (µm)	Values* (mils)	
T9904199S	Scale 1	50, 125, 500, 1020	2.0, 5.0, 20, 40	
T99041991	Scale 1	50, 125, 250, 500, 1020	2.0, 5.0, 10, 20, 40	
T9904199E	Scale 1	12, 25, 50, 125, 250, 500, 1020	0.5, 1.0, 2.0, 5.0, 10, 20, 40	
T9904199F	Scale 1	12, 25, 50, 125, 175, 250, 500, 1020	0.5, 1.0, 2.0, 5.0, 7.0, 10, 20, 40	
T9904199J	Scale 2	500, 1020, 2000, 2000	20, 40, 80, 80	
T99041992	Scale 2	50, 125, 250, 500, 1020, 1020, 3000, 4000	2.0, 5.0, 10, 20, 40, 40, 120, 160	
T9904199K	Scale 3	1000, 2000, 4000, 8000	40, 80, 160, 315	
T99041995	Scale 4	12, 25, 50, 125, 175	0.5, 1.0, 2.0, 5.0, 7.0	
T99041990	Scale 4	12, 25, 50, 125, 175, 250	0.5, 1.0, 2.0, 5.0, 5.0, 7.0, 10	
T99041994	Scale 5	12, 25, 50, 125, 250, 500	0.5, 1.0, 2.0, 5.0, 10, 20	
T99041993	Scale 6	1000, 1000, 5000, 5000, 12000, 20000	40, 40, 200, 200, 475, 790	

Nominal foil sets have an accuracy of  $\pm 2\%$

\*Actual foil values may vary, but are accurately labelled.

**Certified Precision Foils**

Technical Specification C,A certificate available

Part Number	Colour	Values* (µm)	Values* (mils)
T990490101	Silver	12.5	0.5
T990490102	Purple	25	1.0
T990490103	Dark Blue	50	2.0
T990490104	Green	75	3.0
T990490105	Brown	125	5.0
T990490106	Peacock Blue	175	7.0
T990490107	White	250	10
T990490108	Black	500	20
T990490109	Clear	1000	40
T990490110	Off White	1500	60
T990490111	Clear	2000	80
T990490112	Clear	3000	120
T990490113	Clear	4000	160
T990490114	Slate	8000	315



Certified precision foils have a ±1% accuracy

Foils can be combined to make a bespoke set. A calibration certificate is supplied with any combination of up to eight foils.

**Certified Precision Foil Sets**

Technical Specification C,A certificate available

Part Number	Scale Range	Values* (µm)	Values* (mils)
T99049001	Scale F1	12.5, 25, 50, 125, 250, 500, 1000, 1500	0.5, 1.0, 2.0, 5.0, 10, 20, 40, 60
T99049002	Scale N1	12.5, 25, 50, 125, 250, 500, 1000, 1500	0.5, 1.0, 2.0, 5.0, 10, 20, 40, 60
T99049003	Scale F2	50, 125, 250, 500, 1000, 2000, 4000	2.0, 5.0, 10, 20, 40, 80, 160
T99049007	Scale N2	50, 125, 250, 500, 1000, 2000, 4000	2.0, 5.0, 10, 20, 40, 80, 160
T99049004	Scale F3	500, 1000, 2000, 3000, 4000, 8000	20, 40, 80, 120, 160, 315
T99049005	Scale F4	12.5, 25, 50, 75, 125, 175, 250	0.5, 1.0, 2.0, 3.0, 5.0, 7.0, 10
T99049008	Scale N4	12.5, 25, 50, 75, 125, 175, 250	0.5, 1.0, 2.0, 3.0, 5.0, 7.0, 10

Certified precision foils have a ±1% accuracy and are supplied with ferrous or non ferrous zero test plates & calibration certificate.

Additional foils are available covering the range 8mm to 20mm (315mils to 790mils). Please contact Elcometer for further information.

Foils below 50µm (2.0mils) have an accuracy of ±0.5µm (0.02mil).

\*Actual foil values may vary, but are accurately labelled. Foil values have an accuracy of ± 2%

## Elcometer 995 Coated Thickness Standards

The Elcometer 995 Coated Thickness Standards are hard wearing, durable and are mounted in a protective folder.

They provide the user with an ideal method to accurately measure the performance of the coating thickness gauge.

### Features:

- $\pm 2\%$  accuracy, supplied with Calibration Certificate as standard
- Available with either Ferrous (F) or Non-Ferrous (N) substrates
- Each standard is individually serial numbered for traceability
- Can be re-certified by Elcometer to meet ISO requirements
- Standards available in a range of thicknesses
- Special thicknesses can be supplied to meet specific needs
- Coated with a hard wearing film for extended life span



### Technical Specification

certificate available

Part Number	Description	Values ( $\mu\text{m}$ )	Values (mils)
T995111262	4 Piece Thickness Standards - Ferrous	Zero, 40, 75, 125, 175	Zero, 1.6, 3.0, 5.0, 7.0
T995111271	4 Piece Thickness Standards - Non Ferrous	Zero, 40, 75, 125, 175	Zero, 1.6, 3.0, 5.0, 7.0
T995111263	4 Piece Thickness Standards - Ferrous	Zero, 50, 80, 125, 200	Zero, 2.0, 3.0, 5.0, 8.0
T995111261	4 Piece Thickness Standards - Ferrous	Zero, 50, 150, 250, 500	Zero, 2.0, 6.0, 10, 20

## Elcometer 195 Säberg Drill

For some coating/substrate combinations it is necessary to use a destructive method.

A Paint Inspection Gauge (PIG) makes a linear cut along the coating, whereas the Elcometer 195 Säberg Drill makes a small conical hole in order to measure the coating thickness layer, ideal for minimal damage to your coating.

- Ideal for hard or brittle coatings
- Measures coatings up to 1600µm (63mils) with x50 microscope (included)



### Technical Specification

**C,A** certificate available

Part Number	Description
A195---1A	Elcometer 195 Säberg Drill
Packing List	Elcometer 195 Säberg Drill, drill block, steel cutter holder, aluminium cutter holder, x50 microscope, 2 x cutting drills, instruction card and carry case

Can be used in accordance with: (see Standards Explained inside Front Cover)

AS 2331.1.7, ASTM D 4138-C

### Accessories

T1955188-	Spare 90° Drill
-----------	-----------------

### Using the Säberg Drill

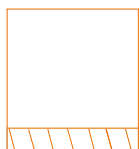

1. Take the uncoated product.

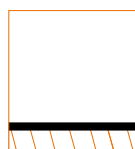

2. Apply the coating or coating system to the surface.

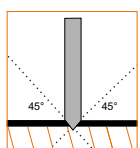

3. Use the Säberg drill to create a 45° angle conical hole in the coating

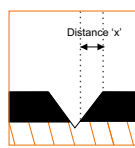

4. Use the microscope to calculate the distance 'x' which will be equal to the coating thickness.

## Elcometer 141 Paint Inspection Gauge

The Elcometer 141 PIG is a quick, versatile method of examination and destructive measurement of coatings in a portable, easy to use instrument.

Ergonomically designed to give a balanced weight distribution for a consistent cut, it is ideal for tough coatings and enamels.

- Large easy grip handle - makes cutting thick or hard coatings easy
- Internal cutter storage compartment
- x50 magnification microscope



### Technical Specification

**C,A** certificate available

	Metric	Imperial
Part Number	<b>A141---M</b>	<b>A141---E</b>
Scale Range (maximum)	2mm	0.08"
Dimensions (fitted to handle)	160 x 100 x 35mm	6.3 x 4 x 1.4"
Weight (fitted to handle)	510g	1lb 2oz
Packing List	Elcometer 141 P.I.G, x50 microscope with Metric or Imperial scale, 3 cutters, marker pen, hexagonal wrench, carry case, operating instructions	

*Can be used in accordance with: (see Standards Explained inside Front Cover)*

**AS 1580.108.2, ASTM D 4138, BS EN 3900-CS-5B, DIN 50986, ISO 2808-5B**

### Accessories

Part Number	Part Number	Cutting Angle	Measurement Range	Graticule Scale Factor
<b>T14115761-1</b>	Tungsten Carbide Cutter No 1	45°	20 - 2000µm (1 - 80mils)	20µm (1mil)
<b>T14115761-4</b>	Tungsten Carbide Cutter No 4	26.6°	10 - 1000µm (0.5 - 35mils)	10µm (0.5mil)
<b>T14115761-6</b>	Tungsten Carbide Cutter No 6	5.7°	2 - 200µm (0.1 - 8mils)	2µm (0.1mil)

### Using the Paint Inspection Gauge



1. Take the coated product.

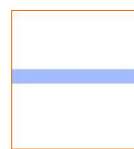

2. Using the supplied marker, draw a line across the coating.



3. Using the P.I.G, make a cut at right angles to the marker line, all the way down to the substrate.

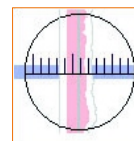

4. Use the supplied microscope to count the number of graticule divisions across a coating layer & calculate the thickness value using the graticule scale factor.



## Elcometer 121/3 Universal Paint Inspection Gauge

The Elcometer 121/3 Universal PIG provides a quick, versatile method of coating examination and destructive measurement of coating thickness and cross hatch adhesion in a portable, easy to use gauge.

The gauge can be used on single or multiple coats on virtually all substrates including wood, plastic and metal. A bright white LED ensures clear vision through the integrated x50 microscope with integrated graticule scale.

- Compact and convenient
- Holds three knife sizes and one cross cut knife
- Small in size to facilitate use in confined areas
- Simple rotation of the cutter holder to change the cutting tool
- Made of anodised aluminium for durability
- Bright LED light source for clear vision



### Technical Specification

**C,A** certificate available

Part Number	Description
<b>A121----3</b>	Elcometer 121/3 Paint Inspection Gauge with Cutters No. 1, 2 and 3 and integral x50 magnification
<b>A121----3C</b>	As A121----3 with calibration certificate for each cutter
Range	2 - 2000µm (0.08 - 80mils)
Accuracy	Depends upon tool cut angle, half a division
Body Material	Anodised aluminium
Dimençons	110 x 60 x 25mm (4.3 x 2.3 x 1")
Packing List	Elcometer 121/3 Universal PIG 1, 2 and 3 cutters, 3.0mm hexagonal wrench, black marker pen, wrist strap, leather carry case, operating instructions

*Can be used in accordance with: (see Standards Explained inside Front Cover)*

**AS 1580.108.2, AS 1580.408.4, AS 3894.9, ASTM D 3359-B, ASTM D 4138-A, BS 3900-C5, BS 3900-E6, DIN 50986, ECCA T6, EN 13523-6, ISO 2409, ISO 2808-5B, ISO 2808-6B, ISO 16276-2**

### Accessories

**C,A** certificate available

<b>T12120256-1</b>	Cutter 1: 20 - 2000µm (0.8 - 80mils)*
<b>T12120256-2</b>	Cutter 2: 10 - 1000µm (0.4 - 40mils)*
<b>T12120256-3</b>	Cutter 3: 5 - 600µm (0.2 - 24mils)*
<b>T12120256-4</b>	Cutter 4: 2 - 250µm (0.08 - 10mils)*
<b>T12120256-5</b>	Cross Hatch Cutter 1mm (ISO)*
<b>T12120256-6</b>	Cross Hatch Cutter 2mm (ISO)*
<b>T12120256-7</b>	Cross Hatch Cutter 3mm (ISO)*
<b>T12120256-8</b>	Cross Hatch Cutter 1mm (ASTM)*
<b>T12120256-9</b>	Cross Hatch Cutter 1.5mm*
<b>T12120201</b>	Black Marker Pen
<b>T1212594-</b>	Allen Key (3mm)

\* add C to the end of the part number for calibration certificate

## Elcometer 126 and 3240 Dry and Wet Film Gauges

The Elcometer 126 (shown) and Elcometer 3240 are easy to use gauges and designed to measure the thickness of a coating.

**Dry Film:** The measurement of the difference in height between the surface of the coating and the bare surface of the substrate, given by 2 fixed resting points (or outer foot) and a central mobile sensor, indicates the thickness of the dry film.

**Wet Film:** A knurled screw is situated on the upper part of the gauge and enables the travel of the probe to be varied over a height of 500µm (20mils) until it touches the film. The difference between the resting points on the substrate and the probes indicates the film thickness.



### Technical Specification

**C,A** certificate available

Part Number	Description	Display	Graduation	Range
E126B--M-	Elcometer 126 Thickness Gauge Metric	Dial	10µm	0 - 1000µm
E126B--E-	Elcometer 126 Thickness Gauge Imperial	Dial	0.4mil	0 - 50mils
K0003240M003	Elcometer 3240 Thickness Gauge	Dial	1µm	0 - 5000µm
K0003240M006	Elcometer 3240 Thickness Gauge with Data Output	Digital	1µm	0 - 5000µm
Packing Lists	Elcometer 126: Metric or Imperial gauge, glass slide, case and operating instructions Elcometer 3240: Gauge, battery (digital gauge only), soft storage case and operating instructions			

Can be used in accordance with: (see Standards Explained inside Front Cover)

BS 3900-C5-3, ISO 2808-4B, ISO 2808-5B, NF T30-122

### How to use a Wet and Dry Gauge.

#### Wet Film:

Place the instrument on the coated substrate, the legs resting on the substrate, and simply take the measurement from substrate to the top of the wet film, measured by a knurled screw and displayed on the face of the gauge.

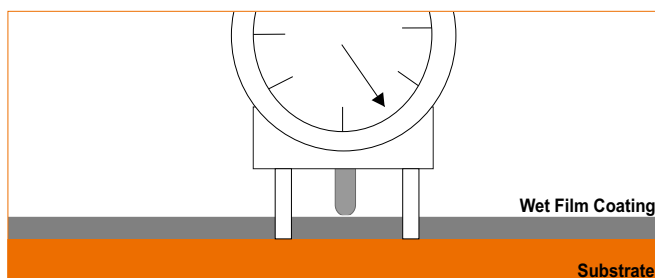

#### Dry Film:

Remove a small area of the coating to reveal the substrate and place the instrument above that area. The outer legs will rest on the coating surface and the central sensor is adjusted to touch the substrate. The coating thickness is displayed on the face of the gauge.

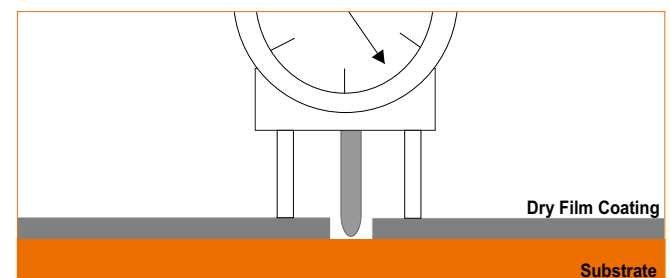

## Adhesion

From the largest man-made structures to the smallest household appliances, most manufactured products have a protective or cosmetic coating. Premature failure of this coating can, at the very least, result in additional costs of rework.

Adhesion testing after the coating process will quantify the strength of the bond between substrate and coating, or between different coating layers or the cohesive strength of some substrates. Routine testing is used as part of inspection and maintenance procedures to help detect potential coating failures.



## Adhesion Methods

### ▪ **Cross Hatch/Cross Cut Method:**

A fast, low cost, visual comparison method for paint and powder coatings up to a thickness of 250µm (10mils)

The coating is cut into small squares, thereby reducing lateral bonding, and the adhesion assessed against ISO, ASTM or Corporate Standards.



### ▪ **Pull Off Adhesion Method:**

Simple to use, quantitative range giving a definitive adhesion value, ideal for the laboratory or field on flat or curved substrate applications. Tensile Dollies (or stubs) are glued to the coating and, when the adhesive has cured, the force required to pull the coating off the surface is measured.



### ▪ **Push Off Adhesion Method:**

A dolly is adhered to the coating. When the adhesive has cured, the dolly is pushed off the surface by the adhesion tester. The push-off design makes this method ideal for flat and curved surfaces

*When selecting an adhesion gauge, it is important to use the same inspection test methods throughout the inspection to ensure accurate comparisons.*

## Classification of Cross Hatch Test Results

Surface	Typical description of result	ISO	ASTM
	The edges of the cuts are completely smooth, none of the squares of the lattice is detached.	0	5B
	Detachment of small flakes of the coating at the intersections of the cuts. A cross cut area not significantly greater than 5%, is affected.	1	4B
	The coating has flaked along the edges and/or at the intersections of the cuts. A cross cut area significantly greater than 5%, but not significantly greater than 15%, is affected.	2	3B
	The coating has flaked along the edges of the cuts partly or wholly in large ribbons, and or it has flaked partly or wholly on different parts of the squares. A cross cut area significantly greater than 15%, but not significantly greater than 35%, is affected.	3	2B
	The coating has flaked along the edges of the cuts in large ribbons and/or some squares have detached partly or wholly. A cross cut area significantly greater than 35%, but not significantly greater than 65%, is affected.	4	1B
	Any degree of flaking that cannot be classified even by classification 4 (1B).	5	0B

*Images and descriptions based on information published in ISO2409 and ASTM D 3559-B*

## Elcometer 1540 Cross Cut Tester

The Elcometer 1540 is a simple instrument for quickly determining the adhesion of a large variety of paints.

Made from steel, it has 11 tapered teeth with 1mm spacing. Two sets of lines are cut at right angles to obtain a pattern of 100 squares.

Results are determined by the above table.



### Technical Specification

**C,A** certificate available

Part Number	Description
K0001540M001	Elcometer 1540 Cross Cut Tester (11 x 1mm)

## Elcometer 107 Cross Hatch Cutter

The Elcometer 107 Cross Hatch Cutter provides an instant assessment of the quality of the bond to the substrate. Due to its rugged construction this gauge is ideal for thin, thick or tough coatings on all surfaces. An ideal field or laboratory test.

- Robust design
- Large, non slip grip
- Ideal for thin, thick or hard coatings
- A quick change, 4 sided cutter allows adhesion testing on a wide range of coating thicknesses (1mm, 1.5mm, 2mm and 3mm)



The Elcometer 107 Cross Hatch Cutter is available as a Basic or Full Kit.

### Technical Specification



Part Number	Description	Coating Thickness	
<b>F10713222-1</b>	Elcometer 107 Basic Kit (6 x 1mm)	0 - 60µm	(0 - 2.4mils)
<b>F10713348-6</b>	Elcometer 107 Full Kit with ISO Tape (6 x 1mm)	0 - 60µm	(0 - 2.4mils)
<b>F10713348-1</b>	Elcometer 107 Full Kit with ASTM Tape (6 x 1mm)	0 - 60µm	(0 - 2.4mils)
<b>F10713222-2</b>	Elcometer 107 Basic Kit (11 x 1mm)	0 - 50µm	(0 - 2.0mils)
<b>F10713348-2</b>	Elcometer 107 Full Kit with ASTM Tape (11 x 1mm)	0 - 50µm	(0 - 2.0mils)
<b>F10713222-3</b>	Elcometer 107 Basic Kit (11 x 1.5mm)	0 - 60µm	(0 - 2.4mils)
<b>F10713222-4</b>	Elcometer 107 Basic Kit (6 x 2mm)	50 - 125µm	(2.0 - 5.0mils)
<b>F10713348-9</b>	Elcometer 107 Full Kit with ISO Tape (6 x 2mm)	50 - 125µm	(2.0 - 5.0mils)
<b>F10713348-4</b>	Elcometer 107 Full Kit with ASTM Tape (6 x 2mm)	50 - 125µm	(2.0 - 5.0mils)
<b>F10713222-5</b>	Elcometer 107 Basic Kit (6 x 3mm)	125 - 250µm	(5.0 - 10mils)
Packing List	<p><i>Basic Kit:</i> Robust handle, cutter, hexagonal wrench, presentation storage case and instructions (together with Classification of Adhesion Test Results chart)</p> <p><i>Full Kit:</i> Robust handle, cutter, hexagonal wrench, instructions (together with Classification of Adhesion Test Results chart) eye glass, brush and adhesive tape (either ASTM or ISO tape), all in a plastic ABS carry case</p>		

Can be used in accordance with: (see Standards Explained inside Front Cover)

AS 3894.9, AS 1580.408.4, ASTM D 3359-B, BS 3900-E6, ECCA T6, EN 13523-6, ISO 2409, ISO 16276-2, NF T30-038

### Accessories

<b>T10713700-2</b>	Elcometer 107 Cutter (11 x 1mm)	0 - 50µm	(0 - 2.0mils)
<b>T10713700-1</b>	Elcometer 107 Cutter (6 x 1mm)	0 - 60µm	(0 - 2.4mils)
<b>T10713700-3</b>	Elcometer 107 Cutter (11 x 1.5mm)	0 - 60µm	(0 - 2.4mils)
<b>T10713700-4</b>	Elcometer 107 Cutter (6 x 2mm)	0 - 60µm	(0 - 2.4mils)
<b>T10713700-4</b>	Elcometer 107 Cutter (6 x 2mm)	50 - 125µm	(2 - 5.0mils)
<b>T10713700-4</b>	Elcometer 107 Cutter (6 x 2mm)	61 - 120µm	(2.4 - 4.7mils)
<b>T10713700-5</b>	Elcometer 107 Cutter (6 x 3mm)	125 - 250µm	(5.0 - 10mils)
<b>K0001539M001</b>	Adhesive Tape (1 roll) ASTM D 3359	<b>T1078894-</b>	Adhesive Tape (2 rolls) ASTM D 3359
<b>K0001539M002</b>	Adhesive Tape (1 roll) ISO 2409	<b>T9999358-</b>	Adhesive Tape (2 rolls) ISO 2409

## Elcometer 1542 Cross Hatch Adhesion Tester

This is a simple but effective method for determining the adhesion of coatings. The instrument is ideal for coatings on flat surfaces and is available with one of three different spacings;

- 1mm spacing - for coating thickness < 60µm (2.4mils)
- 2mm spacing - for coating thickness < 120µm (4.7mils)
- 3mm spacing - for coating thickness < 250µm (9.8mils)

Each gauge can be supplied separately or combined in a kit with a standardised brush and x10 magnifier.

- Efficient cross hatch cutter with 8 cutting faces
- Anodised aluminium handle with a wheel for stable operation, ideal for test panels
- Supplied with an adjustment gauge for accurate positioning of the cutter face



### Technical Specification

**C,A** certificate available

Part Number	Description	Coating Thickness	
K0001542M001	Elcometer 1542 Cross Hatch Adhesion Tester (6 x 1mm) <sup>1</sup>	0 - 60µm	(0 - 2.4mils)
K0001542M002	Elcometer 1542 Cross Hatch Adhesion Tester (6 x 2mm) <sup>2</sup>	50 - 125µm	(2.0 - 5.0mils)
K0001542M003	Elcometer 1542 Cross Hatch Adhesion Tester (6 x 3mm) <sup>3</sup>	61 - 120µm	(2.4 - 4.7mils)
K0001542M201	Elcometer 1542 Cross Hatch Adhesive Kit (6 x 1mm) <sup>1</sup>	0 - 60µm	(0 - 2.4mils)
K0001542M202	Elcometer 1542 Cross Hatch Adhesive Kit (6 x 2mm) <sup>2</sup>	50 - 125µm	(2.0 - 5.0mils)
K0001542M203	Elcometer 1542 Cross Hatch Adhesive Kit (6 x 3mm) <sup>3</sup>	61 - 120µm	(2.4 - 4.7mils)
K0001542M204	Elcometer 1542 Cross Cut Kit including 3 Cross Hatch Cutters <sup>2</sup>		
Weight	200g (0.44lb)		
Dimensions	150 x 25 x 35mm (6 x 1 x 1.25")		
Packing List	Cross Hatch Cutter, adjustment gauge for setting cutting blades, hexagonal wrench, brush, magnifying glass, carry case and operating instructions		

Can be used in accordance with: (see Standards Explained inside Front Cover)

AS 1580.408.4, AS 3894.9, ASTM D 3359-B, BS 3900-E6, ECCA T6, EN 13523-6, ISO 2409, ISO 16276-2, NF T30-038

### Accessories

KT001542P001	6 x 1mm Cross Hatch Blade <sup>1</sup>
KT001542P002	6 x 2mm Cross Hatch Blade <sup>2</sup>
KT001542P003	6 x 3mm Cross Hatch Blade <sup>3</sup>
KT001542F006	Adjustment Gauge
K0001542M001	ASTM D3359 Adhesive Tape (1 roll)
T1078894-	ASTM D3359 Adhesive Tape (2 rolls)
K0001542M002	ISO 2409 Adhesive Tape (1 roll)
T9999358-	ISO 2409 Adhesive Tape (2 rolls)
KT001546N001	Cross Cut DIN Brush
KT001546N002	Magnifier (x10)

<sup>1</sup> ISO Test Method

<sup>2</sup> AS, ASTM, ISO Test Methods

<sup>3</sup> ASTM, ISO Test Methods

## Elcometer 108 Hydraulic Adhesion Testers

The Elcometer 108 Hydraulic Adhesion Tester is an extremely versatile gauge which can be used for many adhesion requirements. Tests can be made on flat or curved (concave and convex) surfaces.

The Elcometer 108 is the ideal gauge for coatings on Tanks, Pipelines, etc.

- Hand-Powered and portable
- Ideal for site work
- Reusable stainless steel dollies

Elcometer Digital Adhesion Gauge features:

- Maximum hold - displays the highest value reached
- Backlit display for dark areas
- Rubber protective casing
- Switchable Metric/Imperial units.

The Elcometer 108 can be used with convex and concave dollies, making this the gauge for adhesion of coatings on all pipelines including those with small diameter, tanks and other curved surfaces. There is a wide range of curved dollies available, each designed for a specific range of curvature.



### Technical Specification

**C** certificate available

Part Number	Description		
UK 240V	EUR 220V	US 110V	
F108---1A	F108---1B	F108---1C	Elcometer 108/1 Hydraulic Adhesion Tester - Analogue Dial Gauge
F108---2A	F108---2B	F108---2C	Elcometer 108/2 Hydraulic Adhesion Tester - Digital Gauge
Dial Adhesion Gauge Range		Operating: 0 - 18MPa (0 - 2600psi)	
Dial Pressure Gauge Accuracy		±0.5MPa Metric Scale; 150PSI (Imperial Scale)	
Digital Adhesion Gauge Range		Operating: 0 - 18MPa (0 - 2600psi)	
Digital Pressure Gauge Accuracy		±1% (50PSI)	
Instrument Accuracy		±5% of reading or 0.5MPa (50psi)	
Dolly Size	Outside Diameter	19.4mm (0.76")	
	Inside Diameter	3.7mm (0.15")	
	Area	284mm <sup>2</sup> (0.44sq.inch)	
Packing List		Elcometer 108, ABS carry case, 5 flat dollies, 5 nylon plugs, M2000 quick curing adhesive, dolly cleaning tool, heating tongs	

Can be used in accordance with: (see Standards Explained inside Front Cover)  
**ASTM D 4541, ISO 16276-1, NF T30-606**

### Accessories

T99911135	M2000 Quick Curing Adhesive
T1089646-	Standard Flat Dolly 19.4mm (0.76")

Concave and convex dollies designed to meet specific curvatures are available upon request

## Elcometer 106 Pull Off Adhesion Tester

The Elcometer 106 Adhesion Tester is easy to operate and fully portable, and provides a numerical value for adhesion. Applications include paint or plasma spray on bridge decking, coatings on steel, aluminium, concrete etc.

- Supplied in a carry case - ideal for site tests
- Hand operated - no need for a power supply
- Includes a cutter for EN13144 and ISO 4624 tests

### Test Method

A test dolly is bonded to the coating using an adhesive. The 106 houses a spring arrangement which applies a lift force to the dolly as the tension is increased.

When the coating is pulled off the surface, an indicator on the scale shows the numerical value of adhesion expressed in terms of the force per unit area required to remove the dolly.

Inspection of the dolly face is required to determine the failure mode.

To increase sensitivity at low values or for uneven surfaces, a 40mm (1.52") dolly is available. When using the 40mm (1.52") dolly, divide the scale reading by 4.



### Technical Specification

certificate available

Part Number	Description	Range		
		MPa (N/mm <sup>2</sup> )	kg/cm <sup>2</sup>	psi
F106----5	Elcometer 106 Adhesion Tester - Scale 5	0 - 0.2	0 - 2	0 - 30
F106----1	Elcometer 106 Adhesion Tester - Scale 1	0 - 3.5	0 - 35	0 - 500
F106----2	Elcometer 106 Adhesion Tester - Scale 2	0 - 7.0	0 - 70	0 - 1000
F106----3	Elcometer 106 Adhesion Tester - Scale 3	0 - 15	0 - 150	0 - 2000
F106----4	Elcometer 106 Adhesion Tester - Scale 4	0 - 22	0 - 220	0 - 3200
Dimensions	Scales 1, 2, 5: 152 x 76mm (6 x 3") Scales 3 and 4: 150mm			
Dolly Diameter	20mm (0.76")			
Dolly Area	314mm <sup>2</sup> (0.49 sq inch)			
Gross weight of Kit	Scale 1, 2 and 5: 2.1kg (4.7lb)		Scale 3: 3.4kg (7.5lb)	Scale 4: 3.6kg (8.0lb)
Packing List	Elcometer 106 Pull Off Adhesion Tester, pack of 20 dollies, Araldite adhesive, base support ring, magnetic dolly clamp, dolly cutter, ratchet spanner (scale 3 & 4 only), carry case and operating instructions			

Can be used in accordance with: (see Standards Explained inside Front Cover)

ASTM D 4541, AS/NZS 1580.408.5, EN 13144, EN 24624, ISO 4624, ISO 16276-1, NF T30-606

### Accessories

T1062895-10	Spare Dollies 20mm (0.76") Diameter (Pack of 10)
T1062895-	Spare Dollies 20mm (0.76") Diameter (Pack of 100)
T1062914-	Large Dollies 40mm (1.52") Diameter (Pack of 5)
T1062915-	Large Base Ring for 40mm (1.52") Dollies
T99912906	Araldite Epoxy Adhesive
T99914009	20mm (0.76") Dolly Cutter



## Elcometer 106/6 Coatings on Concrete Adhesion Tester

The Elcometer 106/6 Adhesion Tester has been specifically designed to measure coatings on concrete.

Operating in a similar way to the regular Elcometer 106 Adhesion Tester, the Elcometer 106/6 allows for a 50mm (2") diameter dolly for testing coatings on concrete.

- Fully portable and is supplied in a carry case - ideal for site tests



### Technical Specification

**C** certificate available

Part Number	Description
<b>F106----6</b>	Elcometer 106 Coatings on Concrete Adhesion Tester - Scale 6
Range	0 - 3.5MPa (N/mm <sup>2</sup> )    0 - 500psi    Dimensions    505 x 370 x 120mm (19.9 x 14.6 x 4.7")
Packing List	Elcometer 106/6 Coatings on Concrete Adhesion Tester, 5 x 50mm (2") dollies, support ring, Araldite adhesive, ratchet spanner, carry case and operating instructions
<i>Can be used in accordance with: (see Standards Explained inside Front Cover)</i>	
<b>ASTM D 7234, BS 1881-207, DIN 1048, EN 1542, EN 12636</b>	

### Accessories

<b>T10618570</b>	Spare Dollies 50mm (2") Diameter (Pack of 5)	<b>T99912906</b>	Araldite Epoxy Adhesive
------------------	--	------------------	-------------------------

## Elcometer 109 Tensile Adhesion Tester

The Elcometer 109 Push off Tensile Adhesion Tester provides the operator with a means of carrying out a simple pass/fail test of the adhesion of the coating against a specification limit.

- Non-destructive if coating is within specification and tensile dolly breaks
- Colour coded certified tensile dollies, with a diameter of 20mm (0.8")
- Robust and lightweight



### Technical Specification

Part Number	Description	Test Element Value	Accuracy	Colour Code
<b>F109----1</b>	Elcometer 109/1 Adhesion Tester	5MPa (725psi)	±5%	Red
<b>F109----2</b>	Elcometer 109/2 Adhesion Tester	7MPa (1015psi)	±5%	Blue
<b>F109----3</b>	Elcometer 109/3 Adhesion Tester	9MPa (1304psi)	±5%	Yellow
Dimensions	150mm x 80mm (6" x 3")	Weight	1.7kg (3.75lb)	
<i>Can be used in accordance with: (see Standards Explained inside Front Cover)</i>				
<b>NORSD K M-501, NF T30-606</b>				

### Accessories

<b>T10913952</b>	5MPa (725psi) Tensile Dollies (Pack of 25)	<b>T10913954</b>	9MPa (1304psi) Tensile Dollies (Pack of 25)
<b>T10913953</b>	7MPa (1015psi) Tensile Dollies (Pack of 25)	<b>T99912906</b>	Araldite Epoxy Adhesive

## Elcometer 1910 PATHandy™ Adhesion Tester

This easy to use, lightweight hydraulic adhesion tester applies an increasing level of pull off force to a dolly adhered to the surface under test simply by turning the handle.

The special test head has self adjusting legs, which ensure that the pull off force is applied perpendicular (90°) to the substrate - even on rough or uneven surfaces.

A wide range of dolly sizes is available in order to meet specific measurement requirements from 8.2mm (0.32") to 70mm (2.76") in diameter. Depending on the size of the dolly and application, a dolly adaptor and support ring may be required. Square dollies are also available.



### Technical Specification



Part Number	Description
<b>K0001910M001</b>	Elcometer 1910 PATHandy™ Adhesion Tester
Packing List	Elcometer 1910 PATHandy™ Adhesion Tester, 6.3kN Head, crank handle driven pull mechanism, 5 x 20mm (0.79") diameter dollies, cutting tool for 20mm (0.79") diameter dollies, hydraulic cable, carry case with protective interior and calibration certificate
<i>Can be used in accordance with: (see Standards Explained inside Front Cover)</i>	
<b>ASTM D 4541, AS/NZS 1580.408.5, EN 13144, ISO 4624, ISO 16276-1</b>	

### Accessories

Part Number	Pack of 10	Pack of 100	Description <sup>a</sup>	Range	Adaptor	Support Ring
<b>KT001910P004</b>	<b>KT001910P204</b>		8.2mm (0.32") Dolly	0 - 1200MPa (17400psi)	<b>K0001910P401</b> *	<b>KT001910P108</b> *
<b>KT001910P005</b>	<b>KT001910P205</b>		14.2mm (0.56") Dolly	0 - 40MPa (5800psi)	-	<b>KT001910P109</b> *
<b>KT001910P006</b>	<b>KT001910P206</b>		20.0mm (0.79") Dolly	0 - 20MPa (2900psi)	-	<b>KT001910P110</b> *
<b>KT001910P010</b>	<b>KT001910P210</b>		28.2mm (1.11") Dolly	0 - 10MPa (1450psi)	-	<b>KT001910P111</b> *
<b>KT001910P012</b>	<b>KT001910P212</b>		50.0mm (2.00") Dolly	0 - 3.2MPa (460psi)	<b>KT001910P406</b> *	<b>KT001910P101</b> <sup>*1</sup> or <b>KT001910P102</b> <sup>*2</sup> or <b>KT001910P123</b> <sup>*3</sup>
<b>KT001910P018</b>	<b>KT001910P218</b>		70.0mm (2.76") Dolly	0 - 5MPa (725psi)	<b>KT001910P406</b> *	<b>KT001910P102</b> <sup>*2</sup> or <b>KT001910P123</b> <sup>*3</sup>
<b>KT001910P016</b>	<b>KT001910P216</b>		50x50mm (2x2") Dolly	0 - 7.85MPa (1140psi)	<b>KT001910P406</b> *	<b>KT001910P102</b> <sup>*2</sup> or <b>KT001910P123</b> <sup>*3</sup>

\* Optional    \*Required    <sup>1</sup> Standard - 50mm (1.97")    <sup>2</sup> Large - 70mm (2.76")    <sup>3</sup> Adjustable - for 50 x 50mm and 70mm dollies

<sup>a</sup> All dimensions given are the dolly diameter

## Elcometer 1940/1941 PAT™ Adhesion Testers

This portable range of hydraulic adhesion testers provides users with the ability to measure the bond strength of coatings on a wider range of substrates with the unique testing head design each gauge ensures a perpendicular (90°C) pull irrespective of the surface contours or orientation.

Each gauge has the ability to test adhesion up to a force of 40kN. Adhesion ranges of up to 120mPa (17400psi) can be achieved depending on the test head / dolly diameter combination chosen.

Each test head is fully interchangeable with the base unit allowing the gauge to meet all your adhesion requirements.

### Features:

- Portable and simple to use
- Produces comparable test results in the laboratory and on site
- Precision gauge with both MPa (N/mm<sup>2</sup>) and psi readings
- A wide range of dolly sizes are available from 8.2mm (0.32") to 70mm (2.76") diameter

For a complete range of spares, accessories and test dollies - see page 224.



### Technical Specification



Part Number	Description
K0001940M001	Elcometer 1940 PAT™ Adhesion Tester Unit with 6.3kN Test Head Scale range 6.3kN (1416lbf)
K0001941M001	Elcometer 1941/1 PAT™ Adhesion Tester Unit with 20kN Test Head Scale Range 20kN (4496lbf)
K0001941M002	Elcometer 1941/2 PAT™ Adhesion Tester Unit with 40kN Test Head Scale range 40kN (8992lbf)
Weight of Tester	1250g (45oz)
Weight in Case	11kg (24.25lb)
Dimensions	400 x 300 x 170mm (16 x 12 x 7")
Accuracy	±1% of full scale
Packing List	Elcometer 1940/1 PAT™ Adhesion Tester, 6.3kN test head, 5 x 20mm dollies, cutting tool, heating element, hydraulic cable and operating instructions
	Elcometer 1941/1 PAT™ Adhesion Tester, 20kN test head, adaptor for 50, 70 and 50 x 50mm dollies, large support ring for 50,70 and 50 x 50mm dollies, cutting tool, hydraulic cable and operating instructions
	Elcometer 1941/2 PAT™ Adhesion Tester, 40kN test head, adaptor for 50, 70 and 50 x 50mm dollies, large support ring for 50,70 and 50 x 50mm dollies, cutting tool, hydraulic cable and operating instructions

Can be used in accordance with: (see Standards Explained inside Front Cover)

ASTM D 4541, ASTM D 7234, BS 1881-20, DIN 1048, EN 1542, EN 12636, EN 13144, EN 1348 (20, 40kN only), ISO 4624

## Elcometer PAT™ Adhesion Accessories and Spares

A wide range of dolly sizes are available in order to meet your specific measurement requirements from 8.2mm (0.32") to 70mm (2.76") in diameter. The test head chosen determines both the size of dollies that can be used and the gauge's adhesion range.

Certain test head and dolly size combinations require additional adaptors and/or support rings, as indicated in the tables below. A number of dolly cutting tools are also available.

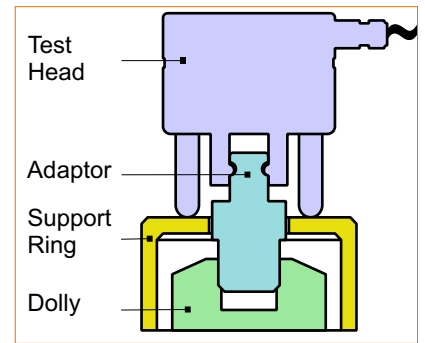

### 6.3kN (1416lbf) Test Head Accessories

Part Number		Description <sup>a</sup>	Range	Adaptor	Support Ring
Pack of 10	Pack of 100				
KT001910P004	KT001910P204	8.2mm (0.32") Dolly	0 - 120MPa (17400psi)	K0001910P401 <sup>*</sup>	KT001910P108 <sup>*</sup>
KT001910P005	KT001910P205	14.2mm (0.56") Dolly	0 - 40MPa (5800psi)	-	KT001910P109 <sup>*</sup>
KT001910P006	KT001910P206	20.0mm (0.79") Dolly	0 - 20MPa (2900psi)	-	KT001910P110 <sup>*</sup>
KT001910P010	KT001910P210	28.2mm (1.11") Dolly	0 - 10MPa (1450psi)	-	KT001910P111 <sup>*</sup>
KT001910P012	KT001910P212	50.0mm (2.00") Dolly	0 - 3.2MPa (460psi)	KT001910P406 <sup>*</sup>	KT001910P101 <sup>*1</sup> KT001910P102 <sup>*2</sup> KT001910P123 <sup>*2</sup>
KT001910P018	KT001910P218	70.0mm (2.76") Dolly	0 - 5MPa (725psi)	KT001910P406 <sup>*</sup>	KT001910P102 <sup>*2</sup> KT001910P123 <sup>*3</sup>
KT001910P016	KT001910P216	50x50mm (2 x 2") Dolly	0 - 7.85MPa (1140psi)	KT001910P406 <sup>*</sup>	KT001910P102 <sup>*2</sup> KT001910P123 <sup>*3</sup>

### 20kN (4496lbf) Test Head Accessories

Part Number		Description <sup>a</sup>	Range	Adaptor <sup>♦</sup>	Support Ring
Pack of 10	Pack of 100				
KT001910P007	KT001910P207	25.0mm (0.98") Dolly	0 - 40MPa (5800psi)	KT001910P407 <sup>*</sup>	-
KT001910P012	KT001910P212	50.0mm (2.00") Dolly	0 - 10MPa (1450psi)	KT001910P406 <sup>*</sup>	KT001910P101 <sup>*1</sup> KT001910P102 <sup>*2</sup> KT001910P123 <sup>*2</sup>
KT001910P018	KT001910P218	70.0mm (2.76") Dolly	0 - 5MPa (460psi)	KT001910P408 <sup>*</sup>	KT001910P102 <sup>*2</sup> KT001910P123 <sup>*3</sup>
KT001910P016	KT001910P216	50 x 50mm (2 x 2") Dolly	0 - 7.85MPa (1140psi)	KT001910P408 <sup>*</sup>	KT001910P102 <sup>*2</sup> KT001910P123 <sup>*3</sup>

\* Optional   ♦ Required   <sup>1</sup> Standard - 50mm (1.97")   <sup>2</sup> Large - 70mm (2.76")   <sup>3</sup> Adjustable - for 50 x 50mm and 70mm dollies

<sup>a</sup> All dimensions given are the dolly diameter

**40kN (8892lbf) Test Head Accessories**

Part Number		Description <sup>a</sup>	Range	Adaptor	Support Ring
Pack of 10	Pack of 100				
KT001910P007	KT001910P20	25.0mm (0.98")Dolly	0 - 80MPa (11600psi)	-	-
KT001910P012	KT001910P21	50.0mm (2.00") Dolly	0 - 20MPa (1450psi)	KT001910P409 <sup>*</sup>	KT001910P101 <sup>*1</sup> KT001910P102 <sup>*2</sup> KT001910P123 <sup>*3</sup>
KT001910P018	KT001910P21	70.0mm (2.76")Dolly	0 - 10MPa (460psi)	KT001910P409 <sup>*</sup>	KT001910P102 <sup>*2</sup> KT001910P123 <sup>*3</sup>
KT001910P016	KT001910P21	50 x 50mm (2 x 2") Dolly	0 - 15.6MPa	KT001910P409 <sup>*</sup>	KT001910P102 <sup>*2</sup> KT001910P123 <sup>*3</sup>

\* Optional    <sup>\*</sup> Required    <sup>1</sup> Standard - 50mm (1.97")    <sup>2</sup> Large - 70mm (2.76")    <sup>3</sup> Adjustable - for 50 x 50mm and 70mm dollies

<sup>a</sup> All dimensions given are the dolly diameter

Accessories

KT001910P501	Additional Testing Head 6.3kN (1416lbf)
KT001910P502	Additional Testing Head 20.0kN (4496lbf)
KT001910P503	Additional Testing Head 40.0kN (8992lbf)
KT001910P116	Cutting Tool for 8.2mm (0.32") Diameter Dollies
KT001910P117	Cutting Tool for 14.2mm (0.56") Diameter Dollies
KT001910P118	Cutting Tool for 20.0mm (0.79") Diameter Dollies
KT001910P119	Cutting Tool for 25.0mm (0.98") Diameter Dollies
KT001910P120	Cutting Tool for 28.2mm (1.11") Diameter Dollies
KT001910P122	Cutting Tool for 50.0mm (2.00") Diameter Dollies

## Elcometer 110 PATTI® Adhesion Tester

The Elcometer 110 PATTI® is a portable, pneumatic adhesion tester which uses compressed gas from either a cylinder or compressed air feed.

Due to the controlled force being applied, the resultant adhesion value is very repeatable. This provides the User with an ideal testing instrument that is simple to use and has a  $\pm 1\%$  accuracy<sup>†</sup>.

A wide range of interchangeable pistons is available, providing the user with a maximum adhesion test of 70MPa, 10,000psi with a link to an external air supply or CO<sub>2</sub> canister. Pistons are sold separately.



### Technical Specification

certificate available

Part Number	Description
<b>F110----A</b>	Elcometer 110 Pneumatic Adhesion Tester
Gas Supply	Internal reservoir rechargeable from external gas cylinder or external air line
Power Supply	9V (PP3, 6F22) or 110 - 240V AC powered with optional adaptor
Dimensions	100 x 255 x 225mm (4 x 10.5 x 10.5")
Pull Stub	12.7mm (0.5")
Diameter	2.7kg (5.9lbs) without carry case
Weight	Adjustable up to 150psi/second
Rate of increase	Adhesion Tester, pull stubs (x 25), cut-off rings (x 25), talcum powder, epoxy adhesive, carry case and operating instructions

Can be used in accordance with: (see Standards Explained inside Front Cover)  
**ASTM D 4541, AS/NZS 1580.408.5, ISO 16276-1**

<sup>†</sup>Accuracy depends on the positioning of the dolly,  $\pm 1\%$  when tested under factory conditions

Pistons, for use with the control module, to be ordered separately

Part Number	Piston	Load Range		Piston Diameter	
		MPa	psi	mm	inches
<b>T11013400</b>	F-1 Piston	0 - 3.4	0 - 500	44.5	1.75
<b>T11013401</b>	F-2 Piston	0 - 6.9	0 - 1000	57	2.25
<b>T11013402</b>	F-4 Piston	0 - 13.8	0 - 2000	76	3
<b>T11013403</b>	F-8 Piston	0 - 27.6	0 - 4000	98	3.875
<b>T11013404</b>	F-16 Piston	0 - 55.2	0 - 8000	127	5
<b>T11013405</b>	F-20	0 - 70	0 - 10000	146	5.75
<b>T11013388</b>	Pull Stub, 12.7mm (0.5") Diameter (pack of 25)				
<b>T11013389</b>	Cut-off Ring, 12.7mm (0.5") Diameter (pack of 25)				
<b>T11014019</b>	Pull Stub Cutter, 12.7mm (0.5") Diameter				
<b>T11013261</b>	Connecting Hose Extension, 2m (78")				
<b>T11013455</b>	Compressed Air Supply Hose Assembly				
<b>T99912906</b>	Araldite Epoxy Adhesive				
<b>T1109987-</b>	240V Power Adaptor				
<b>T1109988-</b>	220V Power Adaptor				
<b>T1109989-</b>	110V Power Adaptor				
<b>T11019559</b>	CO <sub>2</sub> Cartridge Holder				

**Piston Selector**

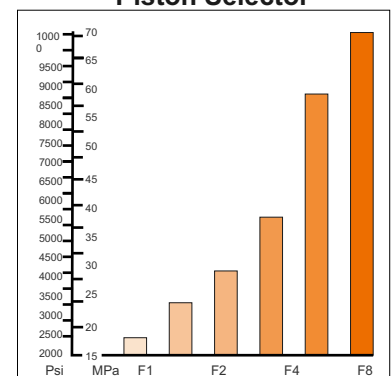

## Pinhole & Porosity Detection

Premature corrosion of a substrate is usually due to a coating failure. A major cause is the presence of flaws in the finished coating. Collectively referred to as *porosity*, the main types of flaws are:

**Runs & Sags:** Coatings move under gravity leaving a thin dry film.

**Cissing:** When a coating does not re-flow to cover the voids generated by air bubbles being released from the surface of a coating.

**Cratering:** If the substrate is wet or the coating has poor flow characteristics, voids are created in the coating.

**Pinholes:** Caused by air entrapment which is then released from the surface, or by the entrapment of particulates (dust, sand etc.) which do not stay in place.

**Over Coating:** If too much coating is applied, as it cures internal stresses of the coating can cause it to crack.

**Under Coating:** Un-coated areas, or where the coating flows away from edges or corners of a substrate or welds. Insufficient coating over a rough surface profile may also leave the peaks of the profile exposed.

There are, essentially, three flaw detection methods:

### Wet Sponge Technique

Suitable for measuring insulating coatings less than 500µm (20mils) on conductive substrates, the wet sponge technique is ideal for powder coatings and any thin coatings where the user does not wish to damage the coating.

A low voltage is applied to a moist sponge. When the sponge moves over a coating flaw, liquid penetrates to the substrate and completes an electrical circuit, setting off the alarm.

### UV Pinhole Detection

UV light can be used as a low cost, quick method of detecting pinholes in coatings. A base coat containing a UV fluorescing additive is applied. When the UV flashlight shines on the coating, areas where the base coat is not covered fluoresce, identifying the location of the pinhole.

### High Voltage Technique

The high voltage, or porosity technique, can be used to test coatings up to 7.5mm (300mils) thick and is ideal for inspecting pipelines and other protective coatings. Coatings on concrete can also be tested using this method.

A power supply generates a high voltage DC to a probe. As the probe passes over a flaw, a spark at the contact point sets off the alarm. This technique is suitable for locating the types of flaws described above, care is required on thin coatings.



## Elcometer 270 Pinhole Detectors

The Elcometer 270 range utilises the wet sponge technique and has been designed to set a new standard for wet sponge detectors - a high quality, low voltage detector with similar accessories to a high voltage spark tester.

- Supplied ready to use
- Automatic sensitivity calibration and voltage checks
- Low battery indicator
- Visual and audible alarms
- Integral and separate wand functionality
- A wide range of fully interchangeable wand accessories - see page 229
- Three model variants - single, dual or triple voltages
- Easy release snag proof cables
- Large standard sponge
- An inspection kit for all your requirements is available as an accessory



### Technical Specification

certificate available

Model	Elcometer 270/3	Elcometer 270/2	Elcometer 270/4
Part Number	D270----3	D270----2	D270----4
Voltage	9V and 90V	67.5V	9V, 67.5V and 90V
Maximum Measurement Range	500µm (20mils)	500µm (20mils)	500µm (20mils)
Sensitivity	9V: 90kΩ ±5% 90V: 400kΩ ±5%	125kΩ ±5%	9V: 90kΩ ±5% 67.5V: 125kΩ ±5% 90V: 400kΩ ±5%
Battery Life (continuous use)	9V: up to 200 hours 90V: up to 80 hours	Up to 100 hours	9V: up to 200 hours 67.5V: up to 100 hours 90V: up to 80 hours
Battery Type	3 x AA (LR1600) 1.5V alkaline (NiMH rechargeable batteries can also be used, battery life will be reduced by up to 75%)		
Accuracy of Setting	±5%		
Dimensions	Without wand	210 x 42 x 37mm (8.3 x 1.7 x 1.5")	
	Standard wand	175mm (6.9") long (including sponge)	
	Flat sponge	150 x 60 x 25mm (6 x 2.4 x 1") approx.	
Weight	610g (21oz) including wand, cable and batteries		
Packing List	Pinhole Detector, standard wand and sponge, 4m (13'2") return lead with crocodile clip, 3 x LR1600 (AA) batteries and operating instructions		

Can be used in accordance with: (see Standards Explained inside Front Cover)

ASTM 3894.2, ASTM G6, ASTM G62-A, ASTM D 5162 A, BS 7793-2, ISO 8289, ISO 8289 A, ISO 14654, NACE RP 0188, NACE TM0384



## Accessories



- T27016960 Roller Sponge Wand  
T27018051 Spare Roller Sponge Set



- T27016867 Standard Wand with Flat Sponge  
T27018050 Spare Rectangular Sponges (Pack of 3) - 150 x 60 x 25mm (6 x 2.3 x 1")



- T27018024 Wetting Agent 50ml (1.7 fl oz)



- T27016999 Separate Wand Adaptor with Belt Clip



- T27016998 Telescopic Handle with Belt Clip - Extends to 1m (39")



- T27016965 420mm (16.5") Extension Piece



- T99916996 10m (32'10") Signal Return Cable and Storage Drum



- T27018191 Inspector's Kit - each kit is supplied with:  
1 x separate wand handle & lead, 1 x roller wand, 1 x 10m (33') signal return cable, 2 x extension pieces, 1 x telescopic extension, 1 x belt clip, 1 x bottle of wetting agent, 3 x AA batteries, 1 x spare flat sponge, 1 x spare roller sponge  
*The Inspector's Kit does not include the main instrument; simply add the model number to the order.*

## Elcometer 260 Surefire® Fluorescinator UV Pinhole Flashlight

The Elcometer 260 provides a quick, low cost method of testing coatings for pinholes.

Developed for the industrial and marine markets, the Elcometer 260 features a six Watt purple Class 1 light emitting diode. The flashlight has a beam wavelength of 405nm ( $\pm 5\mu\text{m}$ ), which the human eye perceives as a purple light.

A UV reflecting additive is applied to the base coat. When the UV flashlight shines the purple light on the coating, any areas where the base coat is not covered by subsequent coating fluoresces, clearly identifying any pinholes.

Battery powered, the Elcometer 260 features a click-on/push-off button with a lockout tailcap to prevent accidental activation during transport or storage.

The flashlight is manufactured from rugged aerospace-grade aluminium and is O-ring sealed to protect it from moisture, dust or coating particulates. A Pyrex® lens with an anti-reflective coating adds to its durability.



### Technical Specification

Part Number	D260----1
Light Source	Class 1 Light Emitting Diode (LED) IEC60825-1 (A2:2002)
Beam Wavelength	405nm $\pm 5\text{nm}$
Flashlight Casing	Hard anodised aluminium
Battery Life	45 minutes (continuous use)
Battery Type	2 x 123A lithium batteries
Lens Type	Pyrex® lens with anti-reflective coating
Power Output	6 Watts
Dimensions	150 x 38mm (6 x 1.5")
Weight	190g (6.75oz)
Packing List	Elcometer 260 Surefire® Fluorescinator UV Pinhole Flashlight, 2 x 123A lithium batteries, operating instructions

*Can be used in accordance with: (see Standards Explained inside Front Cover)*

**ASTM E2501**

### Accessories

T26020140	UV Protective Glasses
T26020141	2 x Replacement Lithium 123A Batteries

## Elcometer 266 DC Holiday Detector

The Elcometer 266 revolutionises high voltage DC testing of coatings porosity detection making it safer, easier and more reliable than ever before.

Voltage adjustable using the keypad - no need for screwdriver:  
0.5kV - 1kV in 50V steps  
1kV to 30kV in 100V steps

Voltage calculator automatically sets the correct voltage from your coating thickness value

Internal Voltmeter/Jeep tester ensures that the selected voltage equals the test

5kV, 15kV and 30kV DC versions available

Audible and visual alarms are activated when a flaw is detected

Specialised ribbing provides superior protection while an optional second hand grip is ideal for two handed use

Dual safety switch on handle to avoid accidental switch on

Battery packs can be recharged inside or outside the gauge for continued use

Adaptor enables use of accessories from other manufacturers



## Elcometer 266 Features



No need to use look up tables with the integrated voltage calculator. Enter the test standard and the coating thickness and the gauge will automatically programme the correct voltage.

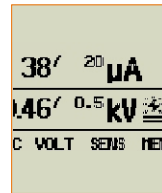

Adjust voltage via keypad on the gauge, with no need for screwdrivers. Sensitivity to current can be manually preset or automatically adjusted by the gauge for partially conductive coatings.



Interchangeable Probe Handles:  
500 - 5,000 Volts  
500 - 15,000 Volts  
500 - 30,000 Volts

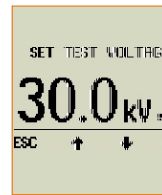

Internal calibrated jeep tester and closed loop system ensures that the generated test voltage is accurately measured and continuously controlled, regardless of climatic conditions.



Bright LEDs on the handle, as well as a loud audible alarm, clearly indicate if the gauge is on (Red) and when a spark is detected (Blue).



The optional second hand grip is designed for two handed use without compromising its safety. Ideal for testing pipes and tank floors.

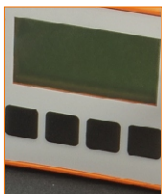

Large, backlit display enables easy viewing even in dark environments. When a flaw is detected the backlight also flashes.



The easy to use menu driven displays can be viewed in multiple languages for optimum versatility.



Rechargeable battery packs can be charged inside or outside the gauge. Batteries are fully charged within 4 hours and provide up to 40 hours continuous use between charges.



Elcometer 266 can be used with the accessories from the following gauges:  
Elcometer 236 & Elcometer 136  
Models AP, APS, AP/S1 & AP/S2  
Models 780, 785 & 790  
Models 10/20 & 14/20  
Compact DC & Compact Pulse

## Elcometer 266 Safety Features



2-stage safety switch ensures that if the Elcometer 266 handle is not gripped, the handle will switch off.



The extended ribbing provides protection to the user and has been specifically designed to meet standard EN61010. High voltage testing has never been safer.



The speaker on the gauge clearly emits a ticking noise to indicate that there is voltage at the handle.

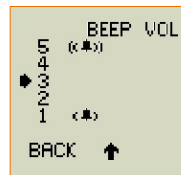

A loud audible alarm is activated when a spark is detected. The beep volume can also be adjusted to ensure it can be heard - even in noisy environments.

### Technical Specification

 certificate available

Part Number	D266----1	D266----2	D266----3
Voltage	UK 230V	EUR 230V	US 110V
Compatible with 0 - 5kV Handle*	■	■	■
Compatible with 0 - 15kV Handle*	■	■	■
Compatible with 0 - 30kV Handle*	■	■	■
Waterproof IP65 Case	■	■	■
High Voltage Output Accuracy	±5% or ±50V below 1000 Volts		
Measured Current Flow Accuracy	±5% of full scale		
Display Resolution	100 Volts, 1µA		
Output Current	0 - 100µA maximum		
Operating Temperature	0°C to 50°C (32°F to 120°F)		
Power Supply	Internal rechargeable lithium ion battery, fully charged within 4 hours		
Typical Battery Life (Backlight Off)	DC5: 40 hours	DC15: 20 hour	DC30: 10 hours
Typical Battery Life (Backlight On)	DC5: 20 hours	DC15: 15 hours	DC30: 8 hours
Instrument Case	High impact ABS		
Earth Lead Length	10m (33')		
Dimensions	520 x 370 x 125mm (20.5 x 14.5 x 5")		
Weight	Base unit (including battery pack): 1.2kg (2.7lb) Handle: 0.6kg (1.3lb)		
Packing List	Elcometer 266 DC Holiday Detector, lithium battery, curly connection cable for high voltage handle, 10m (33') earth signal return lead with crocodile clip, battery charger and mains cable, band brush, shoulder strap, tough plastic carry case and operating instructions		

Can be used in accordance with: (see Standards Explained inside Front Cover)

AS 3894.1, ASTM D 4787, ASTM G 6, ASTM D 5162-B, ASTM G 62-B, BS1344-11, EN 14430, ISO 2746, NACE RP0274, NACE RP0188, NACE RP0490, NACE SP0188

\*The Elcometer 266 DC Holiday Detector does not include the handle; select the required handle from the part numbers listed on the next page

## Accessories



		Voltage Output	Coating Range
T26620033-1	Elcometer 266 DC5 Handle	500 - 5,000V	1.25mm (50mils)
T26620033-2	Elcometer 266 DC15 Handle	500 - 15,000V	3.75mm (150mils)
T26620033-3	Elcometer 266 DC30 Handle	500 - 30,000V	7.50mm (300mils)
T26620081	Additional Hand Grip		
T26619975	Band Brush Probe		
T26619988-1	Probe Extension Piece (Short) 500mm (20")		
T26619988-2	Probe Extension Piece (Long) 1000mm (39")		
T99916996	Earth Signal Return Lead 10m (33')		



T26620082	Elcometer 236 and Elcometer 136 to Elcometer 266 Adaptor
T26620083	Models P20, P40, P60, 780, 785 and 790 to Elcometer 266 Adaptor
T26620084	Models AP, APS, AP/S1, AP/S2, AP/W 10/20 & 14/20, 10, 20, 20S to Elcometer 266



		Width	Electrode only
T26620022-11	Right Angle Rubber Probe	250mm (9.8")	T99926731
T26620022-12	Right Angle Rubber Probe	500mm (19.7")	T99926732
T26620022-13	Right Angle Rubber Probe	1000mm (39")	T99926733
T26620022-14	Right Angle Rubber Probe	1400mm (55")	T99926734



		Width	Electrode only
T26620022-1	Right Angle Wire Brush Probe	250mm (9.8")	T99926621
T26620022-2	Right Angle Wire Brush Probe	500mm (19.7")	T99926622
T26620022-3	Right Angle Wire Brush Probe	1000mm (39")	T99926623



	Full Assembly	Internal Pipe Diameter	Brush only
T26620071-1	Internal Pipe Wire Brush Assembly	38mm (1.5")	T9993766-
T26620071-2	Internal Pipe Wire Brush Assembly	51mm (2")	T9993767-
T26620071-3	Internal Pipe Wire Brush Assembly	64mm (2.5")	T9993768-
T26620071-4	Internal Pipe Wire Brush Assembly	76mm (3")	T9993769-
T26620071-5	Internal Pipe Wire Brush Assembly	89mm (3.5")	T9993770-
T26620071-6	Internal Pipe Wire Brush Assembly	102mm (4")	T9993771-
T26620071-7	Internal Pipe Wire Brush Assembly	114mm (4.5")	T9993772-
T26620071-8	Internal Pipe Wire Brush Assembly	127mm (5")	T9993773-
T26620071-9	Internal Pipe Wire Brush Assembly	152mm (6")	T9993774-
T26620071-10	Internal Pipe Wire Brush Assembly	203mm (8")	T9993775-
T26620071-11	Internal Pipe Wire Brush Assembly	254mm (10")	T9993776-
T26620071-12	Internal Pipe Wire Brush Assembly	305mm (12")	T9993777-

*Full assembly includes wire brush, holder and 250mm extension piece.*

T26619950	Rechargeable Battery Pack
T26619893	Curly Connecting Cable

T26620086 Elcometer 266 Spring Holder (rolling spring to be ordered from the list below)

Rolling Spring	Nominal Pipe Size		Pipe Outside Diameter (OD)			
	DN (mm)	NPS (inches)	(mm)		(inches)	
			min	max	min	max
T99920438-15A	40	1.5	48	54	1.9	2.1
T99920438-15B			54	60	2.1	2.4
T99920438-20A	50	2	60	66	2.4	2.6
T99920438-20B			66	73	2.6	2.9
T99920438-25A	65	2.5	73	80	2.9	3.1
T99920438-25B			80	88	3.1	3.5
T99920438-30A	80	3	88	95	3.5	3.7
T99920438-30B			95	100	3.7	3.9
T99920438-35A	90	3.5	100	108	3.9	4.3
T99920438-35B			108	114	4.3	4.5
T99920438-40A	100	4	114	125	4.5	4.9
T99920438-45A	114	4.5	125	136	4.9	5.4
T99920438-45B			136	141	5.4	5.6
T99920438-50A	125	5	141	155	5.6	6.1
T99920438-50B			155	168	6.1	6.6
T99920438-60A	152	6	168	180	6.6	7.1
T99920438-60B			180	193	7.1	7.6
T99920438-70A	178	7	193	213	7.6	8.4
T99920438-70B			213	219	8.4	8.6
T99920438-80A	203	8	219	240	8.6	9.4
T99920438-90A	229	9	240	264	9.4	10.4
T99920438-100A	254	10	264	290	10.4	11.4
T99920438-110A	279	11	290	320	11.4	12.6
T99920438-120A	305	12	320	350	12.6	13.8
T99920438-140A	356	14	350	375	13.8	14.8
T99920438-140B			375	400	14.8	15.7
T99920438-160A	406	16	400	435	15.7	17.1
T99920438-160B			435	450	17.1	17.7
T99920438-180A	457	18	450	500	17.7	19.7
T99920438-200A	508	20	500	550	19.7	21.7
T99920438-220A	559	22	550	600	21.7	23.6
T99920438-240A	610	24	600	650	23.6	25.6
T99920438-260A	660	26	650	700	25.6	27.6
T99920438-280A	711	28	700	750	27.6	29.5
T99920438-300A	762	30	750	810	29.5	31.9
T99920438-320A	813	32	810	860	31.9	33.9
T99920438-340A	864	34	860	910	33.9	35.8
T99920438-360A	914	36	910	960	35.8	37.8
T99920438-380A	965	38	960	1010	37.8	39.8
T99920438-400A	1016	40	1010	1060	39.8	41.7
T99920438-420A	1067	42	1060	1110	41.7	43.7
T99920438-440A	1118	44	1110	1160	43.7	45.7
T99920438-460A	1168	46	1160	1210	45.7	47.6
T99920438-480A	1219	48	1210	1270	47.6	50.0
T99920438-500A	1270	50	1270	1320	50.0	52.0
T99920438-520A	1321	52	1320	1370	52.0	53.9
T99920438-540A	1372	54	1370	1425	53.9	56.1

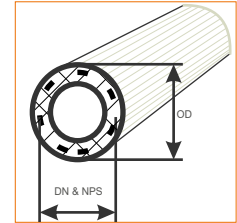

## Elcometer 236 DC Holiday Detector

This instrument performs high voltage testing to detect pits, holes, flaws etc. in coatings.

The Elcometer 236's convenient carry case allows the probe handle and accessories to be attached to the front making the Elcometer 236 ideal for field, site or laboratory inspection.

An accessory pouch, which accommodates the additional rechargeable battery (optional) can also be attached to the soft carry case - thereby extending inspection time without the need for recharging the unit.



- Robust and fully portable
- Audio and visual alarms for noisy environments
- Supplied with a band brush probe
- Digital display of output voltage or current
- Adjustable sensitivity
- 15kV and 30kV options available with fully adjustable output voltage

The Elcometer 236 is available in two versions: 0.5 - 15kV and 0.5 - 30kV. Each unit provides the user with complete control of voltage and sensitivity settings.

### Technical Specification

certificate available

Part Number	D236--15A UK 230V	D236--30A UK 230V
	D236--15B EUR 230V	D236--30B EUR 230V
	D236--15D US 110V	D236--30D US 110V
Voltage Output	0.5 - 15kV in 100V steps	0.5 - 30kV in 100V steps
Display Resolution	0.01kV	0.1kV
Range of Coating Thickness	0 - 3.75mm (approximate)	0 - 7.5mm (approximate)
	0 - 150mils (approximate)	0 - 300mils (approximate)
Alarms	Audible & Visual	
Power Supply	NiMH 12V internal rechargeable battery	
Battery Life (approximate)	10/12 hours continuous use, the optional external battery pack can increase this to 20/24 hours of continuous use	
Dimensions	200 x 170 x 70mm (6 x 7 x 3")	
Weight	2.8kg (6lb 3oz)	
Packing List	Elcometer 236, probe handle and lead, band brush probe, 2m (79") & 10m (394") signal return/earth leads, battery charger, carry case, transit case and operating instructions	

Can be used in accordance with: (see Standards Explained inside Front Cover)

AS 3894.1, ASTM D 4787, ASTM G 6, ASTM D 5162-B, ASTM G 62-B, BS1344-11, EN 14430, ISO 2746, JIS G 3491, NACE RP0188, NACE RP0274, NACE RP0490, NACE SP0188



## Accessories



T236155971	Telescopic Probe Handle, 600 - 1200mm (24 - 47")
T236155972	Telescopic Probe Handle, 1800 - 3600mm (71 - 142")



T2362669-	Band Brush Probe
-----------	------------------

T2362663A	Probe Extension Piece	250mm (9.8")
T2362663B	Probe Extension Piece	500mm (19.7")
T2362663C	Probe Extension Piece	1000mm (39.4")
T2362666-	Coupling Piece	



		Width	Electrode only
T23638081	Right Angle Rubber Probe	250mm (9.8")	T99926731
T23638082	Right Angle Rubber Probe	500mm (19.7")	T99926732
T23638083	Right Angle Rubber Probe	1000mm (39.4")	T99926733



T23638071	Right Angle Wire Brush Probe	250mm (9.8")	T99915511
T23638072	Right Angle Wire Brush Probe	500mm (19.7")	T99926622
T23638073	Right Angle Wire Brush Probe	1000mm (39.4")	T99926623



	Full Assembly*	Internal Pipe Diameter	Brush only
T2363907A	Internal Pipe Wire Brush Assembly	38mm (1.5")	T9993766-
T2363907B	Internal Pipe Wire Brush Assembly	51mm (2")	T9993767-
T2363907C	Internal Pipe Wire Brush Assembly	64mm (2.5")	T9993768-
T2363907D	Internal Pipe Wire Brush Assembly	76mm (3")	T9993769-
T2363907E	Internal Pipe Wire Brush Assembly	89mm (3.5")	T9993770-
T2363907F	Internal Pipe Wire Brush Assembly	102mm (4")	T9993771-
T2363907G	Internal Pipe Wire Brush Assembly	114mm (4.5")	T9993772-
T2363907H	Internal Pipe Wire Brush Assembly	127mm (5")	T9993773-
T2363907I	Internal Pipe Wire Brush Assembly	152mm (6")	T9993774-
T2363907J	Internal Pipe Wire Brush Assembly	203mm (8")	T9993775-
T2363907K	Internal Pipe Wire Brush Assembly	254mm (10")	T9993776-
T2363907L	Internal Pipe Wire Brush Assembly	305mm (12")	T9993777-

\* Full assembly includes wire brush, holder and 250mm extension piece.

T23615550	External Battery Pack
-----------	-----------------------

# Pinhole & Porosity

T23620507 Elcometer 236 Spring Holder (rolling spring to be ordered from the list below)

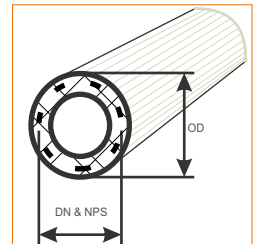

Rolling Spring	Nominal Pipe Size		Pipe Outside Diameter (OD)			
	DN (mm)	NPS (inches)	(mm)		(inches)	
			min	max	min	max
T99920438-15A	40	1.5	48	54	1.9	2.1
T99920438-15B			54	60	2.1	2.4
T99920438-20A	50	2	60	66	2.4	2.6
T99920438-20B			66	73	2.6	2.9
T99920438-25A	65	2.5	73	80	2.9	3.1
T99920438-25B			80	88	3.1	3.5
T99920438-30A	80	3	88	95	3.5	3.7
T99920438-30B			95	100	3.7	3.9
T99920438-35A	90	3.5	100	108	3.9	4.3
T99920438-35B			108	114	4.3	4.5
T99920438-40A	100	4	114	125	4.5	4.9
T99920438-45A	114	4.5	125	136	4.9	5.4
T99920438-45B			136	141	5.4	5.6
T99920438-50A	125	5	141	155	5.6	6.1
T99920438-50B			155	168	6.1	6.6
T99920438-60A	152	6	168	180	6.6	7.1
T99920438-60B			180	193	7.1	7.6
T99920438-70A	178	7	193	213	7.6	8.4
T99920438-70B			213	219	8.4	8.6
T99920438-80A	203	8	219	240	8.6	9.4
T99920438-90A	229	9	240	264	9.4	10.4
T99920438-100A	254	10	264	290	10.4	11.4
T99920438-110A	279	11	290	320	11.4	12.6
T99920438-120A	305	12	320	350	12.6	13.8
T99920438-140A	356	14	350	375	13.8	14.8
T99920438-140B			375	400	14.8	15.7
T99920438-160A	406	16	400	435	15.7	17.1
T99920438-160B			435	450	17.1	17.7
T99920438-180A	457	18	450	500	17.7	19.7
T99920438-200A	508	20	500	550	19.7	21.7
T99920438-220A	559	22	550	600	21.7	23.6
T99920438-240A	610	24	600	650	23.6	25.6
T99920438-260A	660	26	650	700	25.6	27.6
T99920438-280A	711	28	700	750	27.6	29.5
T99920438-300A	762	30	750	810	29.5	31.9
T99920438-320A	813	32	810	860	31.9	33.9
T99920438-340A	864	34	860	910	33.9	35.8
T99920438-360A	914	36	910	960	35.8	37.8
T99920438-380A	965	38	960	1010	37.8	39.8
T99920438-400A	1016	40	1010	1060	39.8	41.7
T99920438-420A	1067	42	1060	1110	41.7	43.7
T99920438-440A	1118	44	1110	1160	43.7	45.7
T99920438-460A	1168	46	1160	1210	45.7	47.6
T99920438-480A	1219	48	1210	1270	47.6	50.0
T99920438-500A	1270	50	1270	1320	50.0	52.0
T99920438-520A	1321	52	1320	1370	52.0	53.9
T99920438-540A	1372	54	1370	1425	53.9	56.1

## Inspection Accessories

Elcometer offers a range of inspection and visual comparison manuals specifically for the coatings inspector.

Elcometer also provides a range of Pictorial Surface Standards for blast cleaning incorporating standards for BS, ISO, SIS, and SSPC.

The publications are related to different aspects of the testing we offer. In general they offer reference information on paint testing methods and related inspection requirements.

The Macaw's Pipeline Defects is a text book specific to pipelines and contains information on pipeline coatings.

During inspection, sometimes the substrate or coating requires closer investigation. In dark or shaded areas such as in ballast tanks or on large production sites, further investigation may require additional light.

It may be necessary to take a detailed look at a specific area where you cannot get to. In this case an inspection mirror is required. For close up investigations, the inspector may require magnification of the surface for a clearer understanding.



## Elcometer 128 Pictorial Surface Standards

Elcometer’s range of Surface Standards cover most standards required for surface cleanliness. Surface Standards:

- ISO 8501, SIS 055900 - The Swedish Standard
- VIS 1-01 - The SSPC Standard
- VIS 2 - The SSPC Standard
- VIS-3 - The SSPC Standard
- VIS 4 - The SSPC Standard
- VIS 5 - The SSPC Standard
- BS EN ISO 8501-4:2006



### Technical Specification

Part Number	Description
E128----1	Swedish standard (ISO 8501-1, SIS 055900) - the original visual standard. It shows the degree of cleanliness of different levels of rusted steel cleaned by blasting, hand and power tools and flame. Specified by ASTM D2200 Method A
E128----3	SSPC (steel structures painting council) VIS 1-01 - similar to the Swedish and British standards, but the pictures of the required final appearances match the written descriptions in the USA standards. VISI 1-89 includes photographs of surfaces cleaned using metallic and non-matallic abrasives. Specified by ASTM D2200 Method B
E128----5	SSPC VIS-3 - contains 44 photographs to supplement the written SSPC specifications for hand and power-tool cleaning
E128----6	SSPC VIS2 Standard method of evaluating the degree of rusting on painted steel surfaces
E128----7	SSPC VIS4 Guide and reference photographs for steel surfaces prepared by water jetting
E128----8	SSPC VIS5 Guide and reference photographs for steel surfaces prepared by wet abrasive
E128----9	BS EN ISO 8501-4:2006 - preparation of steel substrates before application of paints and related products. Visual assessment of surface cleanliness. Initial surface conditions, preparation grades and flash rust grades in connection with high-pressure water jetting

*Can be used in accordance with: (see Standards Explained inside Front Cover)*

ASTM D 2200, BS EN ISO 8501-4 2006, IMO MSC.215(82), ISO 8501-1, SIS 055900, SSPC VIS 1, SSPC VIS 2, SSPC VIS 3, SSPC VIS 4, SSPC VIS 5, US Navy NSI 009-32

Customers who purchased the Elcometer 128 have also purchased:



◀ Elcometer 138 Bresle Salt Kit, page 255

Elcometer 224 Surface Profile Gauge, page 137 - 139



## Elcometer 144 Paint Safe Marker Pens

Paint Safe Marker Pens are used to highlight visual areas of non conformance, providing a clear indication of areas where rework or other processes need to be carried out.

The Safinah Marker pen has been specially selected for use as an inspection marker for all types of large steel fabrications including both coated or uncoated ships and offshore structures.

The pen is ideal for testing applications in the most sensitive areas and is available in Black.



### Technical Specification

Part Number	Description
H144----1	Elcometer Paint Safe Marker Pens (pack of 5)

## Elcometer 132 Safety Torch / Flash Light

Many environments can have low light or dark areas and explosive gas present; ballast tanks, oil and gas tanks, etc. It is imperative, not only for safety reasons, but also to be able to inspect the coating adequately, to have sufficient light.

The Elcometer 132 Safety Torch/Flash Light is explosion proof and meets the ATEX directive as category 2 equipment.

It is approved to the latest EN Standards for electrical apparatus for potential explosive atmospheres. This allows for use in Group II applications zones 1 and 2, IIA and IIB gases, where T4 temperature class permits.



### Technical specification

Part Number	Description
H132---1A	Elcometer 132 Safety Torch/Flash Light
Battery Type	3 x LR20 (D)
Dimensions	250 x 65 mm (9.8 x 2.5")
Weight	656g (1.44lb)
Packing List	Elcometer 132 Safety Torch/Flash Light and operating instructions

## Elcometer 131 Inspection Mirrors

Ideal for inspecting difficult to access areas - inside pipes, behind corners, underneath inspection tanks, and other inaccessible or awkward areas.

Combined with the full range of test equipment from Elcometer, these high quality, robust mirrors help to provide a detailed examination of the component or project under inspection.



### Technical Specification

Part Number	Description
<b>H131---1A</b>	Elcometer 131/1A Telescopic Inspection Mirror
<b>H131---1B</b>	Elcometer 131/1B Illuminated Inspection Mirror
<b>H131---1C</b>	Elcometer 131/1C Telescopic Inspection Mirror
<b>H131---2A</b>	Elcometer 131/2A Telescopic Inspection Mirror (Battery Type 2 x LR14 C)
Dimensions	Elcometer 131/1A - Extends from 350mm (14") to 1400mm (55") Mirror diameter: 63mm (2.5") Elcometer 131/1B - Extends from 165mm (6.5") to 925mm (36") Mirror diameter: 63mm (2.5") Elcometer 131/1C - Extends from 165mm (6.5") to 750mm (29.5") Mirror diameter: 82mm (3.25") Elcometer 131/2A - Mirror diameter: 63mm (2.5")
Weight	541g (1.23lb)
Packing List	Elcometer 131 Inspection Mirror and operating instructions



**H131---1A**  
Telescopic Inspection Mirror



**H131---1C**  
Telescopic Inspection Mirror



**H131---1B**  
Illuminated Inspection Mirror



**H131---2A**  
Telescopic Inspection Mirror

## Elcometer Fitz's Atlas of Coatings Defects

The Elcometer Fitz's Atlas of Coating Defects (EFA) takes the reader through a comprehensive range of problems and discusses each in detail.

EFA provides the User with a greater understanding of the defect, the probable cause and possible solutions. With in excess of 180 colour photographs, the user can quickly gain an insight into the coatings industry and the possible pitfalls.

Sections:

- Welding Faults
- Surface Conditions
- Dry Abrasive Blasting
- Water Jetting
- Coating Defects
- Marine Fouling Classifications

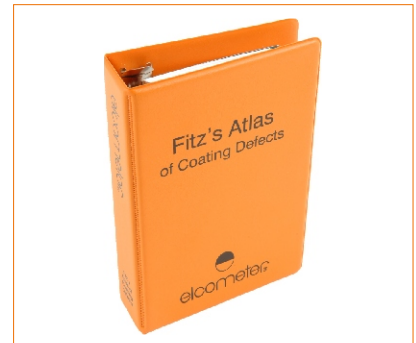

### Technical Specification

Part Number	
<b>H99916043</b>	Elcometer Fitz's Atlas of Coating Defects
Dimensions	223 x 220 x 70mm (9 x 8.6 x 3")
Weight	0.45kg (1lb)

## Elcometer Macaw's Pipeline Defects

The aim of this publication is to illustrate the range of defects that may be encountered in high pressure steel pipelines and pipeline coatings.

The manual gives advice on the probable cause and significance of the defects and comments on appropriate remedial actions.

The defects included in this book encompass all aspects of high pressure steel pipeline manufacture, construction and operation, together with sections on coating and cathodic protection defects and examples of how defects interact to generate new or modified risks to pipeline integrity.

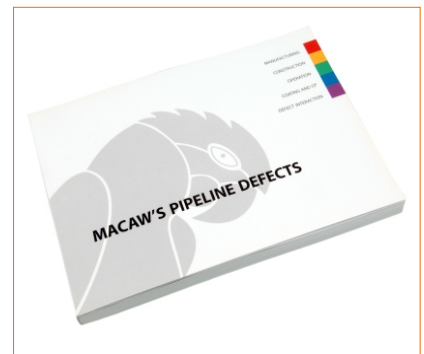

### Technical Specification

Part Number	
<b>H99918572</b>	Elcometer Macaw's Pipeline Defects
Dimensions	210 x 148 x 15mm (8 x 6 x 0.5")
Weight	0.4kg (1.1lb)

## Elcometer 137 Illuminated (x10) Magnifier

From time to time a closer inspection of a surface is required to ascertain the exact conditions of the material's profile, cleanliness etc.

Furthermore, many environments can be in low light or dark areas - ballast tanks, oil and gas tanks, etc. The Elcometer 137 illuminated magnifier is the ideal product for the job.

- Lightweight, battery powered, portable magnifier
- Ideal for viewing surface comparators
- x10 magnification for close surface inspection
- Scaled lens for easy measurement of surface features



### Technical Specification

Part Number	Description
<b>H137----1</b>	Elcometer 137 Illuminated Magnifier
Battery Type	3 x LR14 (C)
Dimensions	33 x 215mm (1.3 x 8.5")
Weight	236g (0.52lb)
Packing List	Elcometer 137 Illuminated Magnifier and operating instructions

## Elcometer 7210 Pocket (x30) Microscope

The Elcometer 7210 is pocket size making it an extremely practical microscope for site inspections.

Having x30 magnification and a inbuilt light source, the Elcometer 7210 Pocket Microscope is the ideal choice for close up investigation of defects and surface cleanliness.



### Technical Specification

Part Number	Description
<b>KT007210M001</b>	Elcometer 7210 Pocket Microscope
Battery Type	1 x LR03 (AAA)
Dimensions	140 x 50 x 22mm (5.5 x 2 x 0.9")
Weight	68g (0.14lb)
Packing List	Elcometer 7210 Pocket Microscope and operating instructions



## Elcometer 900 Illuminated (x50) Microscope

This is a very simple, graduated x50 microscope with internal illumination.

This allows the user to quickly determine width by counting the number of graduated reticules on the scaled lens and calculating the value.



### Technical Specification

Part Number	Description		
<b>W90018568-M</b>	Elcometer 900 Microscope - Metric		
<b>W90018568-E</b>	Elcometer 900 Microscope - Imperial		
Battery Type	1 x LR03 (AAA)		
Dimensions	120 x 43 x 115 mm (4.7 x 1.7 x 4.5")	Weight	145g (0.31lb)
Packing List	Elcometer 900 Illuminated Microscope and operating instructions		

## Elcometer 7220 Microscope with Reticules

A small robust and handy microscope with battery operated removable lighting unit. A wide range of magnifications is available with scales graduated in mm. Ideal for surface inspection and crack width determination.

- x20; 0.1mm graduations
- x60; 0.02mm graduations
- x200; 0.002mm graduations
- x40; 0.05mm graduations
- x100; 0.02mm graduations
- x300; 0.001mm graduations



### Technical Specification

Part Number	Description	Magnification
<b>K0007220M001</b>	Elcometer 7220/1 Microscope with Graduated Reticule	x20
<b>K0007220M002</b>	Elcometer 7220/2 Microscope with Graduated Reticule	x40
<b>K0007220M003</b>	Elcometer 7220/3 Microscope with Graduated Reticule	x60
<b>K0007220M004</b>	Elcometer 7220/4 Microscope with Graduated Reticule	x100
<b>K0007220M005</b>	Elcometer 7220/5 Microscope with Graduated Reticule	x200
<b>K0007220M006</b>	Elcometer 7220/6 Microscope with Graduated Reticule	x300
Battery Type	2 x LR06 (AA)	
Dimensions	63 x 172 mm (2.5 x 6.8")	Weight 241g (0.53lb)
Packing List	Elcometer 7220 Microscope with Graduated Reticule and operating instructions	

## Elcometer Galvanising Calculator

This simple calculator has been designed to help coating inspectors in the galvanising industry to convert the thickness of the zinc coating into the weight per unit area.

Values displayed in both metric and imperial.

- Metric:        microns into grams per square metre
- Imperial:     mils into ounces per square foot

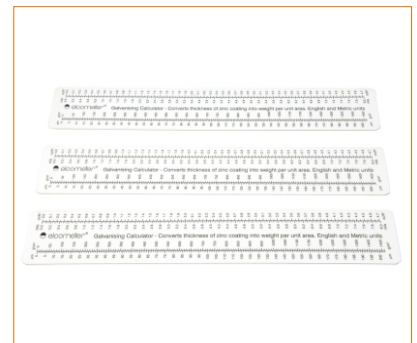

### Technical Specification

Part Number	Description	Metric	Imperial
<b>T95018569</b>	Elcometer Galvanising Calculator	203µm: 1450g/m <sup>2</sup>	8.0 mils: 4.7oz/ft <sup>2</sup>
Dimensions	22 x 3.5 cm (8.6 x 1.37")		
Weight	7g (0.24oz)		
Packing List	Galvanising Calculator		

Customers who purchased the Elcometer Galvanising Calculator also purchased:



◀ Elcometer 456 Digital Coating Thickness Gauge, page 148

Elcometer 355 Digital Coating Thickness Gauge, ▶ page 137



## Inspection Kits

Elcometer offers one of the widest ranges of inspection equipment available. Our products are used across numerous industry sectors. In all cases, there is always a need to undertake a number of specific inspections during quality control assessments - as one parameter can affect another.

For example, the thickness of an applied coating can affect properties such as adhesion, gloss, colour and porosity.

Elcometer has put together a series of industry and product specific inspection kits - combining a number of gauges from our range. Each kit is supplied in a convenient sturdy plastic carry case, ideal for transporting to and from the inspection site.

Industry specific kits include:

- **Marine Inspection Kits:**  
supplying all the products required to comply to IMO Performance Standard for Protective Coatings in Salt Water Ballast Tanks
- **Protective Coating Inspection Kits:**  
a number of kits to meet the varying needs of a protective coating inspector. Kits include both traditional and state of the art digital inspection methods
- **Powder Inspection Kits:**  
each kit contains a number of gauges for post application inspection of powder coated surfaces. Elcometer can also provide all the inspection products you require to meet the Qualicoat Standard.
- **Automotive Inspection Kits:**  
ideal for the automotive refinishing market
- **HVCA Duct Inspection Kits:**  
specially designed kits for inspection of dust, grease and grime in Heating, Ventilation and Air Conditioning Ducts

Product specific inspection kits include:

- **Bresle Salt Inspection Kit:**  
for measuring the level of soluble salts on a surface
- **CSN Inspection Kit:**  
for measuring the level of Chloride, Sulphate and Nitrate Ions on a surface
- **Surface Contamination Kit:**  
for testing the presence of pH, Chloride, Iron and soluble salts on a test surface
- **Custom Designed Kits:**

If the inspection kit that you require is not listed in this section, Elcometer will be happy to discuss your specific needs and create a customised kit for your application.



## Elcometer Marine Inspection Kit

The Elcometer Marine Inspection Kits have been designed to meet all the inspection requirements as specified in the IMO PSPC for Salt Water Ballast Tanks - Resolutions MSC.215(82) and MSC.215(84) - and includes the new Elcometer 456 with integrated 90/10 rule as required in the IMO regulation.

This Kit may be used in conjunction with ElcoShip™ software - for more details visit [www.elcoship.com](http://www.elcoship.com)

These inspection kits can also be used as a general inspection kit, ideal for pipelines, ships, bridges tanks, etc.



### Kit Contents

Model	Description	Product Information
Elcometer 456	Top Coating Thickness Gauge, Ferrous Separate Probe 0 - 5mm (200mils)	Page 188 - 198
Elcometer 128	Swedish Pictorial Standard - ISO 8501, SIS 055900	Page 154
Elcometer 319/2	Dewpoint Meter with Docking Unit*	Page 156 - 159
Elcometer 224	Digital Surface Profile Gauge <sup>#</sup>	Page 137 - 139
Elcometer 138	Bresle Conductivity Kit	Page 149
Elcometer 142	ISO 8502-3 Dust Tape Test Kit	Page 146
Elcometer 3236	Hexagonal Wet Film Comb	Page 179
Elcometer 144	Paint Safe Marker Pens (Pack of 5)	Page 241
Elcometer 124	Foil Gauge	Page 136
Elcometer 122	Testex Tape, Coarse, X-Coarse and Coarse Plus (1 Roll of Each)	Page 136

Can be used in accordance with: (see Standards Explained inside Front Cover)

AS 2331.1.4, AS 3894.3-B, AS/NZS 1580.107.3, AS/NZS 1580.108.1, ASTM B 499, ASTM D 1186-B, ASTM D 1400, ASTM D 4414-A, ASTM D 7091, ASTM E 376, ASTM G 12, BS 3900-C5, BS 3900-C5-6Aa, BS 3900-C5-7B, BS 5411-11, BS 5411-3, BS 5599, BS 7079-B4, DIN 50981, DIN 50984, EN 13523-1, IMO MSC.215(82), IMO MSC.216 (82), ISO 1461, ISO 19840, ISO 2063, ISO 2360, ISO 2808-1A, ISO 2808-7C, ISO 2808-7D, ISO 8502-6, NFT 30-125 - 3236 NFT30-124, NSTM 009-32, SS 184160, SSPC Guide 15-138/2, SSPC PA 2, US Navy PPI 63101-000, ISO 8502-4

### Technical Specification

Part Number	Description
<b>YKITMARINE-1S</b>	Elcometer Standard Marine Inspection Kit
<b>YKITMARINE-1T</b>	Elcometer Top Marine Inspection Kit
Dimensions	460 x 340 x 125mm (18.1 x 13.4 x 4.9")
Weight	Kit 1: 6kg (13lb) Kit 2: Top Kit 6.5kg (14.5lb)

\* Docking Unit supplied with Top Kit only    <sup>#</sup> Elcometer 224S supplied in Standard Kit, Elcometer 224T supplied in Top Kit

## Elcometer Protective Coating Inspection Kits 1 & 2

The Elcometer range of Protective Coatings Inspection Kits provides all the tools required for the on-site inspection of a coating, including surface profile, dewpoint, relative humidity and both wet and dry film thickness.

All of the three kits are available with or without an Elcometer 456 digital coating thickness gauge and are invaluable to the operator in the field to ensure the coating is, or has been, applied correctly and is fit for purpose, removing the need for guesswork.

The Elcometer 107 Cross Hatch Cutter, supplied with Kit 2, provides an instant assessment of the quality of the bond to the substrate. Due to its rugged construction, this gauge is ideal for thin, thick or tough coatings on flat or curved surfaces.



### Kit 1 and 2 Contents

Model	Description	Product Information
Elcometer 124	Foil Gauge	Page 136
Elcometer 122	Testex Tape, Coarse	Page 136
Elcometer 122	Testex Tape, Extra Coarse	Page 136
Elcometer 116	Sling Hygrometer °C (°F)	Page 160
Elcometer 212	Digital Thermometer °C (°F) with surface probe	Page 162
Elcometer 112	Hexagonal Wet Film Comb 25 - 3000µm (0 - 120mils)	Page 179
Elcometer 456(optional)	Ferrous Integral Coating Thickness Gauge <sup>#</sup> , Scale 1	Page 188 - 192
Elcometer 107*	Cross Hatch Cutter 6 x 2mm or 6 x 1mm	Page 217
Elcometer 107*	Elcometer 107 ISO or ASTM Adhesive Tape, 1 roll	Page 217

<sup>#</sup> The optional Elcometer 456 Ferrous Basic Integral supplied with Kit 1 and optional Elcometer 456 Ferrous Standard Integral, including ElcoMaster™ software, supplied with Kit 2

\* Supplied with Kit 2 only - ISO Tape with the Metric Unit, ASTM Tape with the Imperial Unit

### Technical Specification

Part Number	Description	
	Metric	Imperial
<b>YKITPROTECTIVE-1M</b>	<b>YKITPROTECTIVE-1E</b>	Elcometer Protective Coatings Kit 1 (with Elcometer 456 Basic)
<b>YKITPROTECTIVE-1MZ</b>	<b>YKITPROTECTIVE-1EZ</b>	Elcometer Protective Coatings Kit 1 (without Elcometer 456)
<b>YKITPROTECTIVE-2M</b>	<b>YKITPROTECTIVE-2E</b>	Elcometer Protective Coatings Kit 2 (with Elcometer 456 Standard)
<b>YKITPROTECTIVE-2MZ</b>	<b>YKITPROTECTIVE-2EZ</b>	Elcometer Protective Coatings Kit 2 (without Elcometer 456)
Dimensions	460 x 340 x 125mm (18.1 x 13.4 x 4.9")	
Weight	5kg (11lb)	

If the kit that you require is not listed above, Elcometer will be happy to discuss your requirements and create one to suit your particular needs. Alternative Elcometer 456 Coating Thickness gauges or scale ranges can be substituted in any kit upon request.

Can be used in accordance with: (see Standards Explained inside Front Cover)

AS 3894.9, AS 1580.408.4, ASTM D 3359-B, BS 3900-E6, ECCA T6, EN 13523-6, ISO 2409, ISO 16276-2, NF T30-038

## Elcometer Protective Coating Inspection Kit 3

### Inspection Kit 3

The Elcometer Protective Coatings Inspection Kit 3 moves inspection into the digital era, ready for paperless quality assurance. The Elcometer 319/2 Digital Dewmeter complements the more traditional inspection methods combining to make a well rounded, versatile inspection kit.

The Top Kit provides the benefit of the Top model of the Elcometer 224 and the Elcometer 319/2 complete with Docking Unit.



### Kit 3 Contents

Model	Description	Product Information
Elcometer 124	Foil Gauge	Page 136
Elcometer 122	Testex Tape, coarse	Page 136
Elcometer 122	Testex Tape, extra coarse	Page 136
Elcometer 224	Digital Surface Profile Gauge*	Page 137 - 139
Elcometer 319/2	Digital Dewmeter (with Docking Unit) <sup>#</sup>	Page 159
Elcometer 112	Hexagonal Wet Film Comb 25 - 3000µm (0 - 120mils)	Page 179
Elcometer 107	Cross Hatch Cutter 6 x 2mm or 6 x 1mm	Page 217
Elcometer 107	Elcometer 107 ISO or ASTM Adhesive Tape, 1 roll	Page 217
Elcometer 456 (optional)	Ferrous Standard Separate Digital Coating Thickness Gauge with Scale 1 Probe, 0 - 1500µm and ElcoMaster™ software	Page 188 - 198

\* Elcometer 224S supplied with Standard Kit, Elcometer 224T supplied with Top Kit

<sup>#</sup> Docking Unit supplied with Top Kit Only

### Technical Specification

Part Number	Description	
Metric	Imperial	
<a href="#">YKITPROTECTIVE-3SM</a>	<a href="#">YKITPROTECTIVE-3SE</a>	Elcometer Kit 3 Standard (with Elcometer 456)
<a href="#">YKITPROTECTIVE-3SMZ</a>	<a href="#">YKITPROTECTIVE-3SEZ</a>	Elcometer Kit 3 Standard (without Elcometer 456)
<a href="#">YKITPROTECTIVE-3TM</a>	<a href="#">YKITPROTECTIVE-3TE</a>	Elcometer Kit 3 Top (with Elcometer 456)
<a href="#">YKITPROTECTIVE-3TMZ</a>	<a href="#">YKITPROTECTIVE-3TEZ</a>	Elcometer Kit 3 Top (without Elcometer 456)
Dimensions	460 x 340 x 125mm (18.1 x 13.4 x 4.9")	
Weight	5.5kg (12.12lb)	

If the kit that you require is not listed above, Elcometer will be happy to discuss your requirements and create one to suit your particular needs. Alternative Elcometer 456 Coating Thickness gauges or scale ranges can be substituted in any kit upon request.

Can be used in accordance with:(see Standards Explained inside Front Cover)

AS 1580.408.4, AS 3894.9, AS/NZS 1580.107.3, ASTM D 4414-A, ASTM D 3359-B, ASTM D 4417-B, BS 3900-C5-7B, BS 3900-E6, BS 7079-B4, ECCA T6, EN 13523-6, IMO MSC.215(82), ISO 2409, ISO 2808-1A, ISO 8502-4, ISO 16276-2, NFT 30-125, NF T30-038, NSTM 009-32, SANS 5772, US Navy NSI 009-32, US Navy PPI 63101-000, NSTM 009-32, US Navy PPI 63101-000

## Elcometer Powder Coatings Inspection Kit

To cover all eventualities in the powder inspection process, Elcometer has produced a kit to enable the inspection of powder coatings on all surfaces.

For a smooth surface, the digital Elcometer 415 may be used, but, for more demanding, uneven, surfaces, the Elcometer 1542 is included.



### Kit Contents

Model	Description	Product Information
Elcometer 1542	Cross Hatch Cutter. 6 x 2mm or 6 x 1mm with ISO or ASTM Adhesive Tape	Page 218
Elcometer 415	Powder Coating Thickness Gauge	Page 187
Elcometer 137	Illuminated Magnifier (x10)	Page 244

### Technical Specification

Part Number	Description
ISO KIT	ASTM KIT
<b>YKITPOWDER-1M</b>	<b>YKITPOWDER-1E</b>
	Elcometer Powder Coatings Inspection Kit
Dimensions	360 x 300 x 120mm (12.2 x 10.2 x 3.1")
Weight	580g (1.27lb)

*Can be used in accordance with:(see Standards Explained inside Front Cover)*

ASTM B 244, **ASTM B 499**, ASTM D 1400, ASTM D 1186-B, **ASTM D 7091**, BS 5411-(3) (11), BS 3900 C5, DIN 50984, DIN 50981, **ISO 2178**, **ISO 2360**, **ISO 2808**

## Elcometer Qualicoat Powder Coating Inspection Kit

The Qualicoat Organisation brings together the ideals of several national coating associations into one quality label for the powder coating applied to aluminium architectural applications. The aim of Qualicoat is to establish the minimum standard that plant installations, coating materials and finished products which have been powder coated must meet.

Within this quality label, Qualicoat identifies a range of inspection requirements to be undertaken with regards to the quality control of powder coated products.

The Elcometer Qualicoat Powder Coating Inspection Kit provides the various test instrumentation required to meet the high standards of this organisation.



### Qualicoat Kit 1

Model	Description	Product Information
Elcometer 406L	Statistical Glossmeter: 60°	Page 108
Elcometer 3095	Buchholz Hardness Tester	Page 93
Elcometer 1506	Mandrel Bend Tester with 5mm and 8mm (0.20 and 0.31") Mandrels	Page 99
Elcometer 1615	Base Unit and Tube Assembly	Page 102 - 103
Elcometer 1615	Kit B: ISO 6272/2 and BS 6496	Page 104
Elcometer 415	FNF Integral Digital Coating Thickness Gauge for smooth surfaces	Page 187
Elcometer 1620	Manual Cupping Tester - Dial Gauge, mm/mils	Page 101
Elcometer 1542	Cross Cut Set 6 x 1, 2, 3mm with ISO or ASTM Adhesive Tape	Page 217
Elcometer 215	Oven Data Logger	Page 168 - 169

### Qualicoat Kit 2

Model	Description	Product Information
Elcometer 406L	Statistical Glossmeter: 60°	Page 108
Elcometer 3095	Buchholz Hardness Tester	Page 93
Elcometer 1506	Mandrel Bend Tester with 5mm and 8mm (0.20 and 0.31") Mandrels	Page 99
Elcometer 1615	Base Unit and Tube Assembly	Page 102 - 103
Elcometer 1615	Kit B: ISO 6272/2 and BS 6496	Page 104
Elcometer 456	FNF Top Separate Digital Coating Thickness Gauge	Page 188 - 192
Elcometer 456	Standard FNF 1 Probe, 0 - 1500µm	Page 194 - 198
Elcometer 1620	Electrical Digital Cupping Tester (220 & 240V, Metric and 110V, Imperial)	Page 101
Elcometer 1542	Cross Cut Set 6 x 1, 2, 3mm with ISO or ASTM Adhesive Tape	Page 218
Elcometer 215	Oven Data Logger	Page 168 - 169

### Technical Specification

Part Number		Description
Metric Kit	Imperial Kit	
<a href="#">YKITQUALICOAT-1BM</a>	<a href="#">YKITQUALICOAT-1BE</a>	Elcometer Basic Qualicoat Powder Coatings Inspection Kit 1
<a href="#">YKITQUALICOAT-1TM</a>	<a href="#">YKITQUALICOAT-1TE</a>	Elcometer Top Qualicoat Powder Coatings Inspection Kit 2



## Elcometer HVCA Duct Inspection Kit

Controlling ducting deposits and monitoring their build-up is essential to maintain hygiene standards and reduce fire risks in heating and ventilation systems.

Both the Elcometer 355 and Elcometer 456 Duct Deposit Measuring Systems have been specifically designed to meet the requirements of the DTT (Deposit Thickness Test) in the HVCA's (Heating and Ventilation Contractors' Association) Guide to Good Practice, for the measurement of dust and grease deposits within ventilation systems and kitchen ducts made of ferrous metals.

The difference between the systems is accuracy. The Elcometer 355 Duct Deposit Measuring System is accurate to  $\pm 1\%$  or  $1\mu\text{m}$ , whichever is the greater, whilst the Elcometer 456 System is accurate to  $\pm 2.5\%$  or  $2.5\mu\text{m}$ , whichever is the greater.



### Technical Specification

Part Number	Description
<b>A456DUCT</b>	Elcometer 456 HVCA Duct Deposit Measuring Kit
<b>A355F1B</b>	Elcometer 355 Duct Deposit Measuring Kit
Measurement Range	0 - 1500 $\mu\text{m}$ (0 - 60mils)
Probe Lead Length	1.5m (5ft)
Dimensions	310 x 260 x 80mm (12.2 x 10.2 x 3.1")
Weight	1.5kg (3.3lb)
Packing List	Elcometer 456 Top Separate, Ferrous F1 duct probe, duct cleaning template, foil set (25, 50, 250 $\mu\text{m}$ with zero plate), ElcoMaster™ software, batteries, wrist harness, carry case and operating instructions
Packing List	Elcometer 355 unit, F1B duct probe, duct cleaning template, foil set (25, 50, 250 $\mu\text{m}$ with zero plate), ElcoMaster™ software, batteries, wrist harness, ear piece, PC and parallel printer cables, leather case, carry case and operating instructions

### Accessories

<b>T35513548</b>	Elcometer 355 Duct Probe Module
<b>T456F1D</b>	Elcometer 456 Probe: Ferrous F1 Duct, 0 - 1500 $\mu\text{m}$ (0 - 60mils)
<b>T99916651</b>	Window Protection Film (Pack of 50)
<b>T99916063</b>	Wrist Harness
<b>T9904905-1</b>	Precision Foil Set (25, 50 and 250 $\mu\text{m}$ with Zero Plate) and Wallet
<b>T99920130</b>	USB Bluetooth Transmitter/Receiver
<b>T99916716</b>	USB-Serial RS232 Cable

## Elcometer Automotive Inspection Kits

### Inspection Kits 1 & 2

Produced specifically for the automotive after market, including Insurance Assessors, 3rd party consultants, body shops and used car sales, these kits provide an instant measure of the coating thickness of panels. An illuminated magnifier is supplied to enable close inspection of bodywork.

A digital thermometer is supplied with Kit 2, to verify, for example, panel temperatures when welding special steels.



### Kit 1 and 2 Contents

Model	Description	Product Information
Elcometer 415	Digital Coating Thickness Gauge	Page 187
Elcometer 137	Illuminated Magnifier (x 10)	Page 258
Elcometer 214L	Digital Laser Thermometer*	Page 165

\* The Digital Laser Thermometer is supplied with Kit 2

Can be used in accordance with: (see Standards Explained inside Front Cover)

ASTM B 244, [ASTM B 499](#), ASTM D 1400, ASTM D 1186-B, [ASTM D 7091](#), BS 5411-(3) (11), BS 3900 C5, DIN 50984, DIN 50981, [ISO 2178](#), [ISO 2360](#), [ISO 2808](#)

### Technical Specification

Part Number	Description
<a href="#">YKITAUTOMOTIVE-1</a>	Elcometer Automotive Inspection Kit 1
<a href="#">YKITAUTOMOTIVE-2</a>	Elcometer Automotive Inspection Kit 2
Dimensions	310 x 260 x 80mm (12.2 x 10.2 x 3.1")
Weight	Kit 1: 1kg (2.2lb) Kit 2: 1.5kg (3.3lb)

## Elcometer 138 Bresle Salt Kit

It is essential that the level of contaminants on a surface is measured prior to application of the coating to ensure the quality of the coating and that its optimum lifetime is achieved.

If the coating is applied to a contaminated surface, which is not properly prepared, it could fail prematurely resulting in costly re-coating and high maintenance costs. The Elcometer 138 Bresle Kit includes the Elcometer 138 Conductivity Meter which accurately measures the salinity of the test samples.



### Kit Contents

T13818515	Elcometer 138 Conductivity Meter
E135----B	Bresle Patches (Box of 25)
T13818517	3 x 5ml (0.1fl oz) Syringes
T13818518	3 x Needles
T13818519	Plastic Beaker 30ml (1fl oz)
T13818516	4 x Calibration Standards Solution
T99911344	Pure Water 250ml (8.5fl oz)

### Technical Specification

Part Number	Description
E138----1	Elcometer 138 Bresle Salt Kit
Tests per Kit	25
Dimensions	300 x 220 x 75mm (11 x 8.6 x 3")
Weight	2.1kg (4.62lb)
Measuring Range	2% full scale $\pm 1$ digit. At a depth of more than 10ms/cm, the range is 3% full scale $\pm 1$ digit
Packing List	Box of 25 x Elcometer Bresle patches, 250ml pure water in clear plastic bottle, 3 x 5ml (0.1fl oz) syringes, 3 x blunt needles, 30ml (1fl oz) plastic beaker, Elcometer 138 Conductivity Meter, 2 x CR2032 lithium batteries, 2 x standard solution (1.41 mS/cm), moistening solution, purified water, pipette, conductivity meter storage pouch, carry case and operating instructions

Can be used in accordance with: (see Standards Explained inside Front Cover)

ISO 8502-6, ISO 8502-9, ISO 8502-11, AS 3894.6-A, SSPC Guide 15, US Navy NSI 009-32, US Navy PPI 63101-000

## Elcometer 138/2 Surface Contamination Kit

The Elcometer 138/2 Surface Contamination Kit provides the means for testing invisible surface contaminants:

- pH
- chloride ions
- iron
- salts



### Kit Contents

E135----A	Bresle Sampler (Box of 50)
T13818517	3 x 5ml (0.1fl oz) Syringes
T13818518	3 x Needles
T13818519	Plastic Beaker, 30ml (1fl oz)
T99911344	Pure Water, 250ml (8.5fl oz)
T13820562	100 x pH Test Strips
T13820563	100 x Iron Test Strips
T13820564	40 x Chloride Test Strips

### Technical Specification

Part Number	Description
E138----2	Elcometer 138/2 Surface Contamination Kit
Measuring Range	pH: 0pH to 14pH Iron: 3 - 10 - 25 - 50 - 100 - 250 - 500mg/l Fe <sup>2</sup> Chloride: 30µg/cm <sup>2</sup> (30ppm) Cl to 600µg/cm <sup>2</sup> (600ppm) Cl
Dimensions	300 x 220 x 75mm (11 x 8.6 x 3")
Weight	2.1kg (4.62lb)
Packing List	100 x pH test strips, 100 x Iron test strips, 40 x Chloride test strips, 50 x Bresle samplers, 3 x 5ml (0.2fl oz) syringes, 3 x needles, 30ml (1fl oz) plastic beaker, carry case and operating instructions
<i>Can be used in accordance with: (see Standards Explained inside Front Cover)</i>	
ISO 8502-6, SSPC Guide 15	

## Elcometer 134 CSN Chloride, Sulphate & Nitrate Kit

Designed to accurately, measure surface chloride, sulphate and nitrate ions in minutes, the Elcometer 134 CSN Salt kit offers a single kit solution for testing in the field.

All the components of the Elcometer CSN Test Kits are pre-measured and pre-dosed for trouble free testing.

Results are recorded in parts per million (ppm) requiring no complicated calculations. Elcometer 134 CSN tests are all designed to use a ratio of 1:1 for easy conversion to  $\mu\text{g}/\text{cm}^2$ .

Supplied in an ABS plastic carry case for easy portability around the site, each field kit is supplied with full instructions attached to the inside lid, together with:

- 5 x Chloride tests
- 5 x Sulphate tests, together with 1 x colorimeter, for sulphate testing
- 5 x Nitrate test strips
- 5 x Syringes (without needles)



### Technical Specification

Part Number	Description
<b>E134-CSN</b>	Elcometer 134 CSN Chloride, Sulphate & Nitrate Test Kit
Measuring Range	0 - 100 $\mu\text{g}/\text{cm}^2$ (0 - 100ppm)
Scale Resolution	1 $\mu\text{g}/\text{cm}^2$ (1ppm)
Sample Time	1 - 5 minutes (approximately)
Storage Temperature	Not exceeding 25°C (77°F)
Dimensions	360 x 320 x 140mm (14.2 x 12.6 x 5.5")
Weight	1.76kg (3.8lb)
Packing List	5 x tests (containing: 5 x chloride tests, 5 x nitrate test strips, 5 x sulphate tests, 5 x syringes) 1 x colorimeter, carry case and operating instructions

*Can be used in accordance with: (see Standards Explained inside Front Cover)*

**ISO 8502-5, NACE 6G186, NACE 6, SSPC SP13, SSPC Guide 15**

### Accessories

<b>T134---C</b>	1 set of 5 Nitrate Tests
<b>T134-KIT</b>	Refill Kit for Elcometer 134 CSN

## What is the correct probe for each Coating/Substrate

The list below shows common coating/substrate combinations. If you do not see your coating/substrate combination, please contact Elcometer to discuss your particular requirement.

Elcometer offers a free Test Sample Report. Contact Elcometer and arrange for our Technical Department to establish the most appropriate gauge for your process.

COATING	SUBSTRATE									
	Aluminium	Brass	Bronze	Copper	Steel	Magnesium	Stainless Steel	Titanium	Uranium	Zinc
Aluminium	-	-	-	-	F	-	-	-	-	-
Anodising	NF	-	-	-	-	NF	-	-	-	-
Brass	-	-	-	-	F	-	-	-	-	-
Bronze	-	-	-	-	F	-	-	-	-	-
Cadmium	-	-	-	-	F	-	-	-	-	-
Ceramic	-	-	-	-	F	-	-	-	-	-
Chrome (Hard)	NF*	-	-	NF*	F	-	-	-	-	-
Copper	-	-	-	-	F	-	-	-	-	-
Eloxal	NF	-	-	-	F	-	-	-	-	-
Epoxy	NF	NF	NF	NF	F	-	NF	NF	-	NF
Galvanising	-	-	-	-	F	-	-	-	-	-
Lacquer	NF	NF	NF	NF	F	-	NF	-	-	NF
Metal Spray	-	-	-	-	F	-	-	-	-	-
Molybdenum Disulphide	-	-	-	-	F	-	NF	-	-	-
Nickel (Electroless)	NF*	NF*	-	NF*	F	-	-	-	-	-
Paint	NF	NF	NF	NF	F	NF	NF	NF	NF	NF
Plastic	NF	NF	NF	NF	F	NF	NF	NF	NF	NF
Plating	-	-	-	-	F	-	-	-	-	-
Rubber	NF	-	-	-	F	-	-	-	NF	-
Resist	-	-	-	NF	-	-	-	-	-	-
Tin	-	-	-	-	F	-	-	-	-	-
Varnish	NF	NF	NF	NF	F	-	-	-	-	-
Zinc	-	-	-	-	F	-	-	-	-	-

NF: use Non-Ferrous probe

F: use Ferrous probe

\*: known sample required for calibration

## Standards Information

This section lists all Standards included in this catalogue. Current Standards are shown in orange and superseded Standards are shown in grey. For further information please see Standards Explained on the inside of the front cover.

Standard	Reference	Elcometer Model	Page	Standard	Reference	Elcometer Model	Page
<b>AS</b>				<b>ASTM</b>			
AS 1580.108.2	Dry Film Thickness	141	212	ASTM B 244	Dry Film Thickness	355 (N1, N4)	202 - 204
AS 1580.108.2	Dry Film Thickness	121/3	213	ASTM B 499	Dry Film Thickness	101	205
AS 1580.213.2	Appearance	6014	113 - 114	ASTM B 499	Dry Film Thickness	211	206
AS 1580.408.4	Adhesion	107, 1542	217 - 218	ASTM B 499	Dry Film Thickness	415	187
AS 1580.408.4	Dry Film Thickness	121/3	213	ASTM B 499	Dry Film Thickness	355 (F), 456 (F)	188 - 204
AS 2331.1.3	Dry Film Thickness	101, 211	205, 206	ASTM B 648	Hardness	3101	95
AS 2331.1.4	Dry Film Thickness	415	187	ASTM C 584	Appearance	406, 407	108 - 109
AS 2331.1.4	Dry Film Thickness	355 (F,N), 456 (FNF)	188 - 204	ASTM D 1084-B	Viscosity	2300	21 - 25
				ASTM D 1084-C	Viscosity	2200	20
AS 2331.1.7	Dry Film Thickness	195	211	ASTM D 1084-D	Viscosity	2210	12
AS 3894.1	Porosity	236	236 - 238	ASTM D 1186-A	Dry Film Thickness	211	206
AS 3894.1	Porosity	266	231 - 235	ASTM D 1186-B	Dry Film Thickness	101	205
AS 3894.2	Porosity	270	228	ASTM D 1186-B	Dry Film Thickness	415	187
AS 3894.3-A	Dry Film Thickness	211	206	ASTM D 1186-B	Dry Film Thickness	355 (F), 456 (F)	188 - 204
AS 3894.3-B	Dry Film Thickness	355 (F,N), 456 (FNF)	188 - 204	ASTM D 1186-B	Dry Film Thickness	415	187
AS 3894.4	Hardness	3101	95	ASTM D 1200	Viscosity	2351, 2435	10, 16
AS 3894.4	Hardness	501, 3080, 3086, 3092	84 - 87	ASTM D 1210	Dispersion	2020, 2041, 2050	2 - 3
AS 3894.5	Surface Profile	125	134	ASTM D 1212-A	Wet Film & Powder	3230	181, 182
AS 3894.5	Surface Profile	127	134	ASTM D 1212-B	Wet Film & Powder	3233	180
AS 3894.5	Surface Profile	129	135	ASTM D 1316	Dispersion	2070	4
AS 3894.6-A	Surface Cleanliness	135, 138	148 - 150, 153	ASTM D 1400	Dry Film Thickness	415	187
AS 3894.9	Adhesion	107, 1542	217 - 218	ASTM D 1400	Dry Film Thickness	355 (N), 456 (N)	188 - 204
AS 3894.9	Dry Film Thickness	121/3	213	ASTM D 1455	Appearance	406, 407	108 - 109
AS/NZS 1580.107.3	Wet Film & Powder	3230	181, 182	ASTM D 1475	Density	1800	30
AS/NZS 1580.107.3	Wet Film & Powder	112, 115, 3236, 3238	178 - 179	ASTM D 1653	Drying Time	5100	68
AS/NZS 1580.108.1	Dry Film Thickness	211	206	ASTM D 1655	Flash Point	6910 closed	34 - 36
AS/NZS 1580.108.1	Dry Film Thickness	415	187	ASTM D 1729	Appearance	6300	116 - 117
AS/NZS 1580.108.1	Dry Film Thickness	355 (F,N), 456 (FNF)	188 - 204	ASTM D 1737	Elasticity & Deformation	1500, 1506	99 - 100
AS/NZS 1580.204.1	Dispersion	2020, 2041, 2050	2 - 3	ASTM D 2196	Viscosity	2300	21 - 25
AS/NZS 1580.213.1	Film Application	Leneta	55 - 64	ASTM D 2200	Surface Cleanliness	128	154, 240
AS/NZS 1580.214.1	Viscosity	2200	20	ASTM D 2240	Hardness	3120	93 - 94
AS/NZS 1580.214.2	Viscosity	2354 cup 4 only	15	ASTM D 2457	Appearance	406, 407	108 - 109
AS/NZS 1580.214.5	Viscosity	2300	21 - 25	ASTM D 2486	Film Application	Leneta	55 - 64
AS/NZS 1580.402.1	Elasticity & Deformation	1500, 1506	99, 100	ASTM D 2486	Washability & Abrasion	1720 Tool 2	70 - 75
AS/NZS 1580.403.1	Hardness	3000/3	88	ASTM D 2583	Hardness	3101	95
AS/NZS 1580.405.1	Hardness	501, 3080, 3086	84 - 86	ASTM D 2745	Appearance	6014	113 - 114
AS/NZS 1580.406.1	Elasticity & Deformation	1615	102 - 106	ASTM D 2794	Elasticity & Deformation	1615	102 - 106
AS/NZS 1580.408.5	Adhesion	1910	222	ASTM D 2801	Film Application	4260, 4280	49
AS/NZS 1580.408.5	Adhesion	106	220	ASTM D 2805	Appearance	6014	113 - 114
AS/NZS 1580.408.5	Adhesion	110	226	ASTM D 2805	Film Application	Leneta	55 - 64
AS/NZS 1580.459.1	Washability & Abrasion	1720	70 - 75	ASTM D 3278	Flash Point	6910 closed	34 - 36
AS/NZS 1580.601.1	Appearance	6300	116 - 117	ASTM D 332-B	Dispersion	2000	6
AS/NZS 1580.602.2	Appearance	406, 407	108 - 109	ASTM D 3359-B	Adhesion	107, 1542	217 - 218
				ASTM D 3359-B	Dry Film Thickness	121/3	213
				ASTM D 3359-B	Hardness/Adhesion	1535	91 - 92
				ASTM D 3363	Hardness	501, 3080, 3086	84 - 86
				ASTM D 344	Film Application	Leneta	55 - 64
				ASTM D 3450	Washability & Abrasion	1720 Tool 4	70 - 75
				ASTM D 3828	Flash Point	6910 closed	34 - 36

Standard	Reference	Elcometer Model	Page	Standard	Reference	Elcometer Model	Page
ASTM D 387	Dispersion	2000	6	ASTM D 891-B	Density	1800	30
ASTM D 4039	Appearance	6012	112	ASTM D 968-A	Washability & Abrasion	1700	82
ASTM D 4138-A	Dry Film Thickness	141	212	ASTM E 2501	Porosity	260	230
ASTM D 4138-A	Dry Film Thickness	121/3	213	ASTM E 376	Dry Film Thickness	355 (F,N), 456 (FNF)	188 - 204
ASTM D 4138-C	Dry Film Thickness	195	211	ASTM E 376	Dry Film Thickness	415	187
ASTM D 4147	Film Application	4360, 4361	38 - 39	ASTM E 502	Flash Point	6910 closed	34 - 36
ASTM D 4206	Flash Point	6910 open	34 - 36	ASTM E 797	Material thickness	204, 205 - 208	126 - 130
ASTM D 4212	Viscosity	2210	12	ASTM E 96	Drying Time	5100	68
ASTM D 4212	Viscosity	2310	13	ASTM F 1319	Washability & Abrasion	1720 Tool 8	70 - 75
ASTM D 4213	Washability & Abrasion	1720 Tool 5	70 - 75	ASTM G 12	Dry Film Thickness	101	205
ASTM D 4213:92	Washability & Abrasion	1720 Tool 3	70 - 75	ASTM G 12	Dry Film Thickness	211	206
ASTM D 4366	Hardness	3030, 3040	91	ASTM G 12	Dry Film Thickness	355 (F), 456 (F)	188 - 204
ASTM D 4414-A	Wet Film & Powder	112, 115, 3236, 3238	178 - 179	ASTM G 6	Porosity	236	236 - 238
ASTM D 4417-A	Surface Profile	125	134	ASTM G 6	Porosity	266	231 - 235
ASTM D 4417-A	Surface Profile	127	134	ASTM G 6	Porosity	270	228
ASTM D 4417-B	Surface Profile	123, 223, 224	137, 141	ASTM G 62-A	Porosity	270	228
ASTM D 4417-C	Surface Profile	122, 124	136	ASTM G 62-B	Porosity	236	236 - 238
ASTM D 4488	Washability & Abrasion	1720	70 - 75	ASTM G 62-B	Porosity	266	231 - 235
ASTM D 4541	Adhesion	108	219	<b>BS</b>			
ASTM D 4541	Adhesion	110	226	BS 1344-11	Porosity	236	236 - 238
ASTM D 4541	Adhesion	1910	222	BS 1344-11	Porosity	266	231 - 235
ASTM D 4541	Adhesion	1940, 1941	223 - 224	BS 1881-207	Adhesion	106/6	221
ASTM D 4541	Adhesion	106	220	BS 1881-207	Adhesion	1940, 1941	223 - 224
ASTM D 4787	Porosity	236	236 - 238	BS 3900 A6:1971	Viscosity	2354	15
ASTM D 4787	Porosity	266	231 - 235	BS 3900-A11	Flash Point	6910 open	34 - 36
ASTM D 4828	Washability & Abrasion	1720 Tool 3	70 - 75	BS 3900-A13	Flash Point	6910 closed	34 - 36
ASTM D 5125	Viscosity	2353, 2437	11, 15	BS 3900-A14	Flash Point	6910 closed	34 - 36
ASTM D 5150	Film Application	Leneta	55 - 64	BS 3900-A7-2	Viscosity	2300	21 - 25
ASTM D 5162-A	Porosity	270	228	BS 3900-C5-3	Dry Film Thickness	126, 3240	214
ASTM D 5162-B	Porosity	236	236 - 238	BS 3900-C5-5B	Dry Film Thickness	121/3	213
ASTM D 5162-B	Porosity	266	231 - 235	BS 3900-C5-5B	Dry Film Thickness	141	212
ASTM D 522-A	Elasticity & Deformation	1510	98	BS 3900-C5-6A	Dry Film Thickness	211	206
ASTM D 522-B	Elasticity & Deformation	1500, 1506	99, 100	BS 3900-C5-6A	Dry Film Thickness	415	187
ASTM D 523	Appearance	406, 407	108 - 109	BS 3900-C5-6A	Dry Film Thickness	355 (F), 456 (F)	188 - 204
ASTM D 5420	Elasticity & Deformation	1615	102 - 106	BS 3900-C5-6A	Dry Film Thickness	355 (N), 456 (N)	188 - 204
ASTM D 562	Viscosity	2200	20	BS 3900-C5-6B	Dry Film Thickness	3230	181, 182
ASTM D 5895-B	Drying Time	5500	66	BS 3900-C5-7A	Wet Film & Powder	154	180
ASTM D 7091	Dry Film Thickness	415	187	BS 3900-C5-7B	Wet Film & Powder	112, 115, 3236, 3238	178 - 179
ASTM D 7091	Dry Film Thickness	355 (F,N), 456 (FNF)	188 - 204	BS 3900-D4	Appearance	6014	113 - 114
ASTM D 7091	Dry Film Thickness	415	187	BS 3900-E1	Elasticity & Deformation	1500, 1506	99, 100
ASTM D 7234	Adhesion	106/6	221	BS 3900-E11	Elasticity & Deformation	1510	98
ASTM D 7234	Adhesion	1940, 1941	223 - 224	BS 3900-E13	Elasticity & Deformation	1615	102 - 106
ASTM D 7378-A	Wet Film & Powder	155	183	BS 3900-E19	Hardness	501, 3080, 3086	84 - 86
ASTM D 7378-C	Wet Film & Powder	550	184	BS 3900-E2	Hardness	3000/3	88
ASTM D 823-C	Film Application	4340	52 - 54	BS 3900-E4	Elasticity & Deformation	1620	101
ASTM D 823-E	Film Application	3505, 3520, 3525, 3230, 3540, 3545, 3550, 3560, 3570, 3580, 3600, 3700, 3800	42 - 50	BS 3900-E5	Hardness	3030, 3040	91
				BS 3900-E6	Adhesion	107, 1542	217 - 218
				BS 3900-E6	Dry Film Thickness	121/3	213
				BS 3900-E9	Hardness	3095	92
				BS 5411-11	Dry Film Thickness	101	205
				BS 5411-11	Dry Film Thickness	211	206
				BS 5411-11	Dry Film Thickness	415	187
				BS 5411-11	Dry Film Thickness	355 (F), 456 (F)	188 - 204



Standard	Reference	Elcometer Model	Page	Standard	Reference	Elcometer Model	Page
BS 5411-3	Dry Film Thickness	415	187	EN 12636	Adhesion	1940, 1941	223 - 224
BS 5411-3	Dry Film Thickness	355 (N), 456 (N)	188 - 204	EN 12956	Washability & Abrasion	1720 Tools ST1, ST2, ST4	70 - 75
BS 5599	Dry Film Thickness	415	187	EN 13144	Adhesion	106	220
BS 5599	Dry Film Thickness	355 (N), 456 (N)	188 - 204	EN 13144	Adhesion	1940, 1941	223 - 224
BS 6496:1984	Elasticity & Deformation	1615	102 - 106	EN 13144	Adhesion	1910	222
BS 6664-3	Flash Point	6910 closed	34 - 36	EN 1348	Adhesion	1940, 1941	223 - 224
BS 6664-4	Flash Point	6910 closed	34 - 36	EN 13523-1	Dry Film Thickness	415	187
BS 7079-B4	Climate	319	156 - 159	EN 13523-1	Dry Film Thickness	355 (F,N), 456 (FNF)	188 - 204
BS 7079-C5	Surface Profile	122, 124	136	EN 13523-11	Washability & Abrasion	1720 Tool 9B	70 - 75
BS 7442-3.2	Hardness	3120	93	EN 13523-12	Hardness	3000/3	88
BS 7479	Hardness	1538	96	EN 13523-16	Taber	406, 407	108 - 109
BS 7793-2	Porosity	270	228	EN 13523-2	Appearance	501, 3080, 3086	84 - 86
BS 950-2	Appearance	6300	116 - 117	EN 13523-4	Hardness	1615	102 - 106
<b>DIN</b>				EN 13523-5	Elasticity & Deformation	1542	218
DIN 1048	Adhesion	106/6	221	EN 13523-6	Adhesion	107, 1542	217 - 218
DIN 1048	Adhesion	1940, 1941	223 - 224	EN 13523-6	Dry Film Thickness	121/3	213
DIN 50021	Hardness	1538	96	EN 13523-6	Elasticity & Deformation	1620	101
DIN 50981	Dry Film Thickness	211	206	EN 14430	Porosity	236	236 - 238
DIN 50981	Dry Film Thickness	355 (F), 456 (F)	188 - 204	EN 14430	Porosity	266	231 - 235
DIN 50984	Dry Film Thickness	415	187	EN 15317	Material thickness	204, 205 - 208	126 - 130
DIN 50984	Dry Film Thickness	355 (N), 456 (N)	188 - 204	EN 1542	Adhesion	1940, 1941	223 - 224
DIN 50986	Dry Film Thickness	121/3	213	EN 1542	Adhesion	106/6	221
DIN 50986	Dry Film Thickness	141	212	EN 21524	Dispersion	2020, 2041, 2050	2 - 3
DIN 53146	Appearance	6014	113 - 114	EN 22063	Hardness/Adhesion	1537	96
DIN 53152	Elasticity & Deformation	1500, 1506	99, 100	EN 233/C3.2-A	Washability & Abrasion	1720 Tool ST1	70 - 75
DIN 53153	Hardness	3095	92	EN 233/C3.2-B	Washability & Abrasion	1720 Tool ST2	70 - 75
DIN 53156	Elasticity & Deformation	1620	101	EN 233/C3.2-C	Washability & Abrasion	1720 Tool ST3	70 - 75
DIN 53157	Hardness	3030, 3040	91	EN 24624	Adhesion	106	220
DIN 53162-2	Film Application	Leneta	55 - 64	EN 24624	Adhesion	1910	222
DIN 53167	Hardness	1538	96	EN 24624	Adhesion	1940, 1941	223 - 224
DIN 53203	Dispersion	2020, 2041, 2050	2 - 3	EN 438-2	Hardness	3000	88 - 89
DIN 53211	Viscosity	2350, 2434	10, 16	EN 438-2	Hardness	3025	90
DIN 53217-2	Density	1800	30	EN 438-2	Hardness	3092	87
DIN 53224	Viscosity	2353, 2437	11, 15	EN 456	Flash Point	6910 closed	34 - 36
DIN 53232	Elasticity & Deformation	1620	101	EN 535	Viscosity	2353, 2437	11, 15
DIN 53233	Washability & Abrasion	1700	82	EN 60730-1-A	Washability & Abrasion	1720 Tool 10	70 - 75
DIN 53505	Hardness	3120	93 - 94	<b>FTMS</b>			
DIN 53778-2:1983	Washability & Abrasion	1720 Tool 1	70 - 75	FTMS 141 4121	Film Application	Leneta	55 - 64
DIN 55984	Appearance	6014	113 - 114	FTMS 141 4183	Density	1800	30
<b>ECCA</b>				FTMS 141 4184	Density	1800	30
ECCA T1	Dry Film Thickness	355 (F,N), 456 (FNF)	188 - 204	FTMS 141 4411.1	Dispersion	2020, 2041, 2050	2 - 3
ECCA T11	Washability & Abrasion	1720 Tool 9A	70 - 75	FTMS 141 4494.1	Film Application	4270, 4280, 4290	49 - 50
ECCA T12	Hardness	3000/3	88	FTMS 141 6191	Washability & Abrasion	1700	82
ECCA T4	Hardness	501, 3080, 3086	84 - 86	<b>GME</b>			
ECCA T5	Elasticity & Deformation	1615	102 - 106	GME 60269	Washability & Abrasion	1720 Tool 9	70 - 75
ECCA T6	Adhesion	107, 1542	217 - 218	<b>IMO</b>			
ECCA T6	Dry Film Thickness	121/3	213	IMO MSC.215(82)	Dry Film Thickness	355 (F), 456 (F)	188 - 204
ECCA T6	Elasticity & Deformation	1620	101	IMO MSC.215(82)	Surface Cleanliness	128	154, 240
<b>EN</b>				IMO MSC.215(82)	Surface Profile	125	134
EN 12206-1:2004	Elasticity & Deformation	1615	102 - 106	IMO MSC.215(82)	Surface Profile	123, 223, 224	137, 141
EN 12373-11	Appearance	406, 407	108 - 109				
EN 12636	Adhesion	106/6	221				

Standard	Reference	Elcometer Model	Page	Standard	Reference	Elcometer Model	Page
<b>ISO</b>							
ISO 105-X12	Washability & Abrasion	1720 Tool 8	70 - 75	ISO 2808-7D	Dry Film Thickness	355 (N), 456 (N)	188 - 204
ISO 11998	Washability & Abrasion	1720 Tool 6	70 - 75	ISO 2808-7D	Dry Film Thickness	415	187
ISO 1461	Dry Film Thickness	355 (F), 456 (F)	188 - 204	ISO 2811-1	Density	1800	30
ISO 14654	Porosity	270	228 - 229	ISO 2813	Appearance	406, 407	108 - 109
ISO 1518	Hardness	3000/3	88	ISO 2814	Appearance	6014	113 - 114
ISO 15184	Hardness	501, 3080, 3086	84 - 86	ISO 2814	Film Application	Leneta	55 - 64
ISO 1519-2	Elasticity & Deformation	1500, 1506	99, 100	ISO 2815	Hardness	3095	92
ISO 1520	Elasticity & Deformation	1620	101	ISO 2884-2	Viscosity	2300	21 - 25
ISO 1522	Hardness	3030, 3040	91	ISO 3274	Surface Profile	7060	142 - 143
ISO 1524	Dispersion	2020, 2041, 2050	2 - 3	ISO 3668	Appearance	6300	116 - 117
ISO 16276-1	Adhesion	106	220	ISO 3679	Flash Point	6910 closed	34 - 36
ISO 16276-1	Adhesion	1910	222	ISO 3680	Flash Point	6910 closed	34 - 36
ISO 16276-1	Adhesion	1940, 1941	223 - 224	ISO 4586-2	Hardness	3000	88 - 89
ISO 16276-1	Adhesion	110	226	ISO 4586-2	Hardness	3025	90
ISO 16276-1	Adhesion	108	219	ISO 4586-2	Hardness	3092	87
ISO 16276-2	Adhesion	107, 1542	217 - 218	ISO 4624	Adhesion	106	220
ISO 16276-2	Dry Film Thickness	121/3	213	ISO 4624	Adhesion	1910	222
ISO 19840	Dry Film Thickness	355 (F), 456 (F)	188 - 204	ISO 4624	Adhesion	1940, 1941	223 - 224
ISO 2063	Dry Film Thickness	355 (F), 456 (F)	188 - 204	ISO 6272:1993	Elasticity & Deformation	1615	102 - 106
ISO 2063	Hardness	1537	96	ISO 6272-1:2002	Elasticity & Deformation	1615	102 - 106
ISO 2178	Dry Film Thickness	101	205	ISO 6272-2:2002	Elasticity & Deformation	1615	102 - 106
ISO 2178	Dry Film Thickness	211	206	ISO 6504-3	Appearance	6014	113 - 114
ISO 2360	Dry Film Thickness	415	187	ISO 6860	Elasticity & Deformation	1510	98
ISO 2360	Dry Film Thickness	355 (N), 456 (N)	188 - 204	ISO 7267-2	Hardness	3120	93 - 94
ISO 2409	Adhesion	107, 1542	217 - 218	ISO 7668	Appearance	406, 407	108 - 109
ISO 2409	Dry Film Thickness	121/3	213	ISO 7783-1	Drying Time	5100	68
ISO 2431	Viscosity	2353, 2437	11, 15	ISO 7783-2	Drying Time	5100	68
ISO 2555	Viscosity	2300	21 - 25	ISO 787-16	Dispersion	2000	6
ISO 2746	Porosity	236	236 - 238	ISO 8289-A	Porosity	270	228
ISO 2746	Porosity	266	231 - 235	ISO 8501-1	Surface Cleanliness	128	154, 240
ISO 2808-12	Dry Film Thickness	415	187	ISO 8502-11	Surface Cleanliness	134 CSN	152
ISO 2808-12	Dry Film Thickness	355 (F), 456 (F)	188 - 204	ISO 8502-11	Surface Cleanliness	135, 138	148 - 150, 153
ISO 2808-12	Dry Film Thickness	355 (F,N), 456 (FNF)	188 - 204	ISO 8502-3	Surface Cleanliness	142	146
ISO 2808-12	Dry Film Thickness	355 (N), 456 (N)	188 - 204	ISO 8502-4	Climate	319	156 - 159
ISO 2808-1A	Wet Film & Powder	154	180	ISO 8502-5	Surface Cleanliness	134 CSN	152
ISO 2808-1A	Wet Film & Powder	112, 115, 3236, 3238	178 - 179	ISO 8502-5	Surface Cleanliness	134S	147
ISO 2808-1B	Wet Film & Powder	3230	181, 182	ISO 8502-6	Surface Cleanliness	135, 138	148 - 150, 153
ISO 2808-3	Dry Film Thickness	126, 3240	214	ISO 8502-9	Surface Cleanliness	135, 138	148 - 150, 153
ISO 2808-4B	Dry Film Thickness	126, 3240	214	ISO 8503-1	Surface Profile	125	134
ISO 2808-5B	Dry Film Thickness	141	212	ISO 8503-2	Surface Profile	125	134
ISO 2808-5B	Dry Film Thickness	121/3	213	ISO 8503-5	Surface Profile	122, 124	136
ISO 2808-6A	Dry Film Thickness	415	187	ISO 868	Hardness	3120	93 - 94
ISO 2808-6A	Dry Film Thickness	355 (F), 456 (F)	188 - 204	ISO 8780-5	Dispersion	2000	6
ISO 2808-6A	Dry Film Thickness	355 (F), 456 (F)	188 - 204	ISO 8780-5	Dispersion	2000	6
ISO 2808-6A	Dry Film Thickness	355 (F), 456 (F)	188 - 204	ISO 9038	Flash Point	6910 open	34 - 36
ISO 2808-6B	Dry Film Thickness	141	212	ISO 9227	Hardness	1537	96
ISO 2808-6B	Dry Film Thickness	121/3	213				
ISO 2808-6B	Dry Film Thickness	415	187	<b>JIS</b>			
ISO 2808-7A	Dry Film Thickness	211	206	JIS A 1452	Washability & Abrasion	1700	82
ISO 2808-7B	Wet Film & Powder	112, 115, 3236, 3238	178 - 179	JIS G 3491	Porosity	236	236 - 238
ISO 2808-7C	Dry Film Thickness	415	187	JIS G 3491	Porosity	266	231 - 235
ISO 2808-7C	Dry Film Thickness	355 (F), 456 (F)	188 - 204	JIS G 3492	Porosity	236	236 - 238
				JIS G 3492	Porosity	266	231 - 235
				JIS K 5600-5-	Elasticity & Deformation	1615	102 - 106
				JIS Z 8741	Appearance	406, 407	108 - 109

Standard	Reference	Elcometer Model	Page	Standard	Reference	Elcometer Model	Page
<b>NACE</b>				<b>SAE</b>			
NACE RP0188	Porosity	236	236 - 238	SAE J361	Appearance	6300	116 - 117
NACE RP0188	Porosity	266	231 - 235	<b>SANS</b>			
NACE RP0188	Porosity	270	228 - 229	SANS 5772	Surface Profile	123, 223, 224	137, 141
NACE RP0190	Porosity	266	231 - 235	<b>SS</b>			
NACE RP0274	Porosity	236	236 - 238	SS 184159	Dry Film Thickness	355 (N)	188 - 204
NACE RP0274	Porosity	266	231 - 235	SS 55900	Surface Cleanliness	128	154, 240
NACE RP0287	Surface Profile	122, 124	136	<b>SSPC</b>			
NACE RP0490	Porosity	236	236 - 238	SSPC Guide 15	Surface Cleanliness	130	151
NACE RP0490	Porosity	266	231 - 235	SSPC Guide 15	Surface Cleanliness	134 CSN	152
NACE SP0188	Porosity	236	236 - 238	SSPC Guide 15	Surface Cleanliness	134S	147
NACE SP0188	Porosity	266	231 - 235	SSPC Guide 15	Surface Cleanliness	135, 138	148 - 150, 153
NACE SP0188	Porosity	270	228 - 229	SSPC PA2	Dry Film Thickness	101	205
NACE TM0384	Porosity	270	228 - 229	SSPC PA2	Dry Film Thickness	211	206
<b>NBN</b>				SSPC PA2	Dry Film Thickness	355 (F), 456 (F)	188 - 204
NBN T22-104	Elasticity & Deformation	1620	101	SSPC VIS 1	Surface Cleanliness	128	154, 240
NBN T22-105	Hardness	3030, 3040	91	SSPC VIS 2	Surface Cleanliness	128	154, 240
NBN T22-108	Viscosity	2353, 2437	11, 15	SSPC VIS 3	Surface Cleanliness	128	154, 240
NBN T22-110	Density	1800	30	<b>TAPPI</b>			
<b>NF</b>				TAPPI T 515	Appearance	6300	116 - 117
NF A91-124	Hardness/Adhesion	1537	96	TAPPI T 653	Appearance	406, 407	108 - 109
NF T30-014	Viscosity	2352, 2436	11, 16	<b>US NAVY</b>			
NF T30-016	Hardness	3030, 3040	91	US Navy NSI 009-32	Climate	319	156 - 159
NF T30-017:1989	Elasticity & Deformation	1615	102 - 106	US Navy NSI 009-32	Dry Film Thickness	355 (F,N)	188 - 204
NF T30-018	Drying Time	5100	68	US Navy NSI 009-32	Surface Cleanliness	128	154, 240
NF T30-019	Elasticity & Deformation	1620	101	US Navy NSI 009-32	Surface Cleanliness	135, 138	148 - 150, 153
NF T30-020	Density	1800	30	US Navy NSI 009-32	Surface Profile	122, 124	136
NF T30-038	Adhesion	107, 1542	217 - 218	US Navy NSI 009-32	Surface Profile	123, 223, 224	137, 141
NF T30-040	Elasticity & Deformation	1500, 1506	99, 100	US Navy NSI 009-32	Wet Film & Powder	112, 115, 3236, 3238	178 - 179
NF T30-052	Hardness	3095	92	US Navy PPI 63101-000	Climate	319	156 - 159
NF T30-062	Adhesion	1940, 1941	223 - 224	US Navy PPI 63101-000	Dry Film Thickness	355 (F,N), 456 (FNF)	188 - 204
NF T30-070	Viscosity	2353, 2437	11, 15	US Navy PPI 63101-000	Surface Cleanliness	128	154, 240
NF T30-122	Dry Film Thickness	126, 3240	214	US Navy PPI 63101-000	Surface Cleanliness	135, 138	148 - 150, 153
NF T30-124	Dry Film Thickness	415	187	US Navy PPI 63101-000	Surface Profile	122, 124	136
NF T30-124	Dry Film Thickness	355 (F), 456 (F)	188 - 204	US Navy PPI 63101-000	Wet Film & Powder	112, 115, 3236, 3238	178 - 179
NF T30-125	Wet Film & Powder	154	180	<b>NORSOK</b>			
NF T30-125	Wet Film & Powder	3230	181, 182	NORSOK M-501	Adhesion	109	221
NF T30-125	Wet Film & Powder	3233	180	<b>PSA</b>			
NF T30-125	Wet Film & Powder	112, 115, 3236, 3238	178 - 179	PSA D45 1010	Washability & Abrasion	1720 Tool 8	70 - 75
NF T30-227	Dispersion	2000	6				
NF T30-606	Adhesion	106	220				
NF T30-606	Adhesion	108	219				
NF T30-606	Adhesion	109	221				
NF T30-606	Adhesion	1940, 1941	223 - 224				
NF T31-210-5	Dispersion	2000	6				
NF T34-721-2	Drying Time	5100	68				
NF T38-501	Hardness	3101	95				
NF T51-109	Hardness	3120	93 - 94				

Product Type	Page	Product Type	
4 Sided Film Applicator	49		
<b>A</b>			
Abrading Wheels and Wearasers	78		
Abrasers	76 - 78		
Abrasion	76 - 82		
Abrasion - Accessories	79 - 80		
Abrasion - Car Wash	81		
Abrasion - Linear	76		
Abrasion - Rotary	77 - 80		
Accessories & Publications	239 - 246		
<b>Adhesion</b>	<b>216 - 226</b>		
Adhesion - Cross Hatch Method	216 - 218		
Adhesion - Hydraulic	219, 222 - 225		
Adhesion - Non Destructive	221		
Adhesion - Pneumatic	226		
Adhesion - Pull Off Method	220		
Adhesion - Push Off Method	219		
Adhesion Tester - Digital	219		
Adjustable Baker Film Applicator	41		
Adjustable Blade Applicators	45 - 46		
Adjustable Draw Down Applicators	42 - 47		
AFNOR Viscosity Dip Cups	11		
AFNOR Viscosity Flow Cups	16		
Air Probes - Climate	171 - 172		
Air Thermometers	160		
Aluminium Wet Film Combs	179		
Analytical Balance	32		
<b>Appearance</b>	<b>107 - 124</b>		
Appearance - Colour	115 - 124		
Appearance - Gloss	108 - 111		
Appearance - Haze	112		
Appearance - Shade & Opacity	113 - 114		
Appendix A	258		
Applicators - 4 sided	49		
Applicators - Adjustable	41, 43		
Applicators - Baker Film	40 - 41		
Applicators - Bird	42 - 43		
Applicators - Casting Knife	44		
Applicators - Cube	47		
Applicators - Doctor Blade	45 - 46, 48		
Applicators - Reservoir	46 - 47		
ASTM Viscosity Dip Cups	10		
ASTM Viscosity Flow Cups	16		
Atlas of Coating Defects	243		
Automatic Film Applicators	52 - 54		
Automotive Inspection Kit	254		
Automotive Refinishing Gauge	186		
<b>B</b>			
Baker Film Applicator	40		
Balances	31 - 32		
Banana Type' Coating Thickness Gauge	206		
Bar Coaters - Spiral	38 - 39		
Bar Coaters - Spiral	95		
Barcol Hardness Tester	95		
Bend Testers	98 - 99		
Bird Film Applicator	42 - 43		
Black & White Test Charts	61		
Black Light - see Ultra Violet	230		
Bluetooth Coating Thickness Gauge	188 - 193		
Bluetooth Surface Profile Gauge	137 - 139		
Bresle Patches	150		
Bresle Salt Kit	149, 255		
Bresle Sampler	150		
Brushout Cards	57		
Brushability Tester	70 - 74		
Brushes - Abrasion	73 - 74		
BS Viscosity Flow Cups	15		
Buchholz Hardness Tester	92		
<b>C</b>			
Calculator - Dewpoint	160		
Calculator - Galvanising	246		
Calibration Foils	208 - 209		
Calibration Oils - Rotational Viscosity	25		
Calibration Oils - Viscosity Cups	18		
Car Wash Simulator	81		
Casting Knife Film Applicator	44		
Channelled Vacuum Tables	51		
Charts - Leneta	55 - 64		
Checkerboard Charts	59, 62 - 63		
Chloride Ion Test Kit for Abrasives	146		
Chloride Ion Test Kit for Surfaces	147		
Chloride Ion Test Kit for Water/Liquids	147		
Chloride, Sulphate, Nitrate Test Kit - CSN	152, 257		
Circular Drying Time Recorder	66		
Clemen Scratch Tester - Manual	88 - 89		
Clemen Scratch Tester - Motorised	88 - 89		
Clemen Unit - Hardness	88 - 89		
<b>Climate</b>	<b>155 - 176</b>		
Climate Condition Testing	156 - 176		
Closed Cup Tester - Flash Point	34		
Coated Standards	210		
Coating Defects Atlas	243		
Coating Inspection Kits	247 - 258		
Coating Inspection Software	200 - 201		

Product Type	Page	Product Type	Page
Coating Thickness - Bluetooth	188 - 193	<b>Deformation</b>	<b>97 - 106</b>
Coating Thickness - Calibration Foils	207 - 209	Densimeters	30
Coating Thickness - Coated Standards	210	<b>Density</b>	<b>29 - 32</b>
Coating Thickness - Marker Pens	241	Density Cup	30
Coating Thickness - Säberg Drill	211	Destructive Coating Thickness Gauge	211 - 213
Coating Thickness - Test Plates	207	Dewpoint Calculator	160
Coating Thickness Gauge - Accessories	199, 204	Dewpoint Meter	156 - 159
Coating Thickness Gauge - Destructive	211 - 213	Differential Mode - see Ultrasonics	130
Coating Thickness Gauge - Digital	186 - 204	Digital Adhesion Tester	219
Coating Thickness Gauge - Mechanical	205 - 206	Digital Coating Thickness - Accessories	199, 204
Coating Thickness Gauge - PIG	212 - 213	Digital Coating Thickness Gauges	186 - 204
Coating Thickness Gauge - Pull Off	205	Digital Moisture Meter	176
Coating Thickness Gauge - 'Tooke' Type	212 - 213	Digital Pocket Thermometers	162
Coating Thickness - Zero Plates	207	Digital Rotational Viscometer	21 - 25
Coil Coating Wet Film Thickness	182	Digital Surface Profile Gauge	137 - 139, 141
Colour	115 - 124	Digital Thermometer	162 - 166
Colour Assessment Cabinets	116 - 117	Digital Waterproof Thermometers	163
Colour Charts - RAL	115	DIN Scratching Tool	96
Colour Meter	107 - 124	DIN Viscosity Dip Cups	10
Colour Spectrophotometer	118 - 124	DIN Viscosity Flow Cups	15
Combs - Powder	183	Dip Cup Stands	14
Combs - Wet Film	178 - 180	Dip Cups	10 - 13
Compact "A" Moisture Meter	175	Dip Cups - Viscosity	10 - 13
Compact "B" Moisture Meter	175	<b>Dispersion</b>	<b>1 - 7</b>
Compact Moisture Meter	174	<b>Dispersion - Paint mixers</b>	<b>7</b>
Comparators - Surface	134 - 135	Display Charts	58, 60
Concrete Adhesion Tester	221	Disposable' Wet Film Combs	180
Concrete Moisture Meter	176	Doctor Blade Film Applicator	45
Conductivity Meter	148 - 149	Doctor Blade Film Applicator with Reservoir	46
Conductivity Meter - Salt	148 - 149	Draw Down Applicators	42 - 47
Conical Mandrel Bend Tester	98	Draw Down Bars	41 - 43, 45
Corrosion Scratch	96	Draw Down Charts	56 - 61
Corrosion Scratch Tool - DIN	96	Dry & Wet Film Gauges	214
Corrosion Scratch Tool - ISO	96	<b>Dry Film Thickness</b>	<b>185 - 214</b>
Cross Cut - Adhesion	216 - 218	Dry Film Thickness - Bluetooth	188 - 193
Cross Hatch - Adhesion	216 - 218	Dry Film Thickness - Destructive	211 - 213
CSN Chloride, Sulphate & Nitrate Test Kit	152, 257	Dry Film Thickness - Digital	186 - 202
Cube Film Applicator	47	Dry Film Thickness - Mechanical	205 - 206
Cup - Density	30	Dry Film Thickness - Probes	194 - 198, 203
Cup - Viscosity	10 - 17	<b>Drying Time</b>	<b>65 - 68</b>
Cupping Tester - Manual	101	Drying Time Recorders - Circular	66
Cupping Tester - Motorised	101	Drying Time Recorders - Linear	67
Curing Time Recorder	67	Duplex Applicator Charts	57
Cylindrical Mandrel Bend Tester	99	Durometer - Shore	93 - 94
Cylindrical Mandrels on a Stand	100	Dust Tape Test Kit	146
<b>D</b>		<b>E</b>	
Daniel Flow Gauge	28	Echo-to-Echo Mode - see Ultrasonic	125
DC Holiday Detector	231 - 238	<b>Elasticity</b>	<b>97 - 106</b>

Product Type	Page	Product Type	Page
Elasticity & Resistance Deformation	97 - 106		
ElcoMaster™ Data Management Software	140, 258, 200 - 201		
Electronic Coating Thickness Gauge	186 - 204		
Electronic Thermo-hygrograph	167		
<b>F</b>		<b>G</b>	
Falling Sand Tester	82	Galvanising Calculator	246
Film Application	<b>38 - 64</b>	Gloss	107 - 111
Film Applicator - Adjustable Baker	41	Gloss Measurement	107 - 111
Film Applicator - Adjustable Bird	43	Gloss Meters	107 - 111
Film Applicator - Automatic	52 - 54	Grey Scale Charts	62
Film Applicator - Baker	40 - 41	Grindometers	3 - 4, 6
Film Applicator - Bird	42 - 43	Groove Depth Checker - Fineness of Grind	5
Film Applicator - Casting Knife	44	<b>H</b>	
Film Applicator - Cube	47	<b>Hardness</b>	<b>83 - 96</b>
Film Applicator - Micrometric	43	Hardness - Barcol	95
Film Applicator - Motorised	52 - 54	Hardness - Indentation Method	93 - 95
Film Applicator - Multiple Gap	47	Hardness - Pencils	84 - 86
Film Applicator - Quadruplex	50	Hardness - Shore	93 - 94
Film Applicator - Spiral Bar Coaters	38 - 39	Hardness - Wolff Wilborne	84
Film Thickness Gauge - see Coating Thickness	185	Hardness Tester - König	91
Fineness of Grind - Groove Depth Checker	5	Hardness Tester - Persoz	91
Fineness of Grind Gauge - North Gauge	2	Hardness Tester - Persoz / König	91
Fineness of Grind Gauge - NPIRI	4	Hardness Tester - Sclerometer	87
Fineness of Grind Gauge - NS Hegman Gauge	2	Haze	107, 112
Fineness of Grind Gauge - Precision	3	Haze Meter	112
Fineness of Grind Gauges	2 - 4	Hegman Gauge - see Fineness of Grind	2
Fitz's Atlas of Coating Defects	243	Hexagonal Wet Film Comb	179
Flash Light	241	Hexagonal Wet Film Thickness	179
Flash Light - Ultra Violet	230	Hiding Power Charts	62
<b>Flash Point</b>	<b>33 - 36</b>	Hiding Power Meter - Opacity Meter	113
Flexibility Testers - Bend Testers	98 - 99	High Precision Grindometer	3
Flexibility Testers - Cupping Testers	101	High Temperature Probe	194 - 195
Flexibility Testers - Impact Testers	102 - 106	High Voltage Porosity Testers	231 - 238
Flow Cups	15 - 16	Holiday Detectors	231 - 238
Flow Cups - Viscosity	15 - 16	HVAC Duct Inspection Kit	253
Flow Gauge	28	Hydraulic Adhesion Tester	219, 222 - 225
Fluidity Meter	28	Hygrometer - Whirling & Sling	160
Fluorescent UV Pinhole Flashlight	230	<b>I</b>	
Foil Gauge	136	Ideal Finish Oven Profile Software	170 - 171
Foils	208 - 209	Illuminated Inspection Mirrors	242
FORD/ASTM Viscosity Dip Cups	10	Illuminated Magnifiers	244
FORD/ASTM Viscosity Flow Cups	16	Illuminated Microscope	245
Freestanding Vacuum Tables	51	IMO Inspection Kit	248
Frikmar Dip Viscosity Cups - AFNOR	11	Impact Testers	102 - 106
Frikmar Dip Viscosity Cups - DIN	10	Infrared Digital Thermometer	165 - 166
Frikmar Dip Viscosity Cups - FORD/ASTM	10	Infrared Thermometers	165 - 166
Frikmar Dip Viscosity Cups - ISO	11	<b>Inspection Kits</b>	<b>247 - 258</b>
Frikmar Cups	10 - 11	Inspection Kit - Automotive	254
Frikmar Cups - Viscosity	10 - 11	Inspection Kit - HVAC Duct	253
		Inspection Kit - Marine	248
		Inspection Kit - Powder Coating	251
		Inspection Kit - Protective Coating	249 - 250

Product Type	Page	Product Type	Page
Inspection Kit - Qualicoat Powder	252	Multiple Film Doctor Blade Applicators	50
Inspection Mirrors	242	Multiple Gap Film Applicator	47
Inspection Test Kits	247 - 258	<b>N</b>	
Interface-to-Echo Mode - see Ultrasonics	130	Needle Probe	162 - 164
International Standard Reference Numbers	259	Newtonian Fluids	9, 19
ISO 8502-3 Dust Tape Kit	146	Nitrate Test Kit	152, 257
ISO Groove Depth Checker	5	Non-Contact Uncured Powder Gauge	184
ISO Scratching Tool	96	Non-Newtonian Fluids	9, 19
ISO Viscosity Dip Cups	11	North Gauge - see Fineness of Grind	2
ISO Viscosity Flow Cups	15	Novo-Curve™ Glossmeter for Curved Surfaces	111
<b>J</b>		Novo-Haze™ Haze Meter	112
Jeep' Tester - see High Voltage Porosity	231 - 235	Novo-Soft™ Software	110
<b>K</b>		NPIRI Gauge - see Fineness of Grind	4
KB Balance	31	NS Gauge - see Fineness of Grind	2
Keane-Tator Surface Comparators & Magnifier	134	NYPC Levelling Tester	49
König Hardness Tester - Pendulum	91	NYPC Levelling & Sag Tester	50
Krebs Digital Viscometer	20	<b>O</b>	
<b>L</b>		Oils - Rotational Viscosity	25
Laboratory Grinder - Muller	6	Oils - Viscosity Cups	18
Leneta Test Charts	55 - 64	Opacity Charts	56
Levelling Tester - NYPC	49	Opacity-Display Charts	60
Levelling & Sag Tester - NYPC	50	Opacity Meter	113
Light Cabinets	116 - 11	Open Cup Tester - Flash Point	35
Linear Abraser - Taber®	76	Oven Data Logger	<b>168 - 172</b>
Linear Drying Time Recorder	67	Oven Data Recorder	168 - 172
Liquid Thermometers	162 - 164	Oven Loggers	168 - 172
Long Edge Wet Film Comb	178	Oven Profile	168 - 172
Lory LCH Viscosity Cups	14	<b>P</b>	
<b>M</b>		Paint & Powder Gauge	187
Macaw's Pipeline Defects	243	Paint Inspection Gauge	212 - 213
Magnetic Surface Thermometer	161	Paint Mixers	7
Magnetic Thermometers	161	Paint Safe Marker Pens	241
Marine Inspection Kit	248	PAT™ Adhesion Tester	223 - 225
Marker Pens	241	PATHandy™ Adhesion Tester	222
<b>Material Thickness</b>	<b>125 - 132</b>	PATTI Adhesion Tester	226
Matthis Fluidometer	28	Payne Permeability Cup	68
Mechanical Coating Thickness Gauge	205 - 206	PCU Gauge - see Fineness of Grind	2
Meier Gauge	68	Pencil Hardness Pencils	86
Micrometric Film Applicator	43	Pencil Hardness Tester	84
Microscope	244 - 245	Pencil Hardness Tester - Motorised	85
Microscope with Reticules	245	Pendulum Hardness Tester - Konig	91
Minimix Paint Meter	7	Pendulum Hardness Tester - Persoz	91
Mirrors	242	Pendulum Hardness Tester - Persoz / Konig	91
Mixers - Paint Mixer	7	Penopac Charts	56
Moisture Meters	173 - 176	Perforated Vacuum Tables	51
Motorised Pencil Hardness	85	Permeability Cup - Payne	68
Motorised/Automatic Film Applicator	52 - 54	Pendulum Hardness Tester	91
Muller Laboratory Grinder	6	Persoz Hardness Tester - Pendulum	91

Product Type	Page	Product Type	Page
Persoz/Konig Hardness Tester - Pendulum	91	Rotational Viscosity	19 - 25
Pfund Wet Film Thickness Gauge	180	Rotational Viscosity Calibration Oils	25
Picnometers - Density	30	Roughness Comparator	134 - 135
Pictorial Surface Standards	154, 240	Roughness Tester - Inductive Method	136
PIG - Paint Inspection Gauge	212 - 213	Roughness Tester - SURFTEST	142 - 143
Pinhole & Porosity Detectors	227 - 238	Rubert Surface Comparator	135
Pinhole Detectors	228 - 229	Rugotest Surface Comparators	135
Pipe Pit Gauge	144	<b>S</b>	
PLAS Mode - see Ultrasonics	130	Säberg Drill Coating Thickness Gauge	211
Plastic Wet Film Combs	180	Safety Torch / Flash Light	241
Pneumatic Adhesion Testers	226	Sag & Levelling Tester	50
Pocket Microscope	244	Sag Quadruplex Film Applicator	50
<b>Porosity</b>	<b>227 - 238</b>	Sag Tester	49
Porosity - High Voltage Method	231 - 238	Salt Conductivity Meter	148 - 149
Porosity - Low Voltage Method	228 - 229	Salt Contamination Meter	151
Porosity - Purple Light (UV) Method	230	Scales - see Balances	31 - 32
Porosity - Ultra Violet Method	230	Scan Mode - see Ultrasonics	130
Portable Sphere Spectrophotometers	118 - 123	Sclerometer Hardness Tester	87
Powder Coating Inspection Kit	251	Scratch / Shear Tester	90
Powder Thickness	183 - 184	Scratch Tester - Sclerometer	87
Powder Thickness - Cured	183	Scratch Tester - Taber®	90
Powder Thickness - Uncured	184	Scrub Test Panels	64
Powder Thickness Comb	183	Setaflash 'Series 3' Active Cool	36
Precision Fineness of Grind Gauge	3	Setaflash 'Series 3' Closed Cup Tester	34
Precision Foils	209	Setaflash 'Series 3' Open Cup Tester	35
Precision Ultrasonic Gauges	126 - 127	Shade & Opacity Meter	113 - 114
Precision Ultrasonic Thickness Gauges	126 - 127	Shell Viscosity Cups	13
Precision Ultrasonic Transducers	127	Ship's Propeller Comparators	135
Precision Vacuum Tables	51	Shore Durometer	93 - 94
Probe Adaptors	199, 204	Shore Impressor Hardness Testers	93 - 94
Probe Placement Jig	199, 204	Sling Hygrometer	160
Profileometer - see Surface Roughness	142 - 143	Sling Psychrometers	160
Protective Coating Inspection Kit	249 - 250	Software - Appearance	110
Psychrometers - Sling	160	Software - Coating Inspection	200 - 201
Pull Off Adhesion Tester	220	Software - Colour	124
Punch Aluminium Wet Film Thickness	179	Software - Oven Temperature Recording	170 - 171
Purple Light (UV) Porosity	230	Software - Surface Profile	140
Push Off Adhesion Tester	219	Software - Viscosity	26 - 27
<b>Q</b>		Spark Testers	228 - 229, 231 - 238
Quadruplex Film Applicator	50	Specific Gravity Cup	30
Qualicoat	168 - 171, 252, 258	Spectrophotometer	118 - 124
Qualicoat Powder Inspection Kit	252	Speed of Sound Through Materials	127
<b>R</b>		Spiral Bar Coaters	38 - 39
RAL Colour Charts	115	Spongeability Tester	75
Reflectometer - Shade Meter	113	Spray Monitors - see Leneta	63
Relative Humidity Gauge	156 - 159	Spray Strips - see Leneta	62
Replic Tape - Testex®	136	Spreading Rate Charts	58 - 60
RH Meter - see Dewpoint Meter	156 - 159	Statistical Mini Glossmeter	108
Rotary Abraser - Taber®	77 - 80	Steel Ultrasonic Thickness Gauges	128



Product Type	Page	Product Type	Page
Sulphate Test Kit	152, 257	Universal Paint Inspection Gauge	213
Surefire® Fluorescencator UV Pinhole Flashlight	230	Unlacquered Test Charts	55 - 63
<b>Surface Cleanliness</b>	<b>145 - 154</b>	Unsealed Test Charts	56 - 63
Surface Comparator - Keane-Tator	134	Unvarnished Test Charts	61
Surface Comparator - Rubert	135	<b>V</b>	
Surface Comparator - Rugotest	135	Vacuum Tables	51
Surface Comparator - Ship's Propellor	135	Vacuum Tables - Channelled	51
Surface Comparators	134 - 135	Vacuum Tables - Perforated	51
Surface Contamination Kit	153, 256	Vacuum Tables - Precision	51
Surface Moisture Meter	173	Variable Impact Tester	102 - 106
Surface Probe - Climate	163 - 164	<b>Viscosity</b>	<b>8 - 28</b>
<b>Surface Profile</b>	<b>133 - 144</b>	Viscosity - Accessories	17 -18, 24 - 25
Surface Profile Comparator	134 - 135	Viscosity - AFNOR Cups	11, 16
Surface Profile Gauge	137 - 141	Viscosity - BS Cups	15
Surface Roughness Comparator	134 - 135	Viscosity - Cup Calibration Oils	18
Surface Standards - Pictorial	154, 240	Viscosity - DIN Cups	10, 16
Surface Standards - Visual	154, 240	Viscosity - Dip Cup Stand	14
Surface Thermometers	161	Viscosity - Flow Cups	15 - 16
SURFTEST SJ-201P Roughness Tester	142	Viscosity - Flow Cups - AFNOR	16
SURFTEST SJ-301 Roughness Tester	143	Viscosity - Flow Cups - BS	15
<b>T</b>		Viscosity - Flow Cups - DIN	16
Taber® Abrading Wheels	78	Viscosity - Flow Cups - FORD/ASTM	16
Taber® Abrasion	76 - 80	Viscosity - Flow Cups - ISO	15
Taber® Linear Abraser	76	Viscosity - FORD/ASTM Cups	10, 16
Taber® Rotary Abraser	77 - 80	Viscosity - Frikmar Dip Cups	10 - 11
Taber® Scratch / Shear Tester	90	Viscosity - Frikmar Dip Cups - AFNOR	11
Taber® Wearasers	78	Viscosity - Frikmar Dip Cups - DIN	10
Tensile Adhesion	221	Viscosity - Frikmar Dip Cups - FORD/ASTM	10
Test Charts	55 - 64	Viscosity - Frikmar Dip Cups - ISO	11
Test Charts - Unlacquered	55 - 63	Viscosity - ISO Cups	11, 15
Test Charts - Unsealed	56 - 63	Viscosity - Lory Cup	14
Test Charts - Unvarnished	61	Viscosity - Rotational Calibration Oils	25
Test Plates	207	Viscosity - Rotational Viscosity	19 - 25
Testex® Replica Tape	136	Viscosity - Rotational Viscosity - Krebs	20
Thermo-hygrograph	167	Viscosity - Shell Cups	13
Thermometers - Air	165	Viscosity - ViscosityMaster™ Software	26 - 27
Thermometers - Liquid	162 - 164	Viscosity - Zahn Cups	12
Thermometers - Magnetic	161	Viscosity Conversion Disc	17
Thermometers - Surface	161, 166	Viscosity Cup Accessories	17 - 18
Thickness Gauge	136	Viscosity Cup Conversion Chart	8
Thickness Standards	210	Viscosity Cup Stand	14
Transducers - Ultrasonic	127, 131 - 132	ViscosityMaster™ Software	26 - 27
Triple Angle Statistical Glossmeter	109	<b>W</b>	
<b>U</b>		<b>Washability</b>	<b>69 - 82</b>
Ultrasonic Thickness Gauges	126 - 130	Washability and Abrasion Testers	70 - 74
Ultrasonic Thickness Gauges - Precision	126 - 127	Waterproof Probe	196
Ultrasonic Thickness Transducers	127, 131 - 132	Wearasers - Taber®	78
Uncured Powder Film Comb	183	<b>Wet Film &amp; Powder Thickness</b>	<b>177 - 184</b>



## The Divisions of Elcometer

Elcometer has a range of test equipment for:

- **Coatings Inspection**  
A comprehensive range of test equipment from the laboratory to the field.
- **Concrete Inspection**  
Rebar locators, covermeters, half-cell measurement, etc.
- **Industrial Metal Detection**  
Box locators, metal detectors, wall tie locators, etc.
- **Cable Location**  
Live cable location, cable avoidance tools, pipe location, etc.

For more information please contact Elcometer.



© Elcometer Limited, 2008  
SLI0031 - Issue 1

Elcometer is a registered trademark of Elcometer Limited  
ElcoMaster™ & ViscosityMaster™ are trademarks of Elcometer Limited.  
Novo-Shade™, Novo-Haze™, Novo-Curve™ & Novo-Soft™ are the trademarks of Rhopoint Instruments Ltd.  
X-Rite & X-RiteColor are the registered trademarks of X-Rite Corp. All other trademarks are acknowledged.

All rights reserved. No part of this document may be reproduced, transmitted, stored (in a retrieval system or otherwise), or translated into any language, in any form, or by any means, without the prior written permission of Elcometer Limited. Due to our policy of continuous improvement, Elcometer Limited reserves the right to change specifications without notice.

## Contact Us

### ENGLAND

Elcometer Ltd  
Edge Lane  
Manchester M43 6BU  
Tel: +44 (0)161 371 6000  
Fax: +44 (0)161 371 6010  
e-mail: [sales@elcometer.com](mailto:sales@elcometer.com)  
[www.elcometer.com](http://www.elcometer.com)

### USA

Elcometer Inc  
1893 Rochester Industrial Drive  
Rochester Hills Michigan 48309  
Tel: +1 248 650 0500  
Toll Free: 800 521 0635  
Fax: +1 248 650 0501  
e-mail: [inc@elcometer.com](mailto:inc@elcometer.com)  
[www.elcometer.com](http://www.elcometer.com)

### CANADA

Elcometer Ltd  
PO Box 622, 401 Ouelette Avenue  
Windsor, Ontario N9A 6N4  
Tel: +1 248 650 0500  
Toll Free: 800 521 0635  
Fax: +1 248 650 0501  
e-mail: [ca\\_info@elcometer.com](mailto:ca_info@elcometer.com)  
[www.elcometer.com](http://www.elcometer.com)

### ASIA & THE FAR EAST

Elcometer (Asia) Pte Ltd  
896 Dunearn Rd  
Sime Darby Centre #3-09  
Singapore 589472,  
Republic of Singapore  
Tel: +65 6462 2822  
Fax: +65 6462 2860  
e-mail: [asia@elcometer.com](mailto:asia@elcometer.com)  
[www.elcometer.com](http://www.elcometer.com)

### BELGIUM

Elcometer SA  
Rue Vallée 13  
B-4681 Hermalle /s Argenteau  
Tel: +32 (0)4 379 96 10  
Fax: +32 (0)4 374 06 03  
e-mail: [be\\_info@elcometer.be](mailto:be_info@elcometer.be)  
[www.elcometer.be](http://www.elcometer.be)

### FRANCE

Elcometer Sarl  
97 Route de Chécy  
45430 BOU  
Tel: +33 (0)2 38 86 33 44  
Fax: +33 (0)2 38 91 37 66  
e-mail: [fr\\_info@elcometer.fr](mailto:fr_info@elcometer.fr)  
[www.elcometer.fr](http://www.elcometer.fr)

### GERMANY

Elcometer Instruments GmbH  
Ulmer Strasse 68  
73431 Aalen  
Germany  
Tel: +49(0)7361 52806 0  
Fax: +49(0)7361 52806 77  
e-mail: [de\\_info@elcometer.de](mailto:de_info@elcometer.de)  
[www.elcometer.de](http://www.elcometer.de)

For the contact details of your local distributor please see the back cover, or visit [www.elcometer.com](http://www.elcometer.com)

elcometer®  
[www.elcometer.com](http://www.elcometer.com)

