

HV-6, 8, 10, 12, 14, 16

### Special Accessories (Details on page 2)

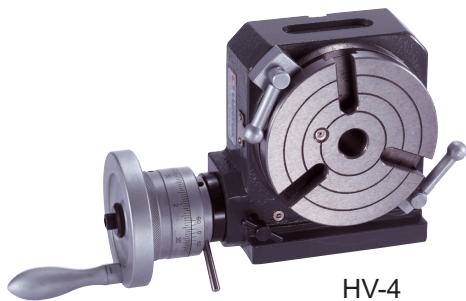

HV-4

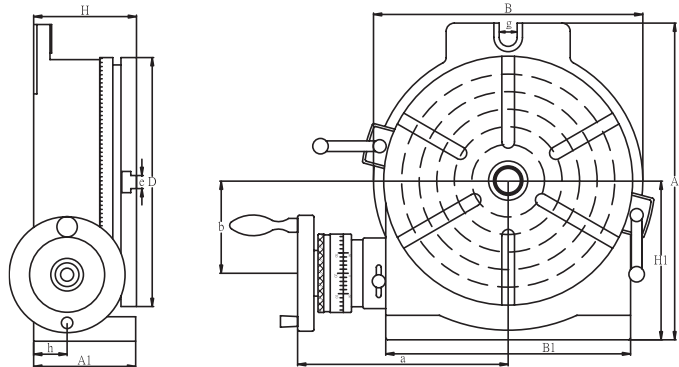

## Specifications

Unit:mm/inches

ORDER NO.	Table			Base dimension			Width of T-slot		Bolt slots g	The Load Capacity For Rotary Table		Center sleeve	Gross Weight kg wooden case(W) Carton(C)	Meas. CFT	CODE NO.
	Outer diameter	Height	H	H1	A	B	e	Type		Horizontal	Vertical				
HV-4	58	110	72	79	138	118	11	⊕	12	35 KGS	18 KGS	MT-2	(C) 7.6kgs	0.3	1001-000
HV-6	74 2.91	150 5.91	80 3.11	102 4.02	205 8.07	167 6.57	11 0.43	⊕	17 0.67	40 KGS	20 KGS	MT-2	(C) 12.7kgs	0.4	1001-001
HV-8	100 3.94	200 7.87	105 4.13	135 5.31	265 10.43	220 8.66	14 0.55	⊕	17 0.67	80 KGS	40 KGS	MT-3	(C) 26.9kgs	0.8	1001-002
HV-10	110 4.33	250 9.84	115 4.53	165 6.50	325 12.80	280 11.02	14 0.55	⊗	17 0.67	90 KGS	50 KGS	MT-3	(C) 37.7kgs	2	1001-003
HV-12	130 5.12	300 11.81	135 5.32	195 7.68	388 15.27	330 12.99	16 0.63	⊗	18 0.71	120 KGS	60 KGS	MT-4	(C) 60.6kgs	2.6	1001-004
HV-14	130 5.12	350 13.78	140 5.51	230 9.06	450 17.72	380 14.95	16 0.63	⊗	18 0.71	130 KGS	70 KGS	MT-4	(C) 79.5kgs	3.2	1001-005
HV-16	150 5.90	406 15.98	155 6.10	255 10.03	500 16.69	430 16.93	16 0.63	⊗	18 0.71	140 KGS	70 KGS	MT-4	(W) 118.4kgs	4.2	1001-006

- Our Tables are made of high density Meehanite and use "HEIDENHAIN" electronic equipment to inspect angle to assure the excellent quality and durability.
- Use excellent machining center to process. Spindle end be applied accuracy bearing. Can be assured to keep very steady under load cutting.
- Worm is hardened and ground. The ratio is 90:1. The work table is graduated a full 360° so that one turn of the handle moves the table through 4°. Micro collar is graduated in steps of 1' min. And vernier scale makes settings down to 10 seconds possible.
- These Rotary Tables are popular for their excellent performance, practical design and reasonable cost. They are widely used for circular cutting work, angle setting, boring, spot-facing and similar work.

## Test Report

ITEM NO.	TESTING OBJECTIVE	VARIATION (INCHES)(MM) MAXIMUM TESTED
1	FLATNESS OF CLAMPING SURFACE (CONCAVE)	.0006(0.015)
2	PARALLELISM OF CLAMPING SURFACE TO BASE	.0008(0.02)
3	SQUARENESS OF CLAMPING SURFACE TO ANGLE FACE	.0008(0.02)
4	TRUE RUNNING OF CLAMPING SURFACE	.0006(0.015)
5	TRUE RUNNING OF CENTER HOLE MEASURED AT HOLE EDGE	.0008(0.02)
6	INDEXING ACCURACY OF DIRECT INDEXING MECHANISM MAXIMUM CUMULATIVE SPACING ERROR	45"