



VRA-TYPE

- Used on Vertical Milling Machine to make horizontal work.
- Rigidity constructed suitable for horizontal cutting.
- The clamping bushing to suit milling machine.
- Maximum spindle speed allowed right angle. 2000 R.P.M.

※ Please notify the quill dia. when ordering

ORDER NO.	SUITABLE MILLING HEAD QUILL DIAMETER	WEIGHT (kgs)	CODE NO.
VRA-R8	85.725mm~86mm	12.5	1008-001
VRA-NT 30	85.725mm~86mm	13	1008-002
VRA-NT 40	85.725, 100, 105, 110, 115mm	18	1008-003

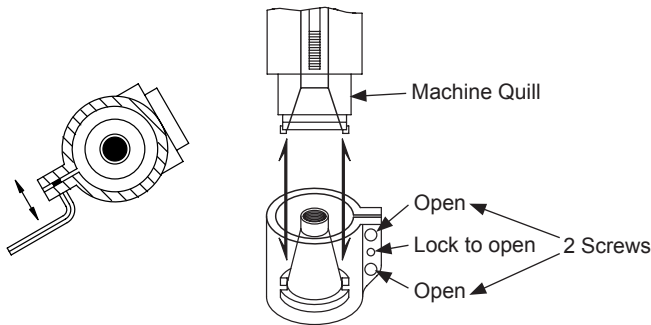

- Loose 2 screws to match with machine.
- Tighten 2 screws to fix on quill D.
- Assemble with milling quill dia.

ARBOR FOR CUTTER INCH OF MERTIC SIZE

VRA-R8	R8-SCA1"	R8-SCB22
VRA-NT 30	NT30-SCA1"	NT30-SCB27
VRA-NT 40	NT40-SCA1"	NT40-SCB27

Horizontal Milling Attachment

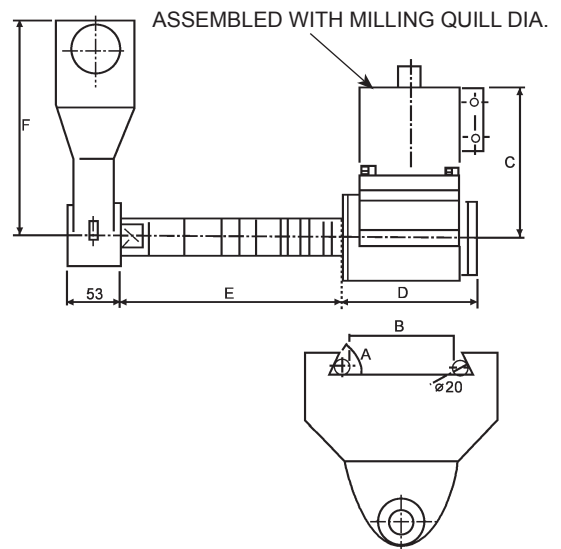
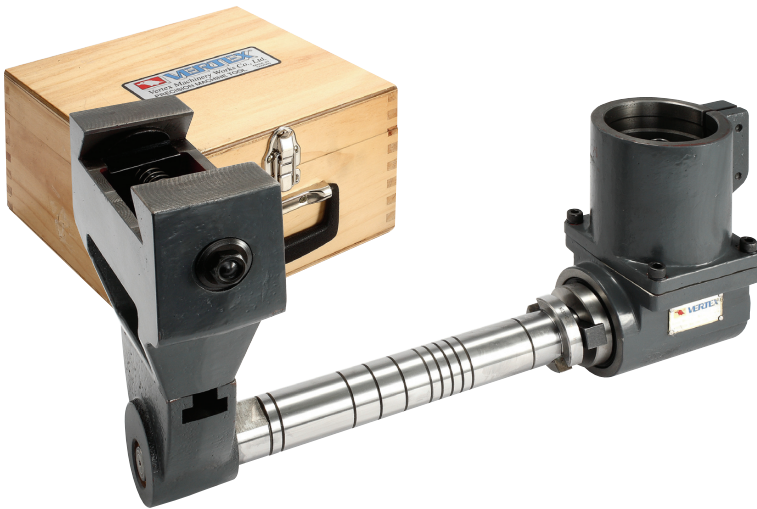

- Special dovetail degree, also can supply.....please notify.
- VHA-TYPE including right angle head, long horizontal arbor and breaker. VHA-R-8-27mm VHA-NT-30/NT-40-27mm for The mm size, for inch size are same 25.4mm (1")
- The quill diameter is same as VRA-Type
- Maximum spindle speed allowed right angle. 2000 R.P.M.

- Benefit: convert your vertical mill to a horizontal mill. Designed to simplify right angle work by reducing the need for special tooling and complex fixtures, gains your efficiency, save your time and money.

Horizontal Milling Arbor Support

TYPE	SPEC.	SUITABLE M/C RAM DOVETAIL WIDTH	WEIGHT(kgs)
A 50°	B	140mm~170mm	25.7
A 55°	B	140mm~170mm	26.5
A 60°	B	140mm~170mm	30.8

Unit:mm

ORDER NO.	C	D	E	F	CODE NO.
VHA-R-8	175	138	255	233	1008-010
VHA-NT-30	175	160	270	233	1008-011
VHA-NT-40	183	190	270	233	1008-012